



2021



# www.vignal-group.com



Photos à 360°  
Foto a 360°  
Fotos 360°



Fiches produits détaillées  
Schede prodotto dettagliate  
Fichas de producto detalladas



Centre de téléchargement  
Centro download  
Centro de descargas

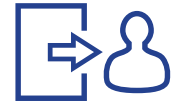

Aide questions produits  
Domande sui prodotti  
Ayuda productos



PRODUITS D'ORIGINE CONSTRUCTEURS  
 PRODOTTI ORIGINALI PRIMO IMPIANTO COSTRUTTORI  
 PRODUCTOS ORIGINALES PRIMER EQUIPO CONSTRUCTORES

ASCA.....	8
BENALU.....	12
BOBCAT.....	14
CASE.....	16
CATERPILLAR.....	17
CHEREAU.....	19
CLAAS.....	22
DAF.....	23
DE BUF.....	28
DOOSAN.....	30
FELDBINDER.....	32
FIAT.....	34
FRUEHAUF.....	35
GUILLEN.....	37
HEULIEZ.....	39
HYUNDAI CONSTRUCTION EQUIPMENT.....	41
IVECO.....	43
IVECO BUS.....	54
KUBOTA.....	60
LAMBERET.....	61
LECAPITAINE.....	65
LECIÑENA.....	66
LINDE.....	68
MAGYAR.....	69
MAN.....	70
MANITOU.....	73
MANITOWOC.....	75
MERCEDES.....	76
MERLO.....	79
NEW HOLLAND.....	80
NISSAN.....	81
OMEPS.....	82
OPEL.....	84
PEUGEOT CITROËN.....	85
RENAULT TRUCKS.....	86
SAME.....	114
SCANIA.....	115
SCHMITZ.....	117
SOR IBERICA.....	119
STEYR.....	121
STILL.....	122
TROUILLET.....	123
UD TRUCKS.....	124
VF VENIERI.....	125
VOLKSWAGEN.....	126
VOLVO.....	127
VOLVO CONSTRUCTION BUS.....	136

### **SIGNALISATION - SEGNALAZIONE - SEÑALIZACIÓN**

Feux arriere - Fanali posteriori - Pilotos traseros.....	137
Eclaireurs de plaque - Luce targa - Iluminación de placa .....	178
Feux clignotants - Luci intermittenti - Pilotos intermitentes .....	182
Feux de position - Luci di posizione - Pilotos de posición .....	189
Feux de gabarits - Luci d'ingombro - Luces de anchura.....	206
Signalisation passive - Segnaletica passiva - Señalización.....	213

### **ECLAIRAGE - ILLUMINAZIONE - ILUMINACIÓN**

Phares de recul - Fari retromarcia - Faros marcha atrás .....	218
Phares de travail - Fari da lavoro - Faros de trabajo .....	221
Éclairage de sécurité - Luci di segnalazione - Faros de advertancia.....	238
Phares de conduite - Proiettori - Proyectores .....	240
Feux auxiliaire - Fari ausiliari - Iluminación auxiliar.....	245
Éclairage intérieur - Illuminazione interna - Iluminación interior .....	248

### **Produits de sécurité - Prodotti di sicurezza - Productos de seguridad**

Gyrophares - Girofari - Luces rotativas.....	251
Rampes lumineuses - Barre di segnalazione - Puentes luminosos .....	264
Triflash.....	268
Feux de pénétration - Luci direzionali - Luces direccionales .....	271
Alarmes sonores de recul - Cicalino di retromarcia - Alarmas sonoras de marcha atrás .....	273
Systèmes caméras - Telecamere - Sistemas de cámara.....	275
Coffres porte extincteur - Cassonetti porta estintore - Porta extintores .....	291

### **ÉLECTRIQUE-ÉLECTRONIQUE - ELETTRICO-ELETTRONICO - ELÉCTRICOS-ELECTRÓNICOS**

Prises et câbles spiralés - Spine e spirali - Enchufes y espirales .....	293
Connecteurs - Connettori - Conectores .....	299
Faisceaux - Cablaggi - Cableados.....	304
Systèmes câblage et feux - Kit cablaggi e fanali - Sistemas cableados e iluminación.....	313

### **RECHERCHE PRODUITS - RICERCA PRODOTTI - BÚSQUEDA PRODUCTOS**

Par liste de correspondance - Per codice costruttore- Por referencias cruzadas.....	319
Par référence - Per riferimento - Por referencia.....	323
Par no. d'homologation - Per no. di omologazione - Por no. de homologación.....	327
Par photo - Per foto - Por foto.....	328

## Vignal Group, le spécialiste de l'éclairage et de la sécurité pour véhicules industriels et commerciaux.

Vignal Group, lo specialista in illuminazione e sicurezza per veicoli industriali e commerciali.

Vignal Group, el especialista en iluminación y seguridad para vehículos industriales y comerciales.



Un savoir faire unique  
Un know-how unico  
Un saber-hacer único



Des produits de qualité  
Prodotti di qualità  
Productos de calidad



Des années d'expertise  
Anni di esperienza  
Años de experiencia

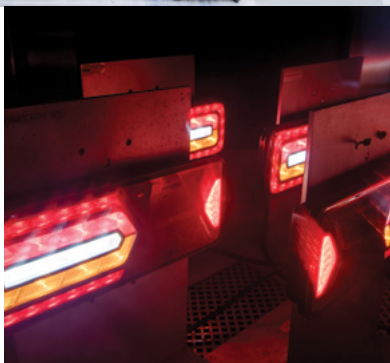

# Des marques validées par les constructeurs.

Marchi convalidati dai OE.

Marcas aprobadas OE.



Notre philosophie est de concevoir globalement et de produire localement. Nos 5 sites sont présents sur trois continents pour vous offrir la meilleure flexibilité pour le meilleur service possible.

La nostra filosofia è quella di avere un design globale per una produzione locale. Nostri 5 stabilimenti sono situati su tre continenti per offrirvi maggiore flessibilità per un servizio migliore.

Nuestra filosofía es diseñar globalmente y producir localmente. Nuestros 5 sitios están presentes en tres continentes para ofrecerle la mejor flexibilidad y servicio posibles.



## Vignal a fait du développement durable l'un de ses axes stratégiques majeurs.

Vignal ha fatto dello sviluppo sostenibile uno dei suoi principali assi strategici.

Vignal ha hecho del desarrollo sostenible uno de sus principales ejes estratégicos.



# SECTEURS SETTORI SECTORES



# Produits d'origine constructeurs

## Prodotti originali costruttori

### Productos originales constructores



**K** Catadioptré  
Catarifrangente  
Catadióptrico

**T** Catadioptré triangulaire  
Triangolo carifrangente  
Catadióptrico triangular

**FPL** Feu de position latéral  
Luce di posizione laterale  
Piloto de posición lateral

**EPP** Eclairer de plaque  
Luce targa  
Iluminación de placa

**🔊** Alarme sonore de recul  
Cicalino di ritromarcia  
Alarma sonora de marcha atrás

**🔌** Connecteurs additionnels  
Connettori addizionali  
Conectores adicionales

**AMP 1.5-7P-M**



08/2020 ->



p. 154

Type connecteur - Nb pins - Mâle ou Femelle  
Tipo di connettore - Num pin - Maschio o Femmina  
Tipo de conector - Num pines - macho o hembra

Flashez le QR code pour plus d'infos  
Scansiona il codice QR per maggiori informazioni  
Escanee el código QR para obtener más info

Pièces détachées  
Componenti  
Componentes

Dates d'application  
Date di applicazione  
Fechas de aplicación

Numéro page produit standard  
Numero di pagina del prodotto standard  
Número de página producto estándar



Faisceau p. 299  
Cablaggio p. 299  
Cableado p. 299

DETAIL CONNECTEUR 1.5	Support des Pinces des Connetteurs Pinza, alfiler	FUNCTION FUNZIONE
1	WASSE STOP	
2	POSITION TARJA	
3	REDA LATERAL	
4	INDICATEUR DE DIRECTION INDICADOR	
5	STOP	
6	MODULARE	
7	NOT USED	

Pinning connecteurs sur notre site web  
Pinning dei connettori sul nostro sito web  
Pinning conectores en nuestro sitio web



## LC12T LED

 p. 138

**LED**

 24V



**161000**

gauche - sinistra - izquierda



**AMP 1.5-7P-M**

arrière  
connettore posteriore  
conector trasero



**161010**

droit - destra - derecha



**D11868**

**AMP 1.5-7P-F**

## LC8T

 p. 157



**156040**

gauche - sinistra - izquierda



**AMP 1.5-7P-M**

arrière  
connettore posteriore  
conector trasero



**156050**

droit - destra - derecha



**156060**

gauche - sinistra - izquierda



**D11868**

**AMP 1.5-7P-F**



**056700**

gauche - sinistra - izquierda



**056710**

droit - destra - derecha



LC5TDX ⓘ p.165



**153660**

gauche - sinistra - izquierda



**AMP 1.5-7P-M**  
arrière  
connettore posteriore  
conector trasero



**153670**

droit - destra - derecha



**D11868**

**AMP 1.5-7P-F**



**053700**

gauche - sinistra - izquierda

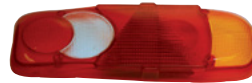

**053710**

droit - destra - derecha



LC5T ⓘ p.164

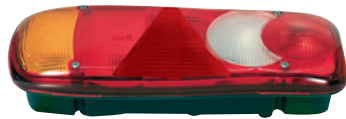

**153000**

gauche - sinistra - izquierda



**AMP 1.5-7P-M**  
arrière  
connettore posteriore  
conector trasero



**153010**

droit - destra - derecha



**153020**

gauche - sinistra - izquierda



**D11868**

**AMP 1.5-7P-F**



**053700**

gauche - sinistra - izquierda



**053710**

droit - destra - derecha



EPP96 ⓘ p.181



**D10502**

410 mm

**CLICK-IN**

## EPP96 LED

 p. 180

**LED**

 24V



**D13609** 400 mm  
**CLICK-IN**

## FE04

 p. 190

**LED**

 24V



**104310** 5000 mm



**D10132** 200 mm

## SMD98

 p. 191

**LED**

 24V



**D11399** 1500 mm **K**  
**CLICK-IN**



**001716**

## SMD04

 p. 196

**LED**

 24V



**104140** 1500 mm **K**  
**CLICK-IN**



**104100** 1500 mm **K**  
**CLICK-IN**



**104260** 1500 mm **K**  
**CLICK-IN**



**104220** 1500 mm **K**  
**CLICK-IN**

**DXLC8** ⓘ p. 158



**D13034**  
gauche - sinistra - izquierda **CLICK-IN**



**D13035**  
droit - destra - derecha **CLICK-IN**

**DX** ⓘ p. 209



**D12428** W5W  
1400 mm **CLICK-IN**

**FA3LED** ⓘ p. 207

**LED**  
12/24V



**D14427** 1500 mm  
gauche - sinistra - izquierda **CLICK-IN**



**D14428** 1500 mm  
droit - destra - derecha **CLICK-IN**

**MDJ** ⓘ p. 145



**175020**

# BENALU

## LC12 LED p. 138

**LED**

 24V



**161000**

gauche - sinistra - izquierda



**AMP 1.5-7P-M**  
arrière  
connettore posteriore  
conector trasero



**161010**

droit - destra - derecha



## LC8T p. 157



**156040**

gauche - sinistra - izquierda



**AMP 1.5-7P-M**  
arrière  
connettore posteriore  
conector trasero



**156050**

droit - destra - derecha



**D11868**

**AMP 1.5-7P-F**



**056700**

gauche - sinistra - izquierda



**056710**

droit - destra - derecha



**001830**



## SMD04 p. 196

**LED**

 24V



**104140**

1500 mm



**CLICK-IN**



**104090**

500 mm



**104100**

1500 mm



**CLICK-IN**



**104260**

1500 mm



**CLICK-IN**



**104640**

300 mm



**104650**

1000 mm



bride rallongée - supporto esteso - soporte extendido

**CLICK-IN**

## SMD98 p.191

**LED**

 24V



**D11399** 1500 mm

**CLICK-IN**



**001716**

## DXLC8 p.158



**D12712**

gauche - sinistra - izquierda

**POS-2P-F**



**D12711**

droit - destra - derecha

**POS-2P-F**

## ASR p.274

 12/24V

Multi-Frequency



**D13810**

1500 mm

97 dB



**CLICK-IN**

Standard



**630120**

87 dB



## MDJ p.145



**175020**

### LC12 LED



p. 138

LED



12V



**D161140**  
(OE 7322387)

gauche - sinistra - izquierda



AMP 1.5-7P-M

arrière  
connettore posteriore  
conector trasero



**D161150**  
(OE 7322388)

droit - destra - derecha



**D11868** AMP 1.5-7P-F

### CHL 1 LED



p. 242

LED



12V



**D14324**  
(OE 7348957)

gauche - sinistra - izquierda



DT-6P-M

arrière  
connettore posteriore  
conector trasero



**D14325**  
(OE 7348958)

droit - destra - derecha



**D14352** DT-6P-F

### RL 1500



p. 225

LED



12/24V



1500 Lumen



**D14854**  
(OE 7387145)

DT-2P-M



**D14170** DT-2P-F

## TELESCOPIC

### GALAXY LED

 p. 255

LED

 12/24V



**D14488**  
(OE 7322390)



**D14513**

## TL470, MF9000

### LC5

 p. 161



**152150**  
(OE 7164111)  
gauche - sinistra - izquierda



PG  
arrière  
connettore posteriore  
conector trasero



**152150**  
(OE 7164110)  
droit - destra - derecha



**052500**  
(OE 7027476)  
gauche - sinistra - izquierda



**052500**  
(OE 7027476)  
droit - destra - derecha



**R12931** - 1200 mm  
(OE 7028786)

DT-6P-M



**R12934** - 600 mm  
(OE 7028787)

DT-6P-M

## EPP98

 p. 181



**196010**  
(OE 7175124)

JPT-2P-M



**D13876**

JPT-2P-F



## LPL18

 p. 179

**LED**

 12/24V

08/2020 ->

**NEW**



**199000**  
(OE 47363002)

**SS-2P-M**



**D13880**

**SS-2P-F**

## SMD98

 p.197

**LED**

 12V

08/2018->



**198810**  
(OE 5141966)

**SS-2P-M**



**D13880**

**SS-2P-F**

## SH3

 p. 236

 H3/70W  
12V

08/2018 ->



**D14156**

**DT-2P-M**



**D14170**

**DT-2P-F**

## FT

 p. 234

**LED**

 12/24V

07/2017 ->



**D14191**  
(OE 47826594)



**D14192**

## SL 1000 p.222

LED

 12/24V

 1000 Lumen



**D14850**

DT-2P-M



**D14170**

DT-2P-F

## SL 1500 p.223

LED

 12/24V

 1500 Lumen



**D14851**

DT-2P-M



**D14170**

DT-2P-F

## SLA 2000 p.223

LED

 12/24V

 2000 Lumen



**D14852**

DT-2P-M



**D14170**

DT-2P-F

## RL 1000 p.225

LED

 12/24V

 1000 Lumen



**D14853**

DT-2P-M



**D14170**

DT-2P-F

## RL 1500 p.225

**LED**

 12/24V

 1500 Lumen



**D14854**

**DT-2P-M**



**D14170**

**DT-2P-F**

## RLA 2000 p.225

**LED**

 12/24V

 2000 Lumen



**D14855**

**DT-2P-M**



**D14170**

**DT-2P-F**

## SH3 p.236

 H3/70W  
24V



**D14156**

**DT-2P-M**



**D14170**

**DT-2P-F**

## RH3 p.236

 H3/70W  
24V



**D14654**

**DT-2P-M**



**D14170**

**DT-2P-F**

## BL15-CTL15

 p. 145

LED

 24V



Exemple de montage - Esempio di montaggio - Ejemplo de montaje



DT04-4P-M



**164000**  
(OE 21153)



DT04-4P-M

DTM04-4P-M



**164010**  
(OE 21154)

Pour raccordement sur feu BL15  
Per collegamento su fanale BL15  
Para conectar sobre piloto BL15



**165020**  
(OE 21781)

gauche - sinistra - izquierda



DT04-4P-M



DTM06-4S-4P-F



**165030**  
(OE 21155)

droit - destra - derecha



**D14436** DT06-4S-4P-F



**D14437** DTM06-4S-4P-F



**D14435** DTM04-4P-M

## LC12 LED

 p. 138

LED

 24V

**NEW**



**161000**

gauche - sinistra - izquierda



AMP 1.5-7P-M  
arrière  
connettore posteriore  
conector trasero

**NEW**



**161010**

droit - destra - derecha



**D11868** AMP 1.5-7P-F

## LC8T

 p. 157



**156040**

gauche - sinistra - izquierda



**AMP 1.5-7P-M**

arrière  
connettore posteriore  
conector trasero



**156050**

droit - destra - derecha



**156060**

gauche - sinistra - izquierda



**156070**

droit - destra - derecha



**D11868**

**AMP 1.5-7P-F**



**056700**

gauche - sinistra - izquierda



**056710**

droit - destra - derecha



## LC8

 p. 154



**156550**

gauche - sinistra - izquierda



**AMP 1.5-7P-M**

arrière  
connettore posteriore  
conector trasero

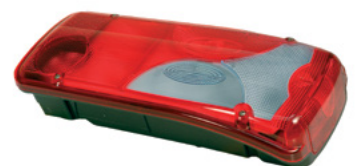

**156540**

droit - destra - derecha



**D11868**

**AMP 1.5-7P-F**

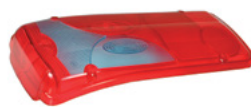

**056000**

gauche - sinistra - izquierda



**056010**

droit - destra - derecha



**001846**

## LC5T p. 164



**153020**

gauche - sinistra - izquierda



AMP 1.5-7P-M

arrière  
connettore posteriore  
conector trasero



**153010**

droit - destra - derecha



**D11868**

AMP 1.5-7P-F



**053700**

gauche - sinistra - izquierda

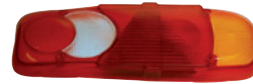

**053710**

droit - destra - derecha



## EPP96 p. 181



**196020**

R10W

## SL 1000 p. 219

LED

 12/24V

 R23



**D14857**

DT-2P-M

Feu homologué recul - Luce di retromarcia omologati  
- Piloto marcha atrás homologado



**D14170**

DT-2P-F

09/2019 ->

**NEW**



9/32V





**212400**  
(OE 27108471)



**196020**  
(OE 7700027564)

04/2012 ->



**155100**  
(OE 1875577)     
gauche - sinistra - izquierda



**HDSCS-8P-M**  
latéral  
connettere laterale  
conector lateral



**155110**  
(OE 1875576)    
droit - destra - derecha





Entraxe : 160 mm  
Distanza tra le viti posteriori : 160 mm  
Distancia entre tornillos : 160 mm



**155120**  
(OE 1875578)     
droit - destra - derecha

04/2012 ->



**155130**  
(OE 1875580)     
gauche - sinistra - izquierda



**HDSCS-8P-M**  
arrière  
connettere posteriore  
conector trasero



**155140**  
(OE 1875579)    
droit - destra - derecha



**155150**  
(OE 1875581)     
droit - destra - derecha



**D13878** **HDSCS-8P-F**



**055020**  
(OE 1914690)   
gauche - sinistra - izquierda



**055030**  
(OE 1914691)   
droit - destra - derecha



**001830**  
(OE 1973239)   
Alarme sonore de recul  
Cicalino di retromarcia  
Alarma sonora de marcha atrás



1995 -> 04/ 2012



1995 ->2001



**167640**  
(OE 1284211)  

**168020**  
(OE 1304789)   

gauche - sinistra - izquierda



DAF  
arrière  
connettore posteriore  
conector trasero



**167630**  
(OE 1284212) 

**168010**  
(OE 1304788)  

droit - destra - derecha



**168890**  
(OE 1660967)   

droit - destra - derecha

2001 -> 04/2012



**169160**  
(OE 1625985)   

gauche - sinistra - izquierda



**AMP 1.5-7P-M**  
latéral  
connettore laterale  
conector lateral



**169170**  
(OE 1625986)  

droit - destra - derecha



**169380**  
(OE 1660968)   

droit - destra - derecha



**D11868** **AMP 1.5-7P-F**



**067500**  
(OE 1272653) 

gauche - sinistra - izquierda



**067500**  
(OE 1272653) 

droit - destra - derecha



**D12953**  
(OE 1519358) 

Alarme sonore de recul  
Cicalino di retromarcia  
Alarma sonora de marcha atrás

1993 ->



**109010**  
(OE 1814096/1815754)

## CF/XF

### ICDL10

 p. 186

01/2013 ->



**117000**  
(OE 1846491)

gauche - sinistra - izquierda



**117010**  
(OE 1846492)

droit - destra - derecha



**001619**

## 75 - 85 - XF - CF

### FPL93

 p. 200



**193020**  
(OE 1329718)

**K**

JPT-2P-M



**193200**  
(OE 1653605)

**K**

JPT-2P-M



**001726**  
(OE 1608352)



**D13876**

JPT-2P-F

## LF

### LC5

 p. 161

2001 ->



**152170**  
(OE 1401713)

**K**

**EPP**

gauche - sinistra - izquierda



AMP 1.5-7P-M

arrière  
connettore posteriore  
conector trasero



**152180**  
(OE 1401731)

**K**

droit - destra - derecha



**D11868** AMP 1.5-7P-F



**052500**  
(OE 1451482)

**K**

gauche - sinistra - izquierda



**052500**  
(OE 1451482)

**K**

droit - destra - derecha

### FE95

 p. 193



**195010**  
(OE 1403887)

gauche - sinistra - izquierda



**195010**  
(OE 1403887)

droit - destra - derecha

### ICDL94

 p. 187



**119550**  
(OE 1626101)

**JPT-3P-M**



**001616**  
(OE 1626102)



**D13877** **JPT-3P-F**

### FE02

 p. 193



**102200**  
Clippé - fissaggio con clip -  
fijación con clip

**JPT-2P-M**

**K**



**001726**  
(OE 1608352)



**D13876** **JPT-2P-F**

### FPL93

 p. 200



**193020**  
(OE 1329718)

**JPT-2P-M**

**K**



**001726**  
(OE 1608352)



**D13876** **JPT-2P-F**

### EPP98

 p. 181



**196010**  
(OE 0867930)

**JPT-2P-M**



**D13876** **JPT-2P-F**

## 65 - 75 - 85 - 95

### LC4

 p. 171

-> 1993

\* Silent blocs non fournis, voir réf. 001706 p. 170

\* Silent blocs non inclusi, vedi rif. 001706 p. 170

\* Silent blocs no incluidos, ver ref. 001706 p. 170



**141500**  
(OE 2922224)  

gauche - sinistra - izquierda



PE  
arrière  
connettore posteriore  
conector trasero



**141500**  
(OE 2922224)  

droit - destra - derecha



**040500**  
(OE 0698603) 

gauche - sinistra - izquierda



**040500**  
(OE 0698603) 



droit - destra - derecha

### LC7

 p. 166

1993 -> 1995





**168100**  
(OE 1626319/1284213)   

gauche - sinistra - izquierda



DIN  
arrière  
connettore posteriore  
conector trasero



**168390**  
(OE 1626320/1284214)   

droit - destra - derecha



**067500**  
(OE 1272653) 

gauche - sinistra - izquierda



**067500**  
(OE 1272653) 

droit - destra - derecha

# DE BUF

## LC12 LED p. 138

LED

 24V



**161000**

gauche - sinistra - izquierda



AMP 1.5-7P-M  
arrière  
connettore posteriore  
conector trasero



**161010**

droit - destra - derecha



**D11868** AMP 1.5-7P-F

## SMD04 p. 196

LED

 24V



**104140**

1500 mm



CLICK-IN



**104100**

1500 mm



CLICK-IN

## FA3 LED p. 207

LED

 12/24V



**D14425**

gauche - sinistra - izquierda

SS-2P-F



**D14426**

droit - destra - derecha

SS-2P-F

## SL 1000 p. 219

LED

 12/24V

 R23



**D14857**

DT-2P-M

Feu homologué recul - Luce di retromarcia omologati  
- Piloto marcha atrás homologado



**D14170**

DT-2P-F

## SHD 1200

 p. 227

LED

 12/24V



**D14161**

DT-2P-M



**D14170**

DT-2P-F

## ATLAS

 p. 252

LED

 12/24V



**212420**



**D14513**

## EPP96 LED

 p. 180

LED

 24V



**R14364**

2000 mm

SS-2P-F

## CHL 1 H4

 p. 243

 24V  
H4 - PY21 - W5W



**D14322**  
gauche - sinistra - izquierda



**DT-6P-M**  
arrière  
connettore posteriore  
conector trasero



**D14323**  
droit - destra - derecha



**D14352** **DT-6P-F**

## SL 1500

 p. 223

**LED**

 12/24V

 1500 Lumen



**D14971** **DT-2P-M**



**D14170** **DT-2P-F**

## SLA 2000

 p. 223

**LED**

 12/24V

 2000 Lumen



**D14852** **DT-2P-M**



**D14170** **DT-2P-F**

## RH3

 p. 236

 H3/55W  
12V



**D14654** **DT-2P-M**



**D14170** **DT-2P-F**

## SH3

 p. 236

 H3/70W  
12V



**D14156**

**DT-2P-M**



**D14170**

**DT-2P-F**

## QH3

 p. 236

 H3/70W  
12V



**D14159**

**DT-2P-M**



**D14170**

**DT-2P-F**



# FELDBINDER

## LC12 LED p. 138

**LED**  
24V



**161000**

gauche - sinistra - izquierda



AMP 1.5-7P-M

arrière  
connettore posteriore  
conector trasero



**161010**

droit - destra - derecha



**D11868**

AMP 1.5-7P-F

## LC8T p. 157



**156250**

gauche - sinistra - izquierda



AMP 1.5-7P-M

arrière  
connettore posteriore  
conector trasero



**156260**

droit - destra - derecha



**D11868**

AMP 1.5-7P-F



**056720**

gauche - sinistra - izquierda



**056730**

droit - destra - derecha



## SMD04 p. 196

**LED**  
24V



**104140**

1500 mm 

CLICK-IN



**104260**

1500 mm 

CLICK-IN

## SMD98

 p.197

LED

 24V



**D10500** 500 mm 

**D11399** 1500 mm 

CLICK-IN



**D10497** 500 mm 

CLICK-IN

## FA3 LED p. 207

LED

 12/24V



**D14425**

gauche - sinistra - izquierda

SS-2P-F



**D14426**

droit - destra - derecha

SS-2P-F

## DXLC8 p. 158



**D12712**

gauche - sinistra - izquierda

POS-2P-F



**D12711**

droit - destra - derecha

POS-2P-F

## ASR p. 274

 12/24V

Standard



**630120**

87 dB



07/2012 ->



Fixation 4 vis M6 (190x60mm)  
Fijación 4 tornillos M6 (190x60mm)  
4 vite di fissaggio M6 (190x60mm)



**153270**  
(OE 1372699080)

gauche - sinistra - izquierda



AMP 1.5-7P-M

arrière  
connettore posteriore  
conector trasero



**153280**  
(OE 1372698080)

droit - destra - derecha



**D11868** AMP 1.5-7P-F



**052500**  
gauche - sinistra - izquierda



**052500**  
droit - destra - derecha



**193360**  
(OE 1356794080 / 71749250)

SS-2P-M



**193170**  
(OE 1305797)

SS-2P-M



**001916**



**D13880** SS-2P-F

SS-2P-F

## LC12 LED p. 138



**161000**   
gauche - sinistra - izquierda



**AMP 1.5-7P-M**  
arrière  
connettore posteriore  
conector trasero



**161010**   
droit - destra - derecha

## LC8T p. 157



**156040**    
gauche - sinistra - izquierda



**AMP 1.5-7P-M**  
arrière  
connettore posteriore  
conector trasero



**156050**    
droit - destra - derecha



**D11868** **AMP 1.5-7P-F**



**056700**   
gauche - sinistra - izquierda



**056710**   
droit - destra - derecha



**001830** 

## BL15 p. 171



**NEW**



**165040**  
gauche - sinistra - izquierda



**DT04-4P-M**



**DTM06-4S-4P-F**

**NEW**



**165050**  
droit - destra - derecha



**D14436** **DT06-4S-4P-F**



**D14437** **DTM06-4S-4P-F**



**D14435** **DTM04-4P-M**

## EPP96 LED p. 180



**D13609** 400 mm  
**CLICK-IN**

# FRUEHAUF

## EPP96

 p. 181



**196020** R10W



**D11888** 1000 mm  
**CLICK-IN**

## DXLC8

 p. 158



**D12712** 350 mm  
gauche - sinistra - izquierda **POS-2P-F**



**D12711** 350 mm  
droit - destra - derecha **POS-2P-F**

## FA3 LED

 p. 207

**LED**

 12/24V



**D14427** 1500 mm  
gauche - sinistra - izquierda **CLICK-IN**



**D14428** 1500 mm  
droit - destra - derecha **CLICK-IN**

## SMD04

 p. 196

**LED**

 24V



**104130** 500 mm **K**

**104140** 1500 mm **K**

**CLICK-IN**



**104090** 500 mm **K**

**104100** 1500 mm **K**

**CLICK-IN**

## 5054

 p. 292



Max 6 kg

**D14538**

## LC12 LED



p. 138

LED

24V



**161000**

gauche - sinistra - izquierda



**AMP 1.5-7P-M**  
arrière  
connettore posteriore  
conector trasero



**161010**

droit - destra - derecha



**D11868** **AMP 1.5-7P-F**



**D14781**

gauche - sinistra - izquierda

**SS-2P-F**



**D14782**

droit - destra - derecha

**SS-2P-F**

## LC8T



p. 157



**156040**

gauche - sinistra - izquierda



**AMP 1.5-7P-M**  
arrière  
connettore posteriore  
conector trasero



**156050**

droit - destra - derecha



**056700**

gauche - sinistra - izquierda



**056710**

droit - destra - derecha



**D12712**

gauche - sinistra - izquierda

**POS-2P-F**



**D12711**

droit - destra - derecha

**POS-2P-F**



**D11868** **AMP 1.5-7P-F**

## EPP96 LED



p. 180

LED

24V



**R14364**

2000 mm

**SS-2P-F**

# GUILLEN

## EPP96

 p. 181



**D11888**

1000 mm

CLICK-IN

## SMD04

 p. 196

LED

 24V



**104100**

1500 mm 

CLICK-IN



**104650**

1000 mm 

bride rallongée - supporto esteso - soporte extendido

CLICK-IN

## SMCU

 p. 144

 12/24V



**D14722**

SS-2P-M SS-3P-M

## FA3LED

 p. 207

LED

 12/24V



**D14427**

1500 mm

gauche - sinistra - izquierda

CLICK-IN



**D14428**

1500 mm

droit - destra - derecha

CLICK-IN

## GX

### LC6

 p. 170



**166500**





PE  
arrière  
connettore posteriore  
conector trasero



**066500**



cabochon - lente - tulipa

### LC7

 p. 166



**167150**

(OE 2773801/2870801)



**067000**

(OE 3156201)

cabochon - lente - tulipa

### FE81

 p. 212



**181000**

(OE 0190408700)



**181050**

(OE 0190552400)

### FE85

 p. 194



**185020**

(OE 5010217022)



**185050**

(OE 5010104837)

### FE95

 p. 193



**195030**

(OE 5010271501)



**195060**

(OE 5010312524)



### FPL93

 p. 200



**193020**  
(OE 190825600)

**K**

**JPT-2P-M**



**001726**



**D13876**

**JPT-2P-F**

### ICDL94

 p. 187



**119550**

**JPT-3P-M**



**001616**



**D13877**

**JPT-3P-F**



**001626**

# HYUNDAI CONSTRUCTION EQUIPMENT

## CHL 1 LED p. 242

LED

 12/24V



**D14324**  
gauche - sinistra - izquierda



**DT-6P-M**  
arrière  
connettore posteriore  
conector trasero



**D14325**  
droit - destra - derecha



**D14352** **DT-6P-F**

## CHL 1 H4 p. 243

 24V  
H4 - PY21 - W5W



**D14320** 12V  
**D14322** 24V  
gauche - sinistra - izquierda



**DT-6P-M**  
arrière  
connettore posteriore  
conector trasero



**D14321** 12V  
**D14323** 24V  
droit - destra - derecha



**D14352** **DT-6P-F**

## SL 1500 p. 223

LED

 12/24V

 1500 Lumen



**D14971**  
**DT-2P-M**



**D14170** **DT-2P-F**

# HYUNDAI CONSTRUCTION EQUIPMENT

## SH3

 p. 236

 H3/70W  
24V



**D14156**

**DT-2P-M**



**D14170**

**DT-2P-F**

## ATLAS

 p. 252

**LED**

 9/32V



**212460**



## STRALIS / TRAKKER

### LC11



 p. 140

**LED**

 24V

03/2016 ->





**160150**    
(OE 5802062689 / 5802240291)  
gauche - sinistra - izquierda





**HDSCS-8P-M**  
latéral  
connettore laterale  
conector lateral





**160100**    
(OE 5802000573 / 5802240295)  
droit - destra - derecha





**160080**     
(OE 5802000568 / 5802240292)  
gauche - sinistra - izquierda



**160090**     
(OE 5802000767 / 5802240296)  
droit - destra - derecha

03/2016 ->





**160110**    
(OE 5802000570 / 5802240293)  
gauche - sinistra - izquierda





**HDSCS-8P-M**  
arrière  
connettore posteriore  
conector trasero





**160130**    
(OE 5802000770 / 5802240297)  
droit - destra - derecha



**160140**     
(OE 5802055273 / 5802240294)  
gauche - sinistra - izquierda



**160120**     
(OE 5802000772 / 5802240298)  
droit - destra - derecha



**D13878** **HDSCS-8P-F**





**060000**   
gauche - sinistra - izquierda



**060010**   
droit - destra - derecha

03/2016 ->





**155450**  
(OE 5801637199)     
gauche - sinistra - izquierda





**HDSCS-8P-M**  
latéral  
connettore laterale  
conector lateral



**155460**  
(OE 5801637201)    
droit - destra - derecha





**155470**  
(OE 5801637202)     
droit - destra - derecha

DESIGN EFFET FUMÉ - MÉTALLISÉ  
DESIGN METALLIZZATO - FUMATO  
DISEÑO EFECTO AHUMADO - METALIZADO

03/2016 ->



**155480**  
(OE 5801637182)    
gauche - sinistra - izquierda





**HDSCS-8P-M**  
arrière  
connettore posteriore  
conector trasero



**155490**  
(OE 5801757328)    
droit - destra - derecha



**155540**  
(OE 5802055272)     
gauche - sinistra - izquierda



**155500**  
(OE 5801757326)     
droit - destra - derecha



**D13878** **HDSCS-8P-F**



**055040**   
gauche - sinistra - izquierda



**055050**   
droit - destra - derecha



**001830**   
Alarme sonore de recul  
Cicalino di retromarcia  
Alarma sonora de marcha atrás

## STRALIS - TRAKKER - EUROCARGO

### LC5

 p.161

06/2011 -> EURO 6



**153220**  
(OE 5801426889)   
gauche - sinistra - izquierda





**AMP 1.5-7P-M**  
arrière  
connettore posteriore  
conector trasero





**153210**  
(OE 5801426894)   
droit - destra - derecha



**153200**  
(OE 5801426912)    
gauche - sinistra - izquierda





**153230**  
(OE 5801426917)    
droit - destra - derecha



**153240**  
(OE 5801426975)   
gauche - sinistra - izquierda



**153250**  
(OE 5801426977)   
droit - destra - derecha

**153260**  
(OE 5801426979)    
droit - destra - derecha



**D11868** **AMP 1.5-7P-F**



**052500**  
(OE 42566495)   
gauche - sinistra - izquierda



**052500**  
(OE 42535711)   
droit - destra - derecha

### FPL93

 p. 200



**193020**  
(OE 500308514)   
**JPT-2P-M**



**001726**  
(OE 1608352)



**D13876** **JPT-2P-F**

### SMD98

 p. 197

-> 10/2014

 LED

 24V





**198760**  
(OE 5801631615)   
**SS-2P-M**



**D13880** **SS-2P-F**

09/2011 -> EURO 6





**169390**  
(OE 5801363428)    
gauche - sinistra - izquierda





**DIN-8P-M**  
arrière  
connettore posteriore  
conector trasero





**169410**  
(OE 5801363431)    
droit - destra - derecha



**169400**  
(OE 5801363430)     
gauche - sinistra - izquierda



**169420**  
(OE 5801363432)     
droit - destra - derecha



**067500**  
(OE 93161844)   
gauche - sinistra - izquierda



**067500**  
(OE 93161844)   
droit - destra - derecha



**D12953** 

## STRALIS - TRAKKER - ASTRA HD7/HD8

09/2012 ->



**110550**  
(OE 5801572024)  
gauche - sinistra - izquierda



**110560**  
(OE 5801572018)  
droit - destra - derecha



**001619**



**193170**  
(OE 41200664)   
superseal **SS-2P-M**



**001916**



**D13880** **SS-2P-F**



## STRALIS - TRAKKER - ASTRA HD7/HD8

### LC7

 p.167

2002 ->





**168610**  
(OE 99463244)    
gauche - sinistra - izquierda





IVECO  
arrièr  
connettore posteriore  
conector trasero



**168600**  
(OE 99463242)    
droit - destra - derecha



**168480**  
(OE R504083205)     
droit - destra - derecha



**067500**  
(OE 93161844)   
gauche - sinistra - izquierda



**067500**  
(OE 93161844)   
droit - destra - derecha



**D12953** 

### C199

 p.183

2002 -> 05/2007



**119920**  
(OE 41221041)  
gauche - sinistra - izquierda



**119930**  
(OE 41221040)  
droit - destra - derecha

### C105

 p.183

05/2007 -> 09/2012



**110520**  
(OE 42555042)  
gauche - sinistra - izquierda



**110530**  
(OE 42555041)  
droit - destra - derecha



**001619**



1996 ->



**168590**  
(OE 99463243)

gauche - sinistra - izquierda



IVECO  
arrièrè  
connettore posteriore  
conector trasero



**168600**  
(OE 99463242)

droit - destra - derecha



**168610**  
(OE 99463244)

gauche - sinistra - izquierda



**067500**  
(OE 93161844)

gauche - sinistra - izquierda



**067500**  
(OE 93161844)

droit - destra - derecha



06/2008 -> 09/2012



**110520**  
(OE 42555042)

gauche - sinistra - izquierda

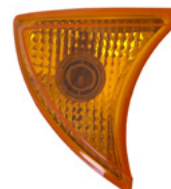

**110530**  
(OE 42555041)

droit - destra - derecha

09/2012 ->



**110550**  
(OE 5801572024)

gauche - sinistra - izquierda



**110560**  
(OE 5801572018)

droit - destra - derecha



**001619**



## EUROSTAR - EUROTECH - EUROTRAKKER

### LC7

 p.166

1996 -> 2002





**168610**  
(OE 99463244)     
gauche - sinistra - izquierda



IVECO  
arrièrè  
connettore posteriore  
conector trasero



**168600**  
(OE 99463242)    
droit - destra - derecha



**067500**  
(OE 93161844)   
gauche - sinistra - izquierda





**067500**  
(OE 93161844)   
droit - destra - derecha

### FPL93

 p.200



**193020**  
(OE 500308514)   



**001726**  
(OE 1608352)



**D13876** 

## MASSIF 4 X 4

### LC5

 p.161

2002 ->



**152180**  
(OE 791123)   
gauche - sinistra - izquierda



  
arrièrè  
connettore posteriore  
conector trasero



**152180**  
(OE 791123)   
droit - destra - derecha



**D11868** 



**052500**  
(OE A610067-002)   
gauche - sinistra - izquierda



**052500**  
(OE A610067-002)   
droit - destra - derecha

06/2006 ->



**D12334**  
(OE 69500032)

gauche - sinistra - izquierda



**AMP 1.5-6P-M**  
arrière  
connettore posteriore  
conector trasero



**D12335**  
(OE 69500026)

droit - destra - derecha



**D11868** **AMP 1.5-7P-F**



**D12336**  
(OE 42555132)

gauche - sinistra - izquierda



**D12337**  
(OE 42555131)

droit - destra - derecha



## 725V

06/2006 ->



**D12338**  
(OE 69500591)

3.5T 

**D12340**  
(OE 69500047)

5T 

gauche - sinistra - izquierda



**D12339**  
(OE 69500590)

3.5T 

**D12341**  
(OE 69500044)

5T 

droit - destra - derecha

1999 -> 06/2006



**D11482**  
(OE 500356783)

gauche - sinistra - izquierda



**AMP 1.5-5P-M**  
arrière  
connettore posteriore  
conector trasero



**D11481**  
(OE 500356782)

droit - destra - derecha



**D11868** **AMP 1.5-7P-F**



**D11480**

gauche - sinistra - izquierda



**D11479**

droit - destra - derecha



## DAILY

### LC7

 p. 167

1996 -> 1999



**168590**  
(OE 99463243)

gauche - sinistra - izquierda



IVECO  
arrière  
connettole posteriore  
conector trasero



**168600**  
(OE 99463242)

droit - destra - derecha



**067500**  
(OE 93161844)



gauche - sinistra - izquierda



**067500**  
(OE 93161844)



droit - destra - derecha

## 725

 p. 173



**725040**



gauche - sinistra - izquierda

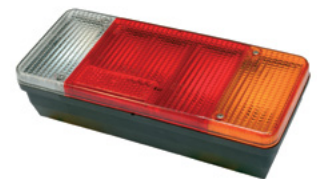

**725010**



droit - destra - derecha



**725002**



gauche - sinistra - izquierda

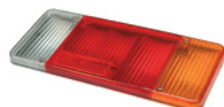

**725012**



droit - destra - derecha

### FPL93

 p. 200

1996 ->



**193020**  
(OE 500308514)

**K**

**JPT-2P-M**



**001726**  
(OE 1608352)



**D13876**

**JPT-2P-F**



**193290**  
(OE 504097923)

**K**

**SS-2P-M**



**D13880**

**SS-2P-F**

### FE94

 p. 204

1999 ->



**198060**  
(OE 500341613)

**JPT-2P-M**



**D13876**

**JPT-2P-F**



**001586**

## SEDDON EUROMOVER

### LC7

 p. 167

1996 -> 1999



**168590**  
(OE 99463243)

gauche - sinistra - izquierda



IVECO  
arrière  
connettore posteriore  
conector trasero



**168600**  
(OE 99463242)

droit - destra - derecha



**067500**  
(OE 93161844)



gauche - sinistra - izquierda

**067500**  
(OE 93161844)



droit - destra - derecha

### ICDL94

 p. 187



**119550**  
(OE 97163920)





**001616**  
(OE 5001834568)



**D13877**



### ICDL94

 p. 187



**119550**  
(OE 5001020257)

JPT-3P-M



**001616**  
(OE 5001834568)



**D13877**

JPT-3P-F



**001626**  
(OE 5001837993)

### FE95

 p. 193



**195030**  
(OE 5001834505)



**195060**  
(OE 5001834576)

### SMD98

 p. 197

LED

 24V



**198650**  
(OE 504217797)



JPT-2P-M



**D13876**

JPT-2P-F

URBAN WAY

ICDL94

i | p. 187



**119550**  
(OE 5001020257)

JPT-3P-M



**001616**  
(OE 5001834568)



**D13877** JPT-3P-F



**001626**  
(OE 5001837993)

SMD98

i | p. 197

LED

⚡ 24V



**198650**  
(OE 504217797)

K

JPT-2P-M



**D13876** JPT-2P-F

R312 - R332

LC6

i | p. 170



**166500** K



**066500** K



# IVECO BUS

R312 - R332

## LC7

 p. 166



**167150**  
(OE 5010179915)



**067000**

## FE81

 p. 212



**181000**  
(OE 5000461058)



**181050**  
(OE 5000461059)

## AGORA - CITELIS

## LC7

 p. 166

**167150**  
(OE 5010179915)



**067000**

## ICDL94

 p. 187



**119550**  
(OE 5001020257)

JPT-3P-M



**001616**  
(OE 5001834568)



**D13877**

JPT-3P-F



**001626**  
(OE 5001837993)

AGORA - CITELIS

SMD98

i p.197

LED  
24V



**198650**  
(OE 504217797) **K**  
JPT-2P-M



**D13876** JPT-2P-F

FPL93

i p.200



**193020**  
(OE 5010306792) **K**  
JPT-2P-M



**001726**  
(OE 5001847589)



**D13876** JPT-2P-F

FE85

i p.194



**185020**  
(OE 5010217022)



**185050**  
(OE 5010104837)

FE95

i p.193



**195030**  
(OE 5001834505)



**195060**  
(OE 5001834576)

2751

i p.181



**D14517** C5W

### FPL93

 p. 200



**193020**  
(OE 5010306792)

**K**

**JPT-2P-M**



**001726**  
(OE 5001847589)



**D13876** **JPT-2P-F**

### FE81

 p. 212



**181000**  
(OE 5000461058)



**181050**  
(OE 5000461059)

### BD95



**195000**  
(OE 5010286898)



**001606**  
(OE 5001834564)

### FE95

 p. 193



**195030**  
(OE 5001834505)



**195060**  
(OE 5001834576)

## ARES / ILIADE

### ICDL94

 p. 187



**119550**  
(OE 5001020257)

JPT-3P-M



**001616**  
(OE 5001834568)



**D13877**

JPT-3P-F



**001626**  
(OE 5001837993)

### FPL93

 p. 200



**193020**  
(OE 5010306792)

**K**

JPT-2P-M



**001726**  
(OE 5001847589)



**D13876**

JPT-2P-F

## FR1

### FM91



**191170 - P21W**  
(OE 5010197259)

feu de recul  
luce di retromarcia  
piloto marcha atrás



**191140 - P21W**  
(OE 5010197261)

feu de position  
luce di posizione posteriore  
piloto de posición trasero



**191120 - P21W**  
(OE 5010197262)

Feu stop  
Luce di stop  
Piloto de stop



**191150 - P21W**  
(OE 50101972564)

Feu clignotant arrière  
Luce intermittente posteriore  
Piloto intermitente



**191110 - P21W**  
(OE 5010197260)

Feu de brouillard  
Luce retronebbia  
Piloto antiniebla

## PEGASUS p.254

LED

 10/30V



**D14725**  
(OE W20TS01684)



## GALAXY p.260

LED

 10/30V



**D14749**  
(OE W20TS01401)



**D14513**  
(OE W20TS00777)

## LC12T LED

 p. 138

LED

 24V



**161000**  
gauche - sinistra - izquierda



**AMP 1.5-7P-M**  
arrière  
connettore posteriore  
conector trasero



**161010**  
droit - destra - derecha



**D11868** **AMP 1.5-7P-F**



**D11689** **AMP 1.5-7P**

## LC12 LED

 p. 138

LED

 24V



**161260**  
gauche - sinistra - izquierda



**AMP 1.5-7P-M**  
arrière  
connettore posteriore  
conector trasero



**161270**  
droit - destra - derecha



**D11868** **AMP 1.5-7P-F**



**D11689** **AMP 1.5-7P**

## LC8T

 p. 157



**156040**  
gauche - sinistra - izquierda



**AMP 1.5-7P-M**  
arrière  
connettore posteriore  
conector trasero



**156050**  
droit - destra - derecha



**D11868** **AMP 1.5-7P-F**



**056700**  
gauche - sinistra - izquierda



**056710**  
droit - destra - derecha



**D11689** **AMP 1.5-7P**

# LAMBERET

## LC8

 p.154



**156310**

gauche - sinistra - izquierda



**AMP 1.5-7P-M**

arrière  
connettole posteriore  
conector trasero



**156300**

droit - destra - derecha



**D11868**

**AMP 1.5-7P-F**



**056500**

gauche - sinistra - izquierda



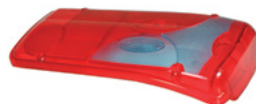

**056510**

droit - destra - derecha





**D11689**

**AMP 1.5-7P**

## LC5T

 p.164



**153000**

gauche - sinistra - izquierda





**AMP 1.5-7P-M**

arrière  
connettole posteriore  
conector trasero



**153010**

droit - destra - derecha





**D11868**

**AMP 1.5-7P-F**



**053700**

gauche - sinistra - izquierda





**053710**

droit - destra - derecha



## LPL18

 p.179

 LED



12/24V

**NEW**



**199040**

**SS-2P-M**



**D13880**

**SS-2P-F**

## EPP96 LED

 p. 180

LED

 24V



**D13874** 2000 mm

POS-2P-F

## EPP96

 p. 181



**196020**



**D10227** 700 mm

POS-2P-F

## FE04

 p. 202

LED

 24V



**104330** 500 mm

## SMD04

 p. 196

LED

 24V



**104130** 500 mm 

CLICK-IN



**104090** 500 mm 

**104100** 1500 mm 

CLICK-IN



**104170** 500 mm 

CLICK-IN



**D14214**

POS-2P-M



# LAMBERET

## SMD98 p.197

LED

 24V



**D10496** 1500 mm 

CLICK-IN



**001716**

## FA3 LED p.207

LED

 12/24V



**D13875** 1000 mm

## SL 1000 p.219

LED

 12/24V



**NEW**



**D14880**

## RCL 1200 p.250

LED

 9/30V

 1200 Lumen

**NEW**



**300010**

**NEW**



**300000**

chromé - cromato - cromado

## MDJ p.306



**175020**

## BL15-CTL15

 p. 145

**LED**

 24V



Exemple de montage - Esempio di montaggio - Ejemplo de montaje

**NEW**



**164050**  
(OE 661058)

**NEW**



**164010**  
Pour raccordement sur feu BL15  
Per collegamento su fanale BL15  
Para conectar sobre piloto BL15

**NEW**



**165020**  
gauche - sinistra - izquierda

**NEW**



**165030**  
droit - destra - derecha



**D14436** DT06-4S-4P-F    **D14437** DTM06-4S-4P-F    **D14435** DTM04-4P-M

## FCA

 p. 307



**D11689** AMP 1.5-7P

## LC8T p. 157



**156250**

gauche - sinistra - izquierda



AMP 1.5-7P-M

arrière  
connettore posteriore  
conector trasero



**156260**

droit - destra - derecha



**156380**

gauche - sinistra - izquierda



**156390**

droit - destra - derecha



**D11868**

AMP 1.5-7P-F



**056720**

gauche - sinistra - izquierda



**056730**

droit - destra - derecha



## LC5T p. 164



**153000**

gauche - sinistra - izquierda



AMP 1.5-7P-M

arrière  
connettore posteriore  
conector trasero



**153010**

droit - destra - derecha



**153130**

droit - destra - derecha



**D11868**

AMP 1.5-7P-F



**053700**

gauche - sinistra - izquierda



**053710**

droit - destra - derecha



## LC12T LED

 p. 138

LED

 24V



**161000**

gauche - sinistra - izquierda





AMP 1.5-7P-M

arrière  
connettore posteriore  
conector trasero



**161010**

droit - destra - derecha





**D11868**

AMP 1.5-7P-F



**D11689**

AMP 1.5-7P

## SMD04

 p. 196

LED

 24V



**104140**

1500 mm 

CLICK-IN



**104100**

1500 mm 

CLICK-IN



**104250**

500 mm 

CLICK-IN

## FPL93

 p. 193



**193200**



JPT-2P-M



**001726**



**D13876**

JPT-2P-F

## SMD98

 p. 197

LED

 24V



**D10494**

500 mm 



**001786**

500 mm 

# LINDE

## SL 1000

 p. 222

**LED**

 12/24V

 1000 Lumen



**D14970**

**DT-2P-M**



**D14170**

**DT-2P-F**

## QL LED

 p. 239

**LED**

 12/24V-100V



**D14769**



**D14770**



**D14771**



**DT-2P-M**



**D14170**

**DT-2P-F**

## FRESNEL

 p. 259

**LED**

 10/110V



**D14746**



## LC12 LED



p. 138

LED



24V



**161000**



gauche - sinistra - izquierda



AMP 1.5-7P-M

arrière  
connettore posteriore  
conector trasero



**161010**



droit - destra - derecha



**D11868**

AMP 1.5-7P-F



**D14781**

SS-2P-F

gauche - sinistra - izquierda



**D14782**

SS-2P-F

droit - destra - derecha

## SL 1000



p. 219

LED



12/24V



**D14857**

DT-2P-M

Feu homologué recul - Luce di retromarcia omologati  
- Piloto marcha atrás homologado





**D14170**

DT-2P-F

04/2017 ->  
12V





**155550**    
(OE 65.25225-6004 / 7CE 945 095)  
gauche - sinistra - izquierda



**AMP 1.5-7P-M**  
arrière  
connettore posteriore  
conector trasero





**155560**    
(OE 65.25225-6005 / 7CE 945 096)  
droit - destra - derecha

## TGA - TGL - TGM - TGX

2005 ->





**156200**     
(OE 8125225-6544)  
gauche - sinistra - izquierda

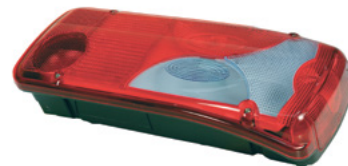

**AMP 1.5-7P-M**  
latéral  
connettore laterale  
conector lateral



**156210**    
(OE 8125225-6545)  
droit - destra - derecha

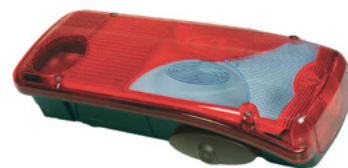

**156220**     
(OE 8125225-6547)  
droit - destra - derecha



**D11868** **AMP 1.5-7P-F**



**056500**   
(OE 8125229-6059 / 65.25229.0000 / 7CE 945 111)  
gauche - sinistra - izquierda

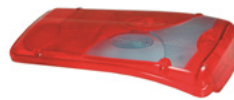

**056510**   
(OE 8125229-6060 / 65.25229.001 / 7CE 945 112)  
droit - destra - derecha



**001830** 90 Db  
**001872** 55-90 Db

 LED

 10/110V

03/2018 ->



**212020**   
(OE 81.25207-6074)  
**POS-2P-M**



**212030**   
(OE 81.25207-6075)  
**POS-2P-M**



**D13879** **POS-2P-F**



L - M - F

LC7

 p. 166

1990 -> 2004



**168090**  
(OE 8125225-6033)    
gauche - sinistra - izquierda





**DIN 72480-8P-M**  
arrière  
connettore posteriore  
conector trasero



**168090**  
(OE 8125225-6464)    
droit - destra - derecha



**168100**  
(OE 8125225-6034)     
gauche - sinistra - izquierda



**168490**  
(OE 8125225-6528)     
droit - destra - derecha



**067500**  
(OE 8125229-6051)   
gauche - sinistra - izquierda



**067500**  
(OE 8125229-6051)   
droit - destra - derecha



TGA

LC7

 p. 166

1999 -> 2005



**169180**  
(OE 8125225-6526)    
gauche - sinistra - izquierda





**AMP 1.5-7P-M**  
latéral  
connettore laterale  
conector lateral



**169170**  
(OE 8125225-6523)    
droit - destra - derecha



**169160**  
(OE 8125225-6524)     
gauche - sinistra - izquierda



**169190**  
(OE 8125225-6530)     
droit - destra - derecha



**D11868** **AMP 1.5-7P-F**



**067500**  
(OE 8125229-6051)   
gauche - sinistra - izquierda



**067500**  
(OE 8125229-6051)   
droit - destra - derecha





**166700**  
(OE 8125225-6469)



gauche - sinistra - izquierda



PE  
arrière  
connettore posteriore  
conector trasero



**166700**  
(OE 8125225-6470)



droit - destra - derecha



**066500**



gauche - sinistra - izquierda



**066500**



droit - destra - derecha

## MANISCOPIC

### LC5

 p. 161

2001 ->



**152180**  
(OE 661973 / 223767)

gauche - sinistra - izquierda





**AMP 1.5-7P-M**

arrière  
connettore posteriore  
conector trasero



**152180**  
(OE 661973 / 223766)

droit - destra - derecha





**D11868** **AMP 1.5-7P-F**



**052500**  
(OE 661973)

gauche - sinistra - izquierda





**052500**  
(OE 661973)

droit - destra - derecha



## MSI

### BBS516

 p. 175

1999 ->



**500930**  
(OE 163782)

gauche - sinistra - izquierda



PF  
arrière  
connettore posteriore  
conector trasero



**500940**  
(OE 163783)

droit - destra - derecha

### 2751

 p. 181



**D14517**  
(OE 227330)

## CHL 1 LED

 p. 242

**LED**

 12/24V



**D14380**  
(OE 959694 / 52562043)

gauche - sinistra - izquierda



**DT-6P-M**

arrière  
connettore posteriore  
conector trasero



**D14381**  
(OE 959695 / 52562044)

droit - destra - derecha



**D14352** **DT-6P-F**

**LED**

**NEW**



9/32V



**212520**





## GROVE

### LC8

 p. 152



**156860**  
(OE 03137250)   

gauche - sinistra - izquierda



**AMP 1.5-7P-M**

arrière  
connettore posteriore  
conector trasero



**156870**  
(OE 03137251)  

droit - destra - derecha



**D11868** **AMP 1.5-7P-F**



**056540** 

gauche - sinistra - izquierda



**056550** 

droit - destra - derecha





**001830**  
(OE 03137254) 

### LC5

 p. 163



**152170**  
(OE 03320939)  

gauche - sinistra - izquierda



**AMP 1.5-7P-M**

arrière  
connettore posteriore  
conector trasero



**152180**  
(OE 03320938) 

droit - destra - derecha



**D11868** **AMP 1.5-7P-F**



**052500** 

gauche - sinistra - izquierda



**052500** 

droit - destra - derecha

### SMD98

 p. 197

**LED**

 24V



**198660**  
(OE 03138527) 

**JPT-2P-M**



**198520**  
(OE 03320937) 

**JPT-2P-M**



**D10493**  
(OE 03329572) 500 mm 

**CLICK-IN**



**198640**  
(OE 03329492) 

**JPT-2P-M**



**D13876** **JPT-2P-F**

vignal-group.com

08/2020 ->

**NEW**



**212710**  
(OE A 960 820 02 58 / A 960 820 03 58)



**MQS-2P-M**

## ZETROS

09/2019 ->

**NEW**



**155590**  
(OE A 959 544 01 03)     
gauche - sinistra - izquierda





**AMP 1.5-7P-M**

arrière  
connettore posteriore  
conector trasero



**NEW**



**155600**  
(OE A 959 544 02 03)    
droit - destra - derecha

**NEW**



**155610**  
(OE A 959 544 03 03)     
droit - destra - derecha



**D11868** **AMP 1.5-7P-F**



**056540**   
(OE A 000 826 20 56)  
gauche - sinistra - izquierda



**056550**   
(OE A 000826 21 56)  
droit - destra - derecha



**001830**  
Alarme sonore de recul  
Cicalino di retromarcia  
Alarma sonora de marcha atrás

## SPRINTER

### LC11



 p. 140

03/2018 ->

**LED**

 12V



**160400**  
(OE A 910 820 64 00)   



gauche - sinistra - izquierda



**AMP 1.5-7P-M**

arrière  
connettore posteriore  
conector trasero



**160410**  
(OE A 910 820 65 00)  

droit - destra - derecha



**D11868** **AMP 1.5-7P-F**



**060000**  
(OE A 910 826 10 00) 

gauche - sinistra - izquierda



**060010**  
(OE A 910 826 11 00) 



droit - destra - derecha

### LC8

 p. 153

06/2006 ->



**156340**  
(OE A 906 820 04 64)   



gauche - sinistra - izquierda



**AMP 1.5-7P-M**

arrière  
connettore posteriore  
Anschlusskasten hinten



**156350**  
(OE A 906 820 17 64)  

droit - destra - derecha



**D11868** **AMP 1.5-7P-F**



**056540**  
(OE A 000 826 20 56) 

gauche - sinistra - izquierda



**056550**  
(OE A 000 826 21 56) 

droit - destra - derecha

## ATLAS



 p. 252

03/2018 ->

**LED**



 9/32V



**212010**  
(OE A 910 906 29 00 / A 910 906 64 00)  

**KOSTAL-2P-M**



**212420**  
(OE A 910 906 69 00)  

### SMD98

 p. 197

04/2019->

**LED**

 24V

**NEW**



**198760**  
(OE A 956 544 00 11)

**K**

**SS-2P-M**



**D13880**

**SS-2P-F**

### FE08 H1

04/2019->

**LED**

 24V

**NEW**



**116200**  
(OE A 956 820 00 59)

## SONDERFAHRZEUG

### EPP96

 p. 181

06/2012 -> Lowliner



**196170**  
(OE A 949 540 01 04) 500 mm

**HDSCS-3P-M**

## VEGA LED

 p. 256

LED

 10/30V



**D14508**  
(OE 116119)



**D14513**  
(OE 115856)

## VEGA

 p. 261

 H1 -12/24V



**D14479**  
(OE 115855)



**D14513**  
(OE 115856)



## LPL18

 p. 179

**LED**

**NEW**



12/24V

08/2020 ->



**199000**  
(OE 47363002)

**SS-2P-M**



**D13880**

**SS-2P-F**

## SMD98

 p. 197

**LED**



12V

08/2018->



**198810**  
(OE 5141966)

**K**

**SS-2P-M**



**D13880**

**SS-2P-F**

## RH3

 p. 236



H3/70W  
12V

08/2018 ->



**D14654**  
(OE 51431987)

**DT-2P-M**



**D14170**

**DT-2P-F**

## FT

 p. 234

**LED**



12/24V

07/2017 ->



**D14191**  
(OE 47826594)





**D14192**

## NT400 - CABSTAR - ATLEON

### LC5

 p. 161



**152170**  
(OE 26555-9X126)    
gauche - sinistra - izquierda





**AMP 1.5-7P-M**  
arrière  
connettore posteriore  
conector trasero



**152180**  
(OE 26555-9X125)   
droit - destra - derecha



**153120**  
(OE 26555-9X128)    
droit - destra - derecha



**D11868** **AMP 1.5-7P-F**



**052500**  
(OE 26554-9X126)   
gauche - sinistra - izquierda



**052500**  
(OE 26554-9X126)   
droit - destra - derecha

## ICDL94

 p. 187



**119550**  
(OE 26164-9X402) **JPT-3P-M**



**001616**  
(OE 26244-9X400)



**D13877** **JPT-3P-F**

## LC12 LED p. 138

LED

 24V



**161280**

gauche - sinistra - izquierda



AMP 1.5-7P-M

arrière  
connettore posteriore  
conector trasero



**161290**

droit - destra - derecha



**D11868**

AMP 1.5-7P-F



**D14781**

gauche - sinistra - izquierda



**D14782**

droit - destra - derecha



SS-2P-F

## EPP96 LED p. 180

LED

 12/24V



**R14364**

SS-2P-M

## SMD04 p. 196

LED

 12/24V

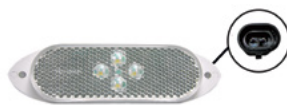

**104690**

**K**

SS-2P-M



**104670**

**K**

SS-2P-M



**D13880**

SS-2P-F

## CARBONLUX

 p. 220

LED

**NEW**

 10/30V

 R23



**D14811**

DT-2P-M



Interrupteur - interruttore - interruptor



**D14170**

DT-2P-F

## 5054

 p. 292



Max 6 kg

**D14538**

04/2010 ->



**152180**  
(OE 4421265)



gauche - sinistra - izquierda



**AMP 1.5-7P-M**

arrière  
connettore posteriore  
conector trasero



**152180**  
(OE 4421266)



droit - destra - derecha



**D11868** **AMP 1.5-7P-F**



**052500**



gauche - sinistra - izquierda



**052500**



droit - destra - derecha

04/2010 ->



**196010**  
(OE 4421269)

**JPT-2P-M**



**D13876** **JPT-2P-F**

07/2012 ->



Fixation 4 vis M6 (190x60mm)  
Fijación 4 tornillos M6 (190x60mm)  
4 vite di fissaggio M6 (190x60mm)



**153270**   
(OE 6350FS / 9815127080)

gauche - sinistra - izquierda



**AMP 1.5-7P-M**  
arrière  
connettore posteriore  
conector trasero



**153280**   
(OE 6351FS / 9815126980)

droit - destra - derecha



**D11868** **AMP 1.5-7P-F**



**052500** 

gauche - sinistra - izquierda



**052500** 

droit - destra - derecha

# RENAULT TRUCKS

EURO 6 - T / K / C

LC9 LED

 p. 142



EURO 6

LED

 24V

12/2017->





**158030**  
(OE 7425982261 / 7422800385 /  
7484585208)   

gauche - sinistra - izquierda





**AMP 1.5-7P-M**  
latéral  
connettore laterale  
conector lateral



**158050**  
(OE 7425982262 / 7423080010 /  
7484585206)  

droit - destra - derecha



**158040**  
(OE 7425982262 / 7422800386 /  
7484585204)   

droit - destra - derecha



**D11868** **AMP 1.5-7P-F**



**058000**  
(OE 7422800391) 

gauche - sinistra - izquierda



**058000**  
(OE 7422800391) 

droit - destra - derecha

ATLAS

 p. 252

LED

 9/32V

09/2021->

**NEW**



**212740**  
(OE 23811106)  **AMP-4P-F**

**NEW**



**212750**  
(OE 23811107)  **AMP-4P-F**

TRI

 p. 217



**D10596**  
(OE 7423374865)

## EURO 6 - T / K / C --> 520 CH

LC9 ⓘ p. 160

### EURO 6

11/2013 ->



**159010**  
(OE 7420802348) K FPL EPP  
gauche - sinistra - izquierda



**AMP 1.5-7P-M**  
latéral  
connettore laterale  
conector lateral



**159020**  
(OE 7420802350) K FPL  
droit - destra - derecha



**159030**  
(OE 7420802353) K FPL Speaker  
droit - destra - derecha



**D11868** **AMP 1.5-7P-F**



**059000**  
(OE 7420802418) K  
gauche - sinistra - izquierda



**059000**  
(OE 7420802418) K  
droit - destra - derecha



**D12953** Speaker

## LC10 LED ⓘ p. 143

### EURO 6

LED

24V

09/2020->



Entraxe : 152 mm  
Distanza tra le viti posteriori : 152 mm  
Distancia entre tornillos : 152 mm

**NEW**



**159500**  
(OE 7423530440) K FPL EPP  
gauche - sinistra - izquierda



**AMP 1.5-7P-M**  
latéral  
connettore laterale  
conector lateral

**NEW**



**159530**  
(OE 7423530442) K FPL  
droit - destra - derecha

**NEW**



**159520**  
(OE 7423530438) K FPL  
gauche - sinistra - izquierda

**NEW**



**159510**  
(OE 7423530441) K Speaker  
droit - destra - derecha



**D11868** **AMP 1.5-7P-F**



**059500**  
(OE 7423292490) K  
gauche - sinistra - izquierda



**059500**  
(OE 7423292490) K  
droit - destra - derecha



# RENAULT TRUCKS

EURO 6 - T / K / C --> 520 CH

## FE09

EURO6

11/2013 ->



**115020**  
(OE 7482346591)  
gauche - sinistra - izquierda



**115020**  
(OE 7482346591)  
droit - destra - derecha



**115000**  
(OE 7482252506)  
gauche - sinistra - izquierda



**115010**  
(OE 7482367030)  
droit - destra - derecha



**115040**  
(OE 7482252291)



**115030**  
(OE 7482255014)

## SL08

EURO6

11/2013 ->



**113020**  
(OE 7482266219) 10W  
Lampe de portière  
Luce di portiera  
Piloto de puerta



**113030**  
(OE 7482285707) 5W  
Feu d'embranchement  
Luce d'identificazione apertura porte  
Piloto identificación apertura puertas

## SMD00

 p. 198

EURO6

LED

 24V

12/2013->



**198620**  
(OE 7482392733)   
Cuve blanche - cabochon PMMA  
Scatola bianca - lente PMMA  
Caja blanca - tulipa PMMA



**198740**  
(OE 7482586940)   
Cuve ambre - cabochon PC haute température  
Scatola arancione - lente PC temperatura elevata  
Caja naranja - tulipa PC temperatura alta

## EURO 6 - T / K / C --> 520 CH

### SHD 1200

 p. 227

#### EURO 6

**LED**

 9/36V

07/2014 ->



**D14161**  
(OE 7484185589)

**DT-2P-M**



**D14170**

**DT-2P-F**

### SH3

 p. 237

#### EURO 6

11/2013 ->



\* Lampe fournie

\* Con lampada

\* Lámpara incluida



**D13019 \***  
(OE 7421396991)

**DT-2P-M**



**D14170**

**DT-2P-F**

## MAGNUM

### LC9

 p. 160

01/2006 ->



**159010**  
(OE 7420802348)

gauche - sinistra - izquierda

**K FPL EPP**



**AMP 1.5-7P-M**

latéral  
connettore laterale  
conector lateral



**159020**  
(OE 7420802350)

droit - destra - derecha

**K FPL**



**159030**  
(OE 7420802353)

droit - destra - derecha

**K FPL**



**D11868**

**AMP 1.5-7P-F**



**059000**  
(OE 7420802418)

gauche - sinistra - izquierda

**K**



**059000**  
(OE 7420802418)

droit - destra - derecha

**K**



**D12953**

**FPL**

09/2004 -> 01/2006



**169310**  
(OE 5001864535)

  

gauche - sinistra - izquierda



**AMP 1.5-7P-M**

latéral  
connettore laterale  
conector lateral

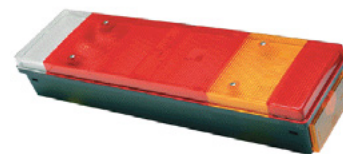

**169320**  
(OE 5001864536)

droit - destra - derecha



Entraxe : 160 mm  
Distanza tra le viti posteriori : 160 mm  
Distancia entre tornillos : 160 mm

12/1998 -> 09/2004



**169020**  
(OE 5001847586)

gauche - sinistra - izquierda



**AMP 1.5-7P-M**

latéral  
connettore laterale  
conector lateral



**169030**  
(OE 5001847587)



droit - destra - derecha



**169000**  
(OE 5001847584)

gauche - sinistra - izquierda



**169010**  
(OE 5001847585)

droit - destra - derecha



**D11868** **AMP 1.5-7P-F**



**067000**  
(OE 5000296594)

**067500**  
(OE 5001847588)

gauche - sinistra - izquierda



**067000**  
(OE 5000296594)

**067500**  
(OE 5001847588)

droit - destra - derecha



**D12953**



## MAGNUM

### LC7

 p. 166

1990 -> 1994



**167100**  
(OE 5000296592)

gauche - sinistra - izquierda





PE  
arrière  
guarnizione pressacavo  
posteriore  
presa estopa trasero



**167000**  
(OE 5000296592)

droit - destra - derecha

1994 -> 12/1998



**168220**  
(OE 5001831194)

gauche - sinistra - izquierda



**168260**  
(OE 5001832999)

droit - destra - derecha



**067000**  
(OE 5000296594)

**067500**  
(OE 5001847588)

gauche - sinistra - izquierda





**067000**  
(OE 5000296594)

**067500**  
(OE 5001847588)

droit - destra - derecha



### LC6

 p. 170

1991 -> 12/1998



**166100 \***  
(OE 5000296591)

gauche - sinistra - izquierda





PE  
arrière  
guarnizione pressacavo  
posteriore  
presa estopa trasero



**166000 \***  
(OE 5000296591)

droit - destra - derecha

12/1998 -> 09/2004



**169060**  
(OE 5001847582)

gauche - sinistra - izquierda





AMP 1.5-7P-M  
latéral  
connettore laterale  
conector lateral



**169070**  
(5001847583)

droit - destra - derecha



**D11868** AMP 1.5-7P-F



**066000**  
(OE 5000296593)

gauche - sinistra - izquierda



**066000**  
(OE 5000296593)

droit - destra - derecha

# RENAULT TRUCKS

## MAGNUM

### FE85

 p. 194

1991 ->



**185020**  
(OE 5010217022)  
gauche - sinistra - izquierda



**185020**  
(OE 5010217022)  
droit - destra - derecha

1991 -> 12/1998



**185040**  
(OE 5010217023) 5W  
gauche - sinistra - izquierda



**185040**  
(OE 5010217023) 5W  
droit - destra - derecha

12/1998 ->



**185160**  
(OE 5010271807) 21W  
gauche - sinistra - izquierda



**185160**  
(OE 5010271807) 21W  
droit - destra - derecha

### FE04

 p. 190

**LED**

 24V

06/2008 ->



**104570**  
(OE 7421430181/7482562006)

**DT-2P-M**



**104450**  
(OE 7421137718)

**DT-2P-M**



**D14170**

**DT-2P-F**

### FPL93

 p. 200

1994 ->



**193020**  
(OE 5010306792 / 7484538758) **K**  
**JPT-2P-M**



**001726**  
(OE 5001847589)



**D13876**

**JPT-2P-F**

## MAGNUM

### FE02

 p. 193

2003 ->



**102200**  
(OE 5001862030)   
Clippé - fissaggio con clip - fijación con clip  
**JPT-2P-M**



**001726**  
(OE 5001847589)



**D13876** **JPT-2P-F**

### SH3

 p. 237

10/2009 ->



- \* Lampe fournie
- \* Con lampada
- \* Lámpara incluida



**D13019 \***  
(OE 7421396991) **DT-2P-M**



**D14170** **DT-2P-F**

## PREMIUM / KERAX / EURO 6 - C --> 320 CH



### LC9

 p. 160

### EURO 6

01/2006 ->



**159010**  
(OE 7420802348)     
gauche - sinistra - izquierda



**AMP 1.5-7P-M**  
latéral  
connettore laterale  
conector lateral



**159020**  
(OE 7420802350)    
droit - destra - derecha



**159030**  
(OE 7420802353)     
droit - destra - derecha



**D11868** **AMP 1.5-7P-F**



**059000**  
(OE 7420802418)   
gauche - sinistra - izquierda



**059000**  
(OE 7420802418)   
droit - destra - derecha



**D12953** 

Premium  
09/2004 -> 01/2006  
Kerax  
09/2004 -> 09/2006



Entraxe : 160 mm  
Distanza tra le viti posteriori : 160 mm  
Distancia entre tornillos : 160 mm



**169310**  
(OE 5001864535)



gauche - sinistra - izquierda



AMP 1.5-7P-M

latéral  
connettore laterale  
conector lateral

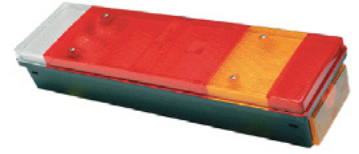

**169320**  
(OE 5001864536)



droit - destra - derecha



**D11868**

AMP 1.5-7P-F



**067500**  
(OE 5001847588)



gauche - sinistra - izquierda



**067500**  
(OE 5001847588)



droit - destra - derecha

Premium  
1999 -> 09/2004



**169020**  
(OE 5001847586)



gauche - sinistra - izquierda



AMP 1.5-7P-M

latéral  
connettore laterale  
conector lateral

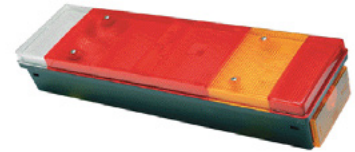

**169030**  
(OE 5001847587)



droit - destra - derecha

Premium  
1999 -> 09/2004  
Kerax  
09/1998 -> 09/2004



**169000**  
(OE 5001847584)



gauche - sinistra - izquierda



**169010**  
(OE 5001847585)



droit - destra - derecha



**D11868**

AMP 1.5-7P-F



**067000**  
(OE 5000296594)

**067500**  
(OE 5001847588)



gauche - sinistra - izquierda



**067000**  
(OE 5000296594)

**067500**  
(OE 5001847588)



droit - destra - derecha



**D12953**



## PREMIUM / KERAX

### LC7

 p. 166

Premium  
1995 -> 1999  
Kerax  
1995 -> 09/1998





**168220**  
(OE 5001831194)  



 **168260**  
(OE 5001832999)   
gauche - sinistra - izquierda

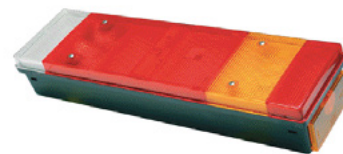

PE  
arrière  
guarnizione pressacavo  
posteriore  
presa estopa trasero



**168260**  
(OE 5001832999) 

 **168140**  
(OE 5001835853)    
droit - destra - derecha



**067000**  
(OE 5000296594)  
gauche - sinistra - izquierda





**067000**  
(OE 5000296594)  
droit - destra - derecha

## LC5

Premium  
06/2001 -> 09/2004



**152020 \***  
(OE 5001846847) 

 **152510 \*\***  
(OE 5001857964)   
gauche - sinistra - izquierda



**AMP 1.5-7P-M**  
arrière  
connettore posteriore  
conector trasero



**152500 \*\***  
(OE 5001858092)

 **152520 \***  
(OE 5001857965)  
droit - destra - derecha

\* pas de fonction recul  
\* no retromarcia  
\* no marcha atrás

\*\* pas de fonction brouillard  
\*\* no retronebbia  
\*\* no antiniebla



**D11868** **AMP 1.5-7P-F**

**052000**  
(OE 5010392231)  
gauche - sinistra - izquierda

**052000**  
(OE 5010392231)  
droit - destra - derecha



# RENAULT TRUCKS

## PREMIUM / KERAX

### LC6

 p. 170

Premium  
12/1998 -> 09/2004



\* Silent blocs non fournis,  
voir réf. 001706 p. 170

\* Silent blocs non inclusi,  
vedi rif. 001706 p. 170

\* Silent blocs no incluidos,  
ver ref. 001706 p. 170



**169060**  
(OE 5001847582)



gauche - sinistra - izquierda



AMP 1.5-7P-M

latéral  
connettore laterale  
conector lateral



**169070**  
(OE 5001847583)

droit - destra - derecha

Premium  
1995 -> 12/1998



Kerax  
1995 -> 09/1998



**166100 \***  
(OE 5000296591)



gauche - sinistra - izquierda



PE  
arrière  
guarnizione pressacavo  
posteriore  
presa estopa trasero



**166000 \***  
(OE 5000296591)

droit - destra - derecha



**D11868** AMP 1.5-7P-F



**066000**  
(OE 5000296593)

gauche - sinistra - izquierda



**066000**  
(OE 5000296593)

droit - destra - derecha

## PREMIUM / KERAX / EURO 6 - C --> 320 CH

### FE95

 p. 193

### EURO6

1995 ->



**195010**  
(OE 5001834561)

gauche - sinistra - izquierda



**195010**  
(OE 5001834561)

droit - destra - derecha

PREMIUM / KERAX / EURO 6 - C --> 320 CH

## ICDL94



p. 187

### EURO 6

1995 ->



**119450**  
(OE 5001834565)

5W

JPT-3P-M



**119470**  
(OE 5001847597)

21W

JPT-3P-M

Premium 12/1998 ->  
Kerax 1999 ->



**001616**  
(OE 5001834568)



**D13877**

JPT-3P-F

## FE02



p. 193

### EURO 6

2003 ->



**102200**  
(OE 5001862030)

K

Clippé - fissaggio con clip - fijación con clip

JPT-2P-M



**001726**  
(OE 5001847589)



**D13876**

JPT-2P-F

## SMD98



p. 197

### EURO 6

LED

24V

09/2007 ->



**198650**  
(OE 7421106206)

K

Feu d'identification Viscope  
Luce di posizione Viscope  
Piloto de identificación Visera

JPT-2P-M



**D13876**

JPT-2P-F

# RENAULT TRUCKS

PREMIUM / KERAX / EURO 6 - C --> 320 CH

## FPL93

 p. 193

2003 ->



**193200**  
(OE 5001862030)

Vissé - Avviato - Atornillado

**JPT-2P-M**

1995 ->



**193020**  
(OE 5010306792)

**JPT-2P-M**



**001726**  
(OE 5001847589)



**D13876** **JPT-2P-F**

## SH3

 p. 237



24V

10/2009 ->



- \* Lampe fournie
- \* Con lampada
- \* Lámpara incluida



**D13019 \***  
(OE 7421396991)

**DT-2P-M**



**D14170** **DT-2P-F**

## MIDLINER

### LC4

 p. 171



**141500**  
(OE 5000808172)

gauche - sinistra - izquierda

**K EPP**



PE  
arrière  
guarnizione pressacavo pos-  
teriore  
prensa estopa trasero



**141500**  
(OE 5000808172)

droit - destra - derecha

**K EPP**



**040500**  
(OE 5000808166)

gauche - sinistra - izquierda

**K**



**040500**  
(OE 5000808166)

droit - destra - derecha

**K**

EURO 6 - D --> 18 T

LC10 LED  p. 143

EURO6

LED

 24V



09/2020->

 Entraxe : 152 mm  
Distanza tra le viti posteriori : 152 mm  
Distancia entre tornillos : 152 mm



**NEW**



**159500**  
(OE 7423530440)     
gauche - sinistra - izquierda



**AMP 1.5-7P-M**  
latéral  
connettore laterale  
conector lateral



**NEW**



**159530**  
(OE 7423530442)    
droit - destra - derecha

**NEW**



**159520**  
(OE 7423530438)    
gauche - sinistra - izquierda

**NEW**



**159510**  
(OE 7423530441)     
droit - destra - derecha



**D11868** **AMP 1.5-7P-F**



**059500**  
(OE 7423292490)   
gauche - sinistra - izquierda



**059500**  
(OE 7423292490)   
droit - destra - derecha

LC5



 p. 161

EURO6

09/2021->

**NEW**



**152170**  
(OE 5010595381)    
gauche - sinistra - izquierda



**AMP 1.5-7P-M**  
arrière  
connettore posteriore  
conector trasero

**NEW**



**152180**  
(OE 5010595382)   
droit - destra - derecha



**D11868** **AMP 1.5-7P-F**



**052500**  
(OE 5001847153)   
gauche - sinistra - izquierda



**052500**  
(OE 5001847153)   
droit - destra - derecha

# RENAULT TRUCKS

## MIDLUM / EURO 6 - D --> 18 T

### LC7

 p. 166

1999 -> 04/2006



**169000**

(OE 5001847584)

gauche - sinistra - izquierda



AMP 1.5-7P-M

latéral  
connettore laterale  
conector lateral

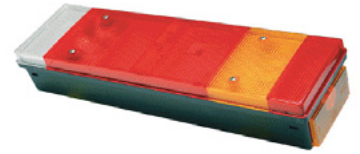

**169010**

(OE 5001847585)

droit - destra - derecha



**D11868**

AMP 1.5-7P-F



**067500**

(OE 5001847588)

gauche - sinistra - izquierda



**067500**

(OE 5001847588)

droit - destra - derecha



### LC5

 p. 163

### EURO 6

09/2005 ->



**152880**

(OE 7420862032)

gauche - sinistra - izquierda



AMP 1.5-7P-M

arrière  
connettore posteriore  
conector trasero



**152880**

(OE 7420862035)

droit - destra - derecha



1999 -> 09/2005



\* pas de fonction recul  
\* no retromarcia  
\* no marcha atrás

\*\* pas de fonction brouillard  
\*\* no retronebbia  
\*\* no antiniebla



**152000 \***

(OE 5001846843)

gauche - sinistra - izquierda



**152040 \*\***

(OE 5001846845)

gauche - sinistra - izquierda



**152010 \*\***

(OE 5001846844)

droit - destra - derecha



**152050 \***

(OE 5001846846)

droit - destra - derecha



**D11868**

AMP 1.5-7P-F



**052500**

(OE 5001847153)

gauche - sinistra - izquierda



**052500**

(OE 5001847153)

droit - destra - derecha



## MIDLUM / EURO 6 - D --> 18 T

### LC5

 p. 161

### EURO 6

09/2005 ->



**152190**  
(OE 7420862038)

gauche - sinistra - izquierda





AMP 1.5-7P-M

arrière  
connettore posteriore  
conector trasero



**152200**  
(OE 7420862041)

droit - destra - derecha

1999 -> 09/2005



\* pas de fonction recul  
\* no retromarcia  
\* no marcha atrás

\*\* pas de fonction brouillard  
\*\* no retronebbia  
\*\* no antiniebla



**152020 \***  
(OE 5001846847)



**152060 \*\***  
(OE 5001846849)

gauche - sinistra - izquierda







**152030 \*\***  
(OE 5001846848)



**152070 \***  
(OE 5001846850)

droit - destra - derecha



**D11868** AMP 1.5-7P-F



**052000**  
(OE 5010392231)

gauche - sinistra - izquierda



**052000**  
(OE 5010392231)

droit - destra - derecha

### EPP96

 p. 181

1999 -> 2003



**196020**  
(OE 7700353021)

### EPP98

 p. 181

### EURO 6

2003 ->



**196010**  
(OE 5010293829)





**D13876**



# RENAULT TRUCKS

MIDLUM / EURO 6 - D --> 18 T

## FM91

08/2008 ->



**191170**  
(OE 7421268609)

## ICDL94

 p. 187

## EURO 6

-> 1999

1999 ->



**119450**  
(OE 5001834565)

5W

**JPT-3P-M**



**119470**  
(OE 5001847597)

21W

**JPT-3P-M**



**001616**  
(OE 5001834568)



**D13877**

**JPT-3P-F**

## FE95

 p. 193

## EURO 6

1999 ->



**195010**  
(OE 5001834561)

gauche - sinistra - izquierda



**195010**  
(OE 5001834561)

droit - destra - derecha

## FE02

 p. 193

## EURO 6

2003 ->



**102200**  
(OE 5001862030)

**K**

Clippé - fissaggio con clip - fijación con clip

**JPT-2P-M**



**001726**  
(OE 5001847589)



**D13876**

**JPT-2P-F**

## MIDLUM / EURO 6 - D --> 18 T

### FPL93

 p. 200

1999 ->



**193020**  
(OE 5010306792)



JPT-2P-M



**193280**  
(OE 7420894265)



JPT-2P-M



**001726**  
(OE 5001847589)



**D13876** JPT-2P-F

## MAXITY / EURO 6 - D --> 7,5 T

### LC5

 p. 161

### EURO6

2009 ->



**152170**  
(OE 7485118470)

gauche - sinistra - izquierda



AMP 1.5-7P-M

arrière  
connettore posteriore  
conector trasero



**152180**  
(OE 5001870556)



droit - destra - derecha



**D11868** AMP 1.5-7P-F



**052500**  
(OE 5001847153)



gauche - sinistra - izquierda



**052500**  
(OE 5001847153)



droit - destra - derecha



# RENAULT TRUCKS

## MASCOTT

### LC5

#### EURO 6

04/2006 ->



**152880**  
(OE 7420862032)

gauche - sinistra - izquierda



AMP 1.5-7P-M

arrière  
connettore posteriore  
conector trasero



**152880**  
(OE 7420862035)

droit - destra - derecha



07/2001 -> 04/2006

\* pas de fonction recul  
\* no retromarcia  
\* no marcha atrás

\*\* pas de fonction brouillard  
\*\* no retronebbia  
\*\* no antiniebla



**152000 \***  
(OE 5001846843)

gauche - sinistra - izquierda



**152600 \*\***  
(OE 5001858093)

droit - destra - derecha



**D11868** AMP 1.5-7P-F



**052500**  
(OE 5001847153)

gauche - sinistra - izquierda



**052500**  
(OE 5001847153)

droit - destra - derecha



### LC5

 p. 161

04/2006 ->



**152170**

gauche - sinistra - izquierda



AMP 1.5-7P-M

arrière  
connettore posteriore  
conector trasero



**152180**

droit - destra - derecha



**D11868** AMP 1.5-7P-F



**052500**  
(OE 5001847153)

gauche - sinistra - izquierda



**052500**  
(OE 5001847153)

droit - destra - derecha



## MASCOTT

### LC5

07/2001 -> 04/2006

\* pas de fonction recul  
\* no retromarcia  
\* no marcha atrás

\*\* pas de fonction brouillard  
\*\* no retronebbia  
\*\* no antiniebla



**152020 \***  
(OE 5001846847) EPP

 **152510 \*\***  
(OE 5001857964) EPP

gauche - sinistra - izquierda



AMP 1.5-7P-M

arrière  
connettore posteriore  
conector trasero



**152500 \*\***  
(OE 5001858092)

 **152520 \***  
(OE 5001857965)

droit - destra - derecha



**D11868** AMP 1.5-7P-F



**052000**  
(OE 5010392231)  
gauche - sinistra - izquierda



**052000**  
(OE 5010392231)  
droit - destra - derecha

### LC4

 p.171

1998 -> 07/2001



**141500**  
(OE 5000808172) K EPP  
gauche - sinistra - izquierda



PE  
arrière  
guarnizione pressacavo pos-  
teriore  
presa estopa trasero



**141500**  
(OE 5000808172) K EPP  
droit - destra - derecha



**040500**  
(OE 5000808166) K  
gauche - sinistra - izquierda



**040500**  
(OE 5000808166) K  
droit - destra - derecha

### EPP98

 p.181

1998 ->



**196010**  
(OE 5010293829)

JPT-2P-M



**D13876** JPT-2P-F

# RENAULT TRUCKS

## MASCOTT

### ICDL94

 p. 187

1998 ->



**119450**  
(OE 5001834565) 5W  
**JPT-3P-M**



**001616**  
(OE 5001834568)



**D13877** **JPT-3P-F**

### SMD98

 p.197

**LED**



4xLEDS - 12V

1998 ->



**198510**  
(OE 7700377208) **K**  
**JPT-2P-M**



**D13876** **JPT-2P-F**

### CA

 p. 216

1998 -> 04/2006

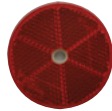

**D14590**  
(OE 7700377130)

04/2006 ->

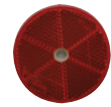

**D14593**  
(OE 8200602314)

## TRAFIC

### LC5

 p. 161

10/2014 ->



**152180**  
(OE 265551402R) **K**

**152180**  
(OE 265550674R) **K** 

gauche - sinistra - izquierda



**AMP 1.5-7P-M**

arrière  
connettore posteriore  
conector trasero



**152180**  
(OE 265504514R) **K**

**152180**  
(OE 265500292R) **K** 

droit - destra - derecha



**D11868** **AMP 1.5-7P-F**



**052500**  
(OE 5001847153) **K**

gauche - sinistra - izquierda



**052500**  
(OE 5001847153) **K**

droit - destra - derecha

## MASTER



### LC5

 p. 161

04/2010 ->



**152180**  
(OE 265551402R) 

**152180**  
(OE 265550674R)  

gauche - sinistra - izquierda



AMP 1.5-7P-M

arrière  
connettore posteriore  
conector trasero



**152180**  
(OE 265504514R) 

 **152180**  
(OE 265500292R) 

droit - destra - derecha



**D11868** AMP 1.5-7P-F



**052500**  
(OE 5001847153) 

gauche - sinistra - izquierda



**052500**  
(OE 5001847153) 

droit - destra - derecha

## EPP96

 p. 181

-> 04/2010



**196020**  
(OE 7700353021)

## EPP98

 p. 181

-> 04/2010



**196010**  
(OE 265100848R)

JPT-2P-M



**D13876** JPT-2P-F

## SMD98

 p.197

LED

 4xLEDS - 12V

-> 04/2010



**198580** 

JPT-2P-M



**D13876** JPT-2P-F

# RENAULT TRUCKS

## GAMME B

### LC4

 p.171



**141000**

(OE 5000808171)

gauche - sinistra - izquierda





PE  
arrière  
guarnizione pressacavo pos-  
teriore  
presa estopa trasero



**141000**

(OE 5000808171)

droit - destra - derecha





**040000**

(OE 5000807304)

gauche - sinistra - izquierda

**040000**

(OE 5000807304)

droit - destra - derecha

### FE85

 p.194



**185020**

(OE 5010217022)

gauche - sinistra - izquierda



**185020**

(OE 5010217022)

droit - destra - derecha

### FPL93

 p.200



**193020**

(OE 5010306792 / 7484538758)







**001726**

(OE 5001847589)



**D13876**



## GAMME C

### LC4

 p.171

-> 1986



**141500**  
(OE 5000808172)

gauche - sinistra - izquierda



PE  
arrière  
guarnizione pressacavo pos-  
teriore  
presa estopa trasero



**141500**  
(OE 5000808172)

droit - destra - derecha



**040500**  
(OE 5000808166)

gauche - sinistra - izquierda



**040500**  
(OE 5000808166)

droit - destra - derecha



### FE81

 p.212



**181050**  
(OE 5000461059)



**181000**  
(OE 5000461058)

### FE88

 p.211



**188310**  
(OE 5000623050)



**088010**  
(OE 5000296718)

# RENAULT TRUCKS

## GAMME G

### LC4

 p. 171

-> 1986



**141000**  
(OE 5000808171)



**141500**  
(OE 5000808172)

gauche - sinistra - izquierda



PE  
arrière  
guarnizione pressacavo pos-  
teriore  
prensa estopa trasero



**141000**  
(OE 5000808171)



**141500**  
(OE 5000808172)

droit - destra - derecha



**040000**  
(OE 5000807304)

**040000**  
(OE 5000807304)

**040500**  
(OE 5000808166)



gauche - sinistra - izquierda

**040500**  
(OE 5000808166)



droit - destra - derecha

### LC6

 p. 170

1986 ->



**166000**  
(OE 5000296591)



gauche - sinistra - izquierda



PE  
arrière  
guarnizione pressacavo  
posteriore  
prensa estopa trasero



**166000**  
(OE 5000296591)

droit - destra - derecha



**066000**  
(OE 5000296593)

gauche - sinistra - izquierda

**066000**  
(OE 5000296593)

droit - destra - derecha

## GAMME J

### FE81

 p. 212



**181050**  
(OE 5000461059)



**181000**  
(OE 5000461058)

### FE88

 p. 211



**188310**  
(OE 5000623050)



**088010**  
(OE 5000296718)

### FPL93

 p. 200



**193020**  
(OE 5010306792 / 7484538758) 

 JPT-2P-M



**001726**  
(OE 5001847589)



**D13876**  JPT-2P-F



# RENAULT TRUCKS

## GAMME R

### LC7

 p. 166

1994 ->



**167100**  
(OE 5000296592)

gauche - sinistra - izquierda





PE  
arrière  
guarnizione pressacavo  
posteriore  
presa estopa trasero



**167000**  
(OE 5000296592)

droit - destra - derecha



**168220**  
(OE 5001831194)

gauche - sinistra - izquierda



**168260**  
(OE 5001832999)

droit - destra - derecha



**067000**  
(OE 5000296594)

**067500**  
(OE 5001847588)

gauche - sinistra - izquierda





**067000**  
(OE 5000296594)

**067500**  
(OE 5001847588)

droit - destra - derecha



### LC4

 p. 171

-> 1994



**141000**  
(OE 5000808171)

gauche - sinistra - izquierda





PE  
arrière  
guarnizione pressacavo pos-  
teriore  
presa estopa trasero



**141000**  
(OE 5000808171)

droit - destra - derecha





**040000**  
(OE 5000807304)

gauche - sinistra - izquierda



**040000**  
(OE 5000807304)



droit - destra - derecha

## GAMME R

### FPL93

 p. 200



**193020**  
(OE 5010306792 / 7484538758)   



**001726**  
(OE 5001847589)



**D13876** 

## GAMME S

### LC4

 p. 171



**141000**  
(OE 5000808171)   
gauche - sinistra - izquierda



PE  
arrière  
guarnizione pressacavo pos-  
teriore  
presa estopa trasero



**141000**  
(OE 5000808171)   
droit - destra - derecha



**040000**  
(OE 5000807304)  
gauche - sinistra - izquierda



**040000**  
(OE 5000807304)  
droit - destra - derecha

### FE87

 p. 211



**188310**  
(OE 5000623050)



**088010**  
(OE 5000296718)

10/2020 ->

 LED

 9/32V

**NEW**



**212420**



## SERIE P&R

### LC8

 p. 152

08/2013 ->



**155080**  
(OE 2160128)

gauche - sinistra - izquierda



AMP 1.5-7P-M

arrière  
connettore posteriore  
conector trasero



**155520**  
(OE 2340796)

droit - destra - derecha



**155090**  
(OE 2160127)

droit - destra - derecha

01/2007 ->



**156770**  
(OE 1756754/2021579/2129985)

gauche - sinistra - izquierda



AMP 1.5-7P-M

latéral  
connettore laterale  
conector lateral



**156780**  
(OE 1756751/2021575/2129987)

droit - destra - derecha



**155020**  
(OE 2021578/2129986)

droit - destra - derecha



**156790**  
(OE 1791369/2021576/2129988)

droit - destra - derecha



**D11868** AMP 1.5-7P-F



**056540**  
(OE 1784669/2129992)



gauche - sinistra - izquierda



**056550**  
(OE 1784670/2129991)



droit - destra - derecha



**001830**





### LC7

 p. 168

1990 -> 1998



**168350**  
(OE 1365963)     
gauche - sinistra - izquierda

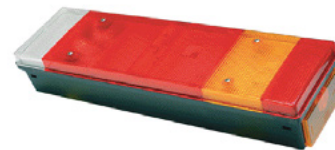

**168360**  
(OE 1365964)    
droit - destra - derecha



**067500**  
(OE 1350343)   
gauche - sinistra - izquierda



**067500**  
(OE 1350343)   
droit - destra - derecha

### SLA 2000

 p. 223

 LED

**NEW**



12/24V



2000 Lumen



**D14852**  
(OE 2862201)  



**D14170** 

### SH3

 p. 237



- \* Lampe fournie
- \* Con lampada
- \* Lámpara incluida

**D13019 \***  
(OE 7421396991)  



**D14170** 

### TRI

 p. 217



**D10596**  
(OE 2020496)

## LC12 LED

 p. 138

**LED**

 24V

**GLOWING**



**NEW**



**161280**  
(OE 1370066)

gauche - sinistra - izquierda



**AMP 1.5-7P-M**  
arrière  
connettore posteriore  
conector trasero

**NEW**



**161290**  
(OE 1370067)

droit - destra - derecha



**D11868** **AMP 1.5-7P-F**

## LC12 LED

 p. 138

**LED**

 24V

**ORIGINAL**



**161000**  
(OE 1302341 / 1364736)

gauche - sinistra - izquierda



**AMP 1.5-7P-M**  
arrière  
connettore posteriore  
conector trasero



**161010**  
(OE 1302342 / 1364737)

droit - destra - derecha



**D11868** **AMP 1.5-7P-F**

## LCR19

 p. 146

**LED**

 24V

**SMC**

Position lateral clignotant  
Posizione laterale lampeggiante  
Posición lateral e intermitente

**POS**

Position  
Posizione  
Posición

**RI**

Resistance integree (contrôle défaillance indicateur)  
Resistenza integrata (controllo errore intermittente)  
Resistencia integrada (control de fallo del intermitente)

**NEW**



**213010**  
(OE 1415545)

**AMP MCP-4P-M**

Position Glowing - Stop - Clignotant  
Posizione Glowing - Stop - Indicatore  
Posición Glowing - Stop - Intermitente

**NEW**





**213090**  
(OE 1415546)

**AMP MCP-4P-M**

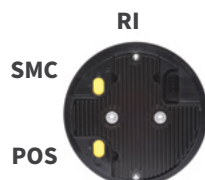
Position Glowing - Stop - Clignotant  
Posizione Glowing - Stop - Indicatore  
Posición Glowing - Stop - Intermitente



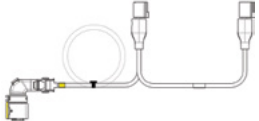
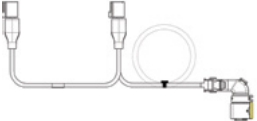

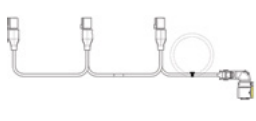
<b>AMP-MCP-4P-F</b> 	<b>AMP-MCP-4P-F</b> 	<b>AMP-MCP-4P-F</b> 	<b>AMP-MCP-4P-F</b> 
<b>D14846</b> (OE 1415543) <b>HDSCS-6P-F</b> gauche - sinistra - izquierda	<b>D14847</b> (OE 1415544) <b>HDSCS-6P-F</b> droit - destra - derecha	<b>D14884</b> (OE 1437099) <b>HDSCS-6P-F</b> gauche - sinistra - izquierda	<b>D14885</b> (OE 1437100) <b>HDSCS-6P-F</b> droit - destra - derecha



10/30V



**D14488**  
(OE 1348566)



## LC12 LED

 p. 138

LED

 24V



**161000**

gauche - sinistra - izquierda



AMP 1.5-7P-M

arrière  
connettore posteriore  
conector trasero



**161010**

droit - destra - derecha



**D11868**

AMP 1.5-7P-F



**D14781**

gauche - sinistra - izquierda



**D14782**

droit - destra - derecha

SS-2P-F

SS-2P-F

## LC8T

 p. 157



**156040**

gauche - sinistra - izquierda



AMP 1.5-7P-M

arrière  
connettore posteriore  
conector trasero



**156050**

droit - destra - derecha



**056700**

gauche - sinistra - izquierda



**056710**

droit - destra - derecha



**D12712**

gauche - sinistra - izquierda

POS-2P-F



**D12711**

droit - destra - derecha

POS-2P-F



**D11868**

AMP 1.5-7P-F

## EPP96 LED

 p. 180

LED

 24V



**R14364**

2000 mm

SS-2P-F



# SOR IBERICA

## EPP96

 p. 181



**D11888**

1000 mm

**CLICK-IN**

## SMD04

 p. 196

**LED**

 24V



**104100**

1500 mm

**CLICK-IN**



**104650**

1000 mm

bride rallongée - supporto esteso - soporte extendido

**CLICK-IN**

## SMCU

 p. 196

 12/24V



**D14722**

**SS-2P-M SS-3P-M**

## FA3LED

 p. 207

**LED**

 12/24V



**D14427**

1500 mm

gauche - sinistra - izquierda

**CLICK-IN**



**D14428**

1500 mm

droit - destra - derecha

**CLICK-IN**



**D14425**

gauche - sinistra - izquierda

**SS-2P-F**



**D14426**

droit - destra - derecha

**SS-2P-F**

## SH3

 p. 236

 H3/55W  
12V

09/2017 ->



**D14156**  
(OE 48159167) 



**D14170** 

## RH3

 p. 236

 H3/55W  
12V

01/2021 ->



**D14654**  
(OE 51431987) 



**D14170** 

# STILL

## CL 1 LED

 p. 244

LED

 12/24V



**D14649**

## RL 1000

 p. 225

LED

 12/24V

 1000 Lumen



**D14853**

DT-2P-M



**D14170**

DT-2P-F

## SHD BLUE

 p. 239

LED

 12/24V-100V



**D14249**

DT-2P-M



**D14170**

DT-2P-F

## FRESNEL

 p. 259

LED

 10/110V



**D14746**



## BL15

 p. 145

LED

 24V

**NEW**



DT04-4P-M



DTM06-4S-4P-F

**NEW**



**165040**

gauche - sinistra - izquierda

**165050**

droit - destra - derecha



**D14436**

DT06-4S-4P-F



**D14437**

DTM06-4S-4P-F



**D14435**

DTM04-4P-M



**R14338**

DT06-4S-4P-F

## CTL15

 p. 144

LED

 24V

**NEW**



DT04-4P-M



DTM06-4S-4P-F

**NEW**



**164020**

gauche - sinistra - izquierda

**164030**

droit - destra - derecha



**D14436**

DT06-4S-4P-F



**D14437**

DTM06-4S-4P-F



**D14435**

DTM04-4P-M



**R14339**

DT06-4S-4P-F

## CTL15-BL15

 p. 145

LED

 24V

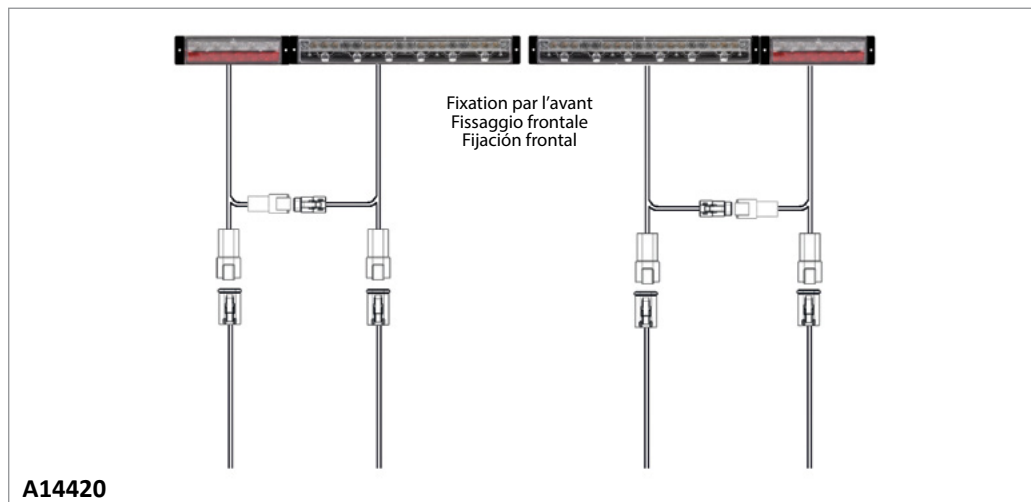

**A14420**

2 x CTL15 + 1 x BL15 gauche + 1 x BL15 droit + 4 câbles 8,5 m  
 2 x CTL15 + 1 x BL15 sinistro + 1 x BL15 destro + 4 cavi 8,5 m  
 2 x CTL15 + 1 x BL15 izquierdo + 1 x BL15 derecho + 4 cables 8,5 m

# UD TRUCKS

## QUON - QUESTER

### LC5

 p. 163

05/2015 ->



**153860**  
(OE 261319Z01B) 

**153880 \***  
(OE 261319Z01D) 

gauche - sinistra - izquierda



AMP 1.5-7P-M

arrière  
connettore posteriore  
conector trasero



**153870**  
(OE 261319Z01C) 

**153890 \***  
(OE 261319Z01E) 

droit - destra - derecha

\* pas de fonction brouillard  
\* no retronebbia  
\* no antiniebla



**D11868** AMP 1.5-7P-F



**052500**  
(OE 265509Z00A) 

gauche - sinistra - izquierda



**052500**  
(OE 265509Z00A) 

droit - destra - derecha

### EPP98

 p. 181

05/2015 ->



**196010**  
(OE 265109Z00A)

JPT-2P-M



**D13876** JPT-2P-F

### ICDL15

 p. 186

05/2015 ->



**120000**  
(OE 84655961) PY21W - 24V

SS-2P-M



**D13880** SS-2P-F

## CHL 1 LED p. 242

LED

 12/24V



**D14324**  
(OE 101 4 734)  
gauche - sinistra - izquierda



**DT-6P-M**  
arrière  
connettore posteriore  
conector trasero



**D14325**  
(OE 101 4 735)  
droit - destra - derecha



**D14352** **DT-6P-F**

## CARBONLUX p. 230

LED

 10/30V



**D14548**  
(OE 101 1 102)

**DT-2P-M**



**D14170** **DT-2P-F**

## VEGA LED p. 256

LED

 10/30V



**D14508**  
(OE 101 4 681)



**D14509**  
(OE 101 4 211)



## VEGA p. 261

 H1 -12/24V



**D14478**  
(OE 101 2 421)



### LC8

 p. 158

06/2017 ->



**155570**

(OE 7CA 945 095)

gauche - sinistra - izquierda



AMP 1.5-7P-M

arrière  
connettore posteriore  
conector trasero



**155580**

(OE 7CA 945 096)

droit - destra - derecha



**D11868**

AMP 1.5-7P-F



**055020**

(OE 7CA 945 111)

gauche - sinistra - izquierda





**055030**

(OE 7CA 945 112)

droit - destra - derecha



### LC5

 p. 161

06/2017 ->



**152180**

(OE 7CA 945 091)

gauche - sinistra - izquierda



AMP 1.5-7P-M

arrière  
connettore posteriore  
conector trasero



**152180**

(OE 7CA 945 092)

droit - destra - derecha





**D11868**

AMP 1.5-7P-F



**052500**

(OE 5001847153)

gauche - sinistra - izquierda





**052500**

(OE 5001847153)

droit - destra - derecha



### LC8

 p. 156

06/2006 ->  
05/2017



**156340**

(OE 2E0 945 095 A)

gauche - sinistra - izquierda



AMP 1.5-7P-M

arrière  
connettore posteriore  
conector trasero



**156350**

(OE 2E0 945 096 A)

droit - destra - derecha



**D11868**

AMP 1.5-7P-F



**056540**

(OE 2E0 945 111 A)

gauche - sinistra - izquierda





**056550**

(OE 2E0 945 112 A)

droit - destra - derecha



FH

## LC9 LED



p. 142

12/2012 -&gt;

LED

24V

**158030**

(OE 82849894 / 84195505 / 84441766 / 23354972)



gauche - sinistra - izquierda



AMP 1.5-7P-M

latéral  
connettore laterale  
conector lateral**158050**

(OE 82849923 / 84195521 / 84441768 / 23354974)



droit - destra - derecha

**158040**

(OE 82849925 / 84195519 / 84441767 / 23354973)



droit - destra - derecha

**D11868**

AMP 1.5-7P-F

**058000**

(OE 82849905)



gauche - sinistra - izquierda

**058000**

(OE 82849905)



droit - destra - derecha

## SRD08



p. 185

09/2012 -&gt;

LED

24V

**111000**

(OE 82151157)

gauche - sinistra - izquierda

**111010**

(OE 82151205)

droit - destra - derecha

**111020**

(OE 21346521)

gauche - sinistra - izquierda

**111030**

(OE 21346522)

droit - destra - derecha



FH 08/2008 -> 09/2012

**LED**

 24V



**107000**  
(OE 82114506 / 82355678 / 84139927)  
gauche - sinistra - izquierda



**107010**  
(OE 82114500 / 82355684 / 84139939)  
droit - destra - derecha



**107040**  
(OE 82114504 / 21448885)  
gauche - sinistra - izquierda



**107050**  
(OE 82114502 / 21478751)  
droit - destra - derecha



## FE08 H2

09/2012 ->

**LED**

 24V



**112010**  
(OE 82278930)   
gauche - sinistra - izquierda



**112000**  
(OE 82278938)   
droit - destra - derecha

## ID08

09/2012 ->

**LED**

 24V



**114000**  
(OE 21214534) 

**114010**  
(OE 82150539) 

**114020**  
(OE 21214524) 

FH

## FE08 H1

09/2012 -&gt;

LED

24V



**116010**  
(OE 82349220)

**116030**  
(OE 21368782)

gauche - sinistra - izquierda



**116000**  
(OE 82349221)



**116020**  
(OE 21368783)

droit - destra - derecha



**116040**  
(OE 82348508)

**116050**  
(OE 21368779)

**116060**  
(OE 21368781)



## FE07

08/2008 -&gt;

LED

24V



**207000**  
(OE 82116545)



**207010**  
(OE 21087346)



**207020**  
(OE 21087347)

## SL08

09/2012 -&gt;

5W



**113000**  
(OE 82202076)

Lampe de portière  
Luce di portiera  
Piloto de puerta

### ATLAS

 p. 252

04/2021 ->

**NEW**

**LED**

 9/32V



**212730**  
(OE 23742314)



TYCO MCON-2P-M

## FH - FM

### SH3

 p. 237

 H3/70W-24V



**D12111**  
(OE 20872890)

### SHD 1200

 p. 227

05/2014 -> 12/2015

**LED**

 9/36V



**D14161**  
(OE 84185589)

DT-2P-M



**D14170**

DT-2P-F

## FH - FM - FL

### SMD00

 p. 198

2001 ->

**LED**

 24V



**198620**  
(OE 82392733)

**K**

Cuve blanche - cabochon PMMA  
Scatola bianca - lente PMMA  
Caja blanca - tulipa PMMA



**198740**  
(OE 84044658)

**K**

Cuve ambre - cabochon PC haute température  
Scatola arancione - lente PC temperatura elevata  
Caja naranja - tulipa PC temperatura alta



**001766**  
(OE 85105029)

adaptateur - adattatore - adaptador

FM



## LC10 LED p. 143

09/2013 ->

LED

 24V





**159500**     
 (OE 82483074 / 84441759 /  
 23522307 / 23690769)  
 gauche - sinistra - izquierda





**AMP 1.5-7P-M**  
 latéral  
 connettore laterale  
 conector lateral





**159530**    
 (OE 21735299 / 84441937  
 23522305 / 23690765)  
 droit - destra - derecha



**159520**    
 (OE 21735301 / 84441936 /  
 23522304 / 23690764)  
 gauche - sinistra - izquierda



**159510**     
 (OE 82483073 / 84441760 /  
 23522308)  
 droit - destra - derecha



**D11868** **AMP 1.5-7P-F**



**059500**   
 (OE 84122332)  
 gauche - sinistra - izquierda



**059500**   
 (OE 84122332)  
 droit - destra - derecha

## SRD07 p. 185

09/2010 -> 10/2013

LED

 24V



**107000**  
 (OE 82114506 / 82355678)  
 gauche - sinistra - izquierda



**107010**  
 (OE 82114500 / 82355684)  
 droit - destra - derecha



**107040**  
 (OE 82114504 / 21448885)  
 gauche - sinistra - izquierda



**107050**  
 (OE 82114502 / 21478751)  
 droit - destra - derecha

11/2013 ->



**107500**  
 (OE 82467736)  
 gauche - sinistra - izquierda



**107510**  
 (OE 82467737)  
 droit - destra - derecha

### FE07

08/2008 ->

LED

24V



**207000**  
(OE 82116545)



**207010**  
(OE 21087346)



**207020**  
(OE 21087347)

### LC9

p. 160

01/2006 ->



**159010**  
(OE 20769775)   
gauche - sinistra - izquierda



**AMP 1.5-7P-M**  
latéral  
connettore laterale  
conector lateral



**159020**  
(OE 20769776)   
droit - destra - derecha



**159030**  
(OE 20769777)   
droit - destra - derecha



**D11868** **AMP 1.5-7P-F**



**059000**  
(OE 20802418)   
gauche - sinistra - izquierda



**059000**  
(OE 20802418)   
droit - destra - derecha



**D12953**

## FL - FE

### LC5

 p. 161

2006 ->



**152190**  
(OE 20769783)

gauche - sinistra - izquierda





AMP 1.5-7P-M

arrière  
connettore posteriore  
conector trasero



**152200**  
(OE 20769784)

droit - destra - derecha



**152880**  
(OE 20769781)

gauche - sinistra - izquierda





**152880**  
(OE 20769782)

droit - destra - derecha





**D11868** AMP 1.5-7P-F



**052000**  
(OE 20537280)

**052500**  
(OE 20745060)

gauche - sinistra - izquierda





**052000**  
(OE 20537280)

**052500**  
(OE 20745060)

droit - destra - derecha



## ICDL94

 p. 187



**119550**  
(OE 21341202)

JPT-3P-M



**001616**  
(OE 20745227)



**D13877** JPT-3P-F

## FE95

 p. 193



**195010**  
(OE 20745225)

gauche - sinistra - izquierda



**195010**  
(OE 20745225)

droit - destra - derecha

## FL - FE

### SH3

 p. 237

- \* Lampe fournie
- \* Con lampada
- \* Lámpara incluida



**D13019\***  
(OE 21396991)

**DT-2P-M**



**D14170**

**DT-2P-F**

## FL

### EPP98

 p. 181



**196010**  
(OE 20721495)

**JPT-2P-M**



**D13876**

**JPT-2P-F**

### FE02

 p. 193

2006 ->



**102200**  
(OE 20717520)

**K**

Clippé - fissaggio con clip - fijación con clip

**JPT-2P-M**



**001726**

(OE 20745066)



**D13876**

**JPT-2P-F**

### FPL93

 p. 200



**193020**  
(OE 20734485 / 84538758)

**K**

**JPT-2P-M**



**001726**

(OE 20745066)



**D13876**

**JPT-2P-F**

## SMD98

i | p.197

LED

⚡ 24V

-> 2003



**198650**  
(OE 20480486)

K

JPT-2P-M



**D13876**

JPT-2P-F

## SMD98

i | p.203

LED

⚡ 24V

-> 2003



**198640**  
(OE 70364301)

K

JPT-2P-M



**D13876**

JPT-2P-F



# VOLVO CONSTRUCTION

## SMD98

 p.197

**LED**

 24V



**198520**  
(OE 11170068)

**K**

**JPT-2P-M**



**D13876**

**JPT-2P-F**

## CHL1H4

 p.243

 24V  
H4 - PY21 - W5W



**D14320** 12V

**D14322** 24V

gauche - sinistra - izquierda



**DT-6P-M**

arrière  
connettore posteriore  
conector trasero



**D14321** 12V

**D14323** 24V

droit - destra - derecha



**D14352**

**DT-6P-F**

## TRI

 p.217



**D10596**  
(OE 23374865)

**K**

# Feux arriere

## Fanali posteriori

### Pilotos traseros

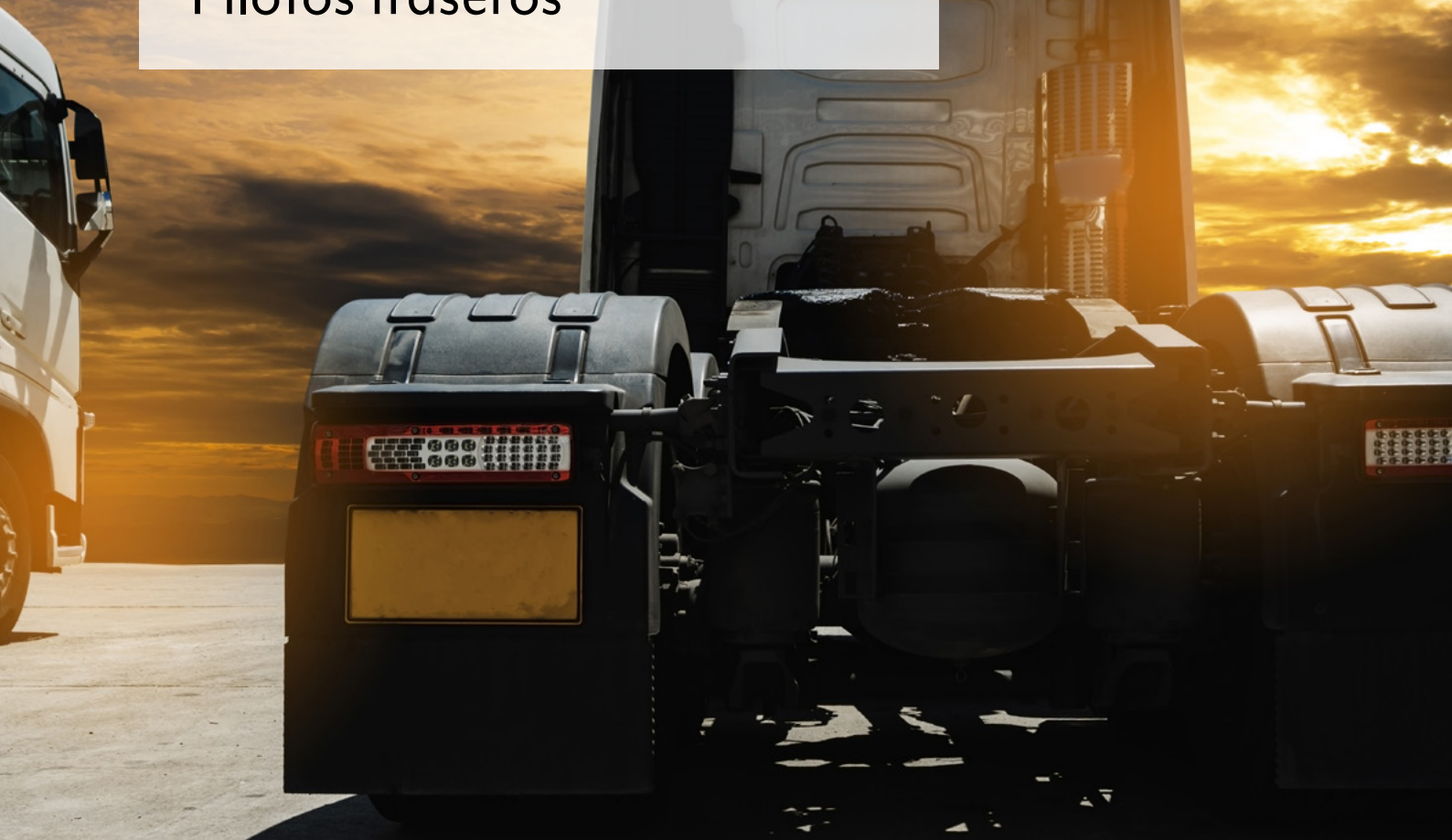

## LED

p. 138-149



**NEW**

## Halogene

p. 150-177



**K** Catadioptr  
Catarifrangente  
Catadióptrico

**T** Catadioptr triangulaire  
Triangolo carifrangente  
Catadióptrico triangular

**FPL** Feu de position latéral  
Luce di posizione laterale  
Piloto de posición lateral

**EPP** Eclaireur de plaque  
Luce targa  
Iluminación de placa

**Alar** Alarme sonore de recul  
Cicalino di ritromarcia  
Alarma sonora de marcha atrás

**Con** Connecteurs additionnels  
Connettori addizionali  
Conectores adicionales

**AMP 1.5-7P-M**



Type connecteur - Nb pins - Mâle ou Femelle  
Tipo di connettore - Num pin - Maschio o Femmina  
Tipo de conector - Num pines - macho o hembra

Flashez le QR code pour plus d'infos  
Scansiona il codice QR per maggiori informazioni  
Escanee el código QR para obtener más info

Pièces détachées  
Ricambi  
Repuestos

Numéro d'homologation  
Número di omologazione  
Número de aprobación

Sens de montage  
Direzione di montaggio  
Dirección de montaje



Faisceau p. 307  
Cablaggio p. 307  
Cableado p. 307

DETAIL CONNECTEUR 1.5	Support des Pinces Cableage	FUNCTION
1	STOP	STOP
2	POSITION	POSITION
3	REDA	REDA
4	INDICATEUR DE DIRECTION	INDICATOR
5	STOP	STOP
6	REDA	REDA
7	NOT USED	

Pinning connecteurs sur notre site web  
Pinning dei connettori sul nostro sito web  
Pinning conectores en nuestro sitio web

# Feux arriere - Fanali posteriori - Pilotos traseros

## LC12 LED

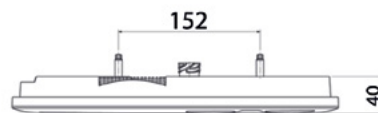
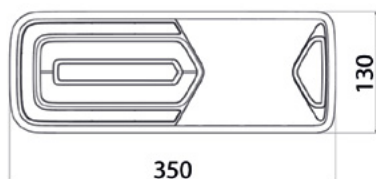

**ORIGINAL**



**LED**

**ADR**



E<sub>2</sub> 16027  
10R-0516057

Affectations constructeurs  
Applicazione primo impianto  
Afectación primer equipo

ASCA p. 8  
BENALU p. 12  
DE BUF p. 28  
FELDBINDER p. 32  
FRUEHAUF p. 35  
GUILLEN p. 37  
LAMBERET p. 61  
MAGYAR p. 69  
OMEPS p. 82  
SCHMITZ p. 117  
SOR IBERICA p. 119



**161000** 24V

**161200** 12V

gauche - sinistra - izquierda



AMP 1.5-7P-M

arrière  
connettore posteriore  
conector trasero



**161010** 24V

**161210** 12V

droit - destra - derecha



**161120** 24V

**161260** 24V

**161190** 24V

gauche - sinistra - izquierda



**161130** 24V

**161270** 24V

**161180** 24V

droit - destra - derecha

**GLOWING**



**LED**

**ADR**



E<sub>2</sub> 18042  
10R-0516057



**161280** 24V

**161420** 12V

gauche - sinistra - izquierda



AMP 1.5-7P-M

arrière  
connettore posteriore  
conector trasero



**161290** 24V

**161430** 12V

droit - destra - derecha



**161500** 24V

**161560** 24V

**161460** 24V

gauche - sinistra - izquierda



**161510** 24V

**161570** 24V

**161470** 24V

droit - destra - derecha



ORIGINAL



GLOWING



Clignotant dynamique  
Dynamic indicator  
Intermitente dinámico



4 connecteurs pour options  
4 conettori per le opzioni  
4 conectores para opciones

Resistance integree (contrôle défaillance indicateur)  
Resistenza integrata (controllo errore intermittente)  
Resistencia integrada (control de fallo del intermitente)

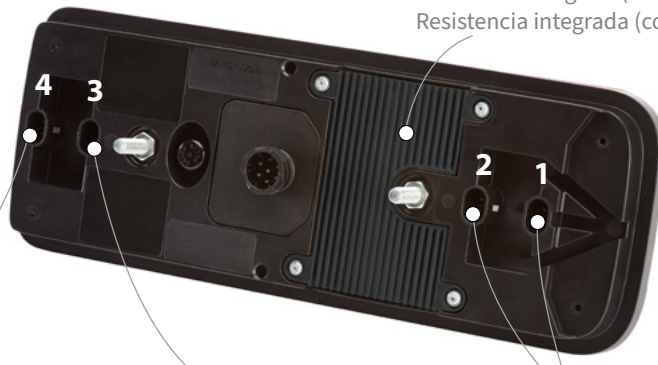

1+2+4 = 1 Amp maxi  
3 = 1 Amp maxi

Position lateral clignotant  
Posizione laterale lampeggiante  
Posición lateral e intermitente



Recul  
Ritromarcia  
Marcha Atrás



Position  
Posizione  
Posición



CLICK-IN

104090

500 mm



104100

1500 mm



D14857

DT-2P-M



SS-2P-F

R14364

2000 mm



D11868

AMP 1.5-7P-F



SS-2P-F

R14412

16 m



DT-2P-F

SS-2P-F

R14413

1500 mm



SS-2P-F

D14781

gauche - sinistra - izquierda



SS-2P-F

D14782

droit - destra - derecha



SS-2P-M

R14426

1500 mm

Rallonge SUPERSEAL 2 voies  
Prolunga SUPERSEAL 2 vie  
Alargador SUPERSEAL 2 vías

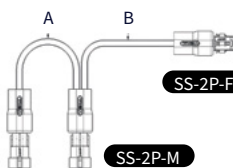

SS-2P-F

SS-2P-M

R14418

A: 300 mm / B: 500 mm



SS-2P-F

D14425

1500 mm

gauche - sinistra - izquierda



SS-2P-F

D14426

1500 mm

droit - destra - derecha

# Feux arriere - Fanali posteriori - Pilotos traseros

## LC11

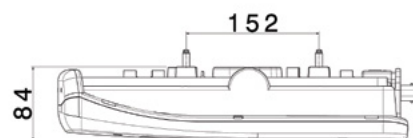
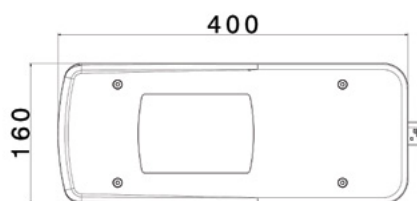

LED

24V

ADR

H

14085  
E2 14086 -FPL  
10R-047585

Affectations constructeurs  
Applicazione primo impianto  
Afectación primer equipo

IVECO p. 43



**160150**

gauche - sinistra - izquierda

K FPL



HDSCS-8P-M

latéral  
connettore laterale  
conector lateral



**160100**

droit - destra - derecha

K FPL



**160080**

gauche - sinistra - izquierda

K FPL EPP



**160090**

droit - destra - derecha

K FPL



**160110**

gauche - sinistra - izquierda

K FPL



HDSCS-8P-M

arrière  
connettore posteriore  
conector trasero



**160130**

droit - destra - derecha

K FPL



**160140**

gauche - sinistra - izquierda

K FPL EPP



**160120**

droit - destra - derecha

K FPL



**D13878**

HDSCS-8P-F



**060000**

gauche - sinistra - izquierda

K



**060010**

droit - destra - derecha

K

# Feux arriere - Fanali posteriori - Pilotos traseros

## LC11

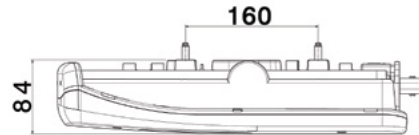
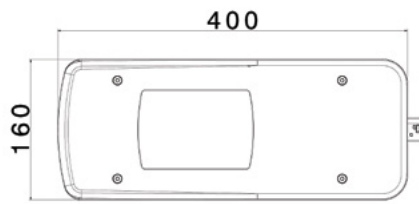

LED

12V

ADR

H

E2 14085  
14086 - FPL  
10R-047585

Affectations constructeurs  
Applicazione primo impianto  
Afectación primer equipo

MERCEDES p. 77



**160400**

gauche - sinistra - izquierda

K FPL EPP



AMP 1.5-7P-M

arrière  
connettore posteriore  
conector trasero



**160410**

droit - destra - derecha

K FPL



**D11868**

AMP 1.5-7P-F



**060000**

gauche - sinistra - izquierda

K



**060010**

droit - destra - derecha

K



# Feux arriere - Fanali posteriori - Pilotos traseros

## LC9 LED

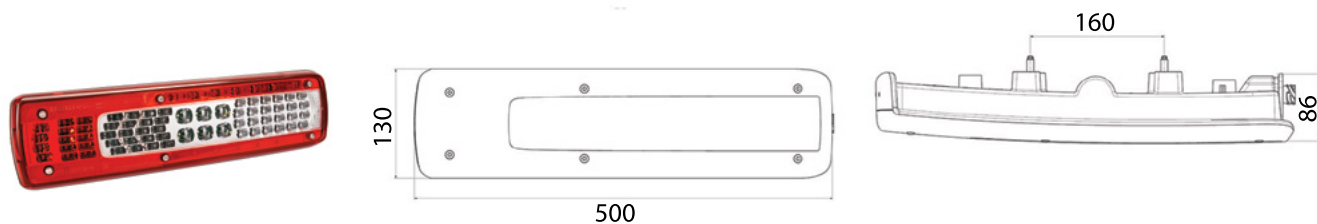

LED

24V



E2 10113  
10R-036227

Affectations constructeurs  
Applicazione primo impianto  
Afectación primer equipo

RENAULT TRUCKS p. 86  
VOLVO TRUCKS p. 127



**158030**

gauche - sinistra - izquierda



AMP 1.5-7P-M

latéral  
connettore laterale  
conector lateral



**158050**

droit - destra - derecha



**158040**

droit - destra - derecha



**D11868**

AMP 1.5-7P-F



**058000**

gauche - sinistra - izquierda



**058000**

droit - destra - derecha



## LC10 LED

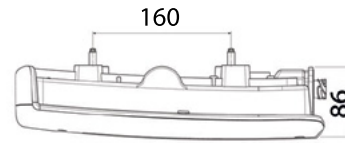

LED

24V



E2 12164  
10R-036854

Affectations constructeurs  
Applicazione primo impianto  
Afectación primer equipo

RENAULT TRUCKS p. 87  
VOLVO TRUCKS p. 131



**159520**

gauche - sinistra - izquierda



AMP 1.5-7P-M

latéral  
connettore laterale  
conector lateral



**159530**

droit - destra - derecha



**159500**

gauche - sinistra - izquierda



**159510**

droit - destra - derecha



**D11868** AMP 1.5-7P-F



**059500**

gauche - sinistra - izquierda



**059500**

droit - destra - derecha



# Feux arriere - Fanali posteriori - Pilotos traseros

## CTL15



LED

24V

1200 Lumen



E<sub>2</sub> 16005

Affectations constructeurs  
Applicazione primo impianto  
Afectación primer equipo

CHEREAU p. 19  
LECAPITAINE p. 65  
TROUILLET p. 123

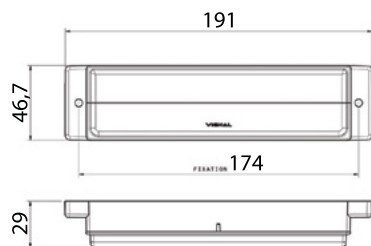

DT04-4P-M



Fixation par l'arrière  
Fissaggio posteriore  
Fijación trasera

**164000**

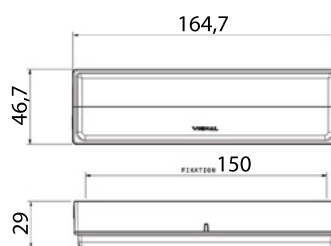

DT04-4P-M



DTM04-4P-M



**164010**

Pour raccordement sur feu BL15  
Per collegamento su fanale BL15  
Para conectar sobre piloto BL15



DT04-4P-M



Fixation par l'avant  
Fissaggio frontale  
Fijación frontal

**164020**



DT04-4P-M



DTM04-4P-M



**164030**

Pour raccordement sur feu BL15  
Per collegamento su fanale BL15  
Para conectar sobre piloto BL15

## BL15



LED

24V



E<sub>2</sub> 16007  
10R-0516079

Affectations constructeurs  
Applicazione primo impianto  
Afectación primer equipo

CHEREAU p. 19  
FRUEHAUF p. 35  
LECAPITAINE p. 65  
TROUILLET p. 123

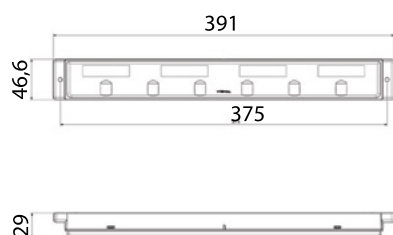

**165020**

gauche - sinistra - izquierda



DT04-4P-M



DTM06-4S-4P-F

Fixation par l'arrière  
Fissaggio posteriore  
Fijación trasera



**165040**

gauche - sinistra - izquierda

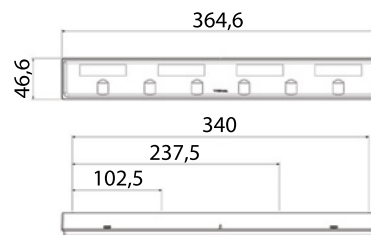

**165030**

droit - destra - derecha



**165050**

droit - destra - derecha

# Feux arriere - Fanali posteriori - Pilotos traseros

## CTL15 - BL15



Indicateur de direction à défilement - feux de détresse flash  
 Indicatore di direzione dinamico - luci di emergenza flash  
 Intermitentes dinámicos - luces de emergencia flash



Feu de travail 1200 Lumen  
 Faro da lavoro 1200 Lumen  
 Faro de trabajo 1200 Lumen

Stop et position  
 Stop e posizione  
 Stop y posición



## CTL15 - BL15

- LED**
- 24V**
- 1200 Lumen**
- H**
- E2** 16005  
16007  
10R-0516079

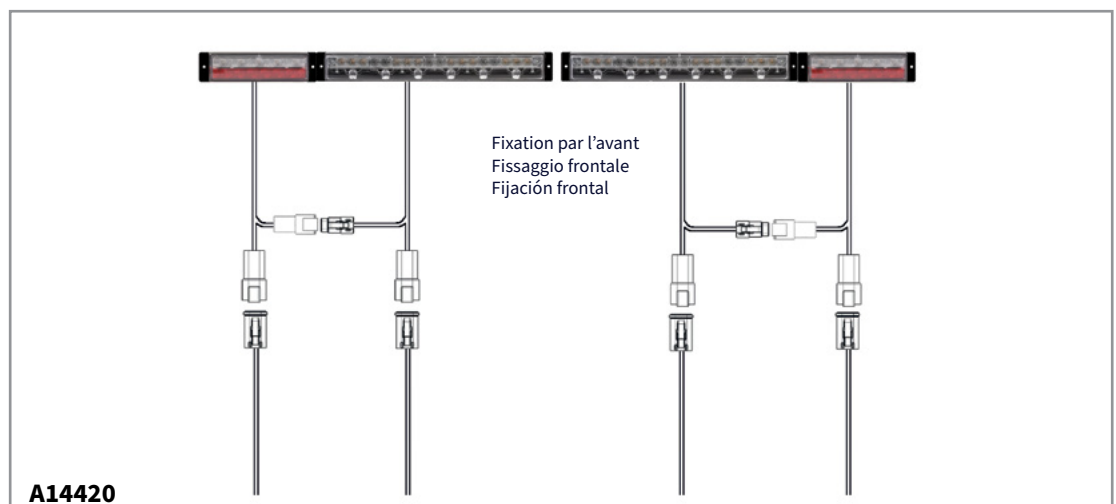

**A14420**  
 2 x CTL15 + 1 x BL15 gauche + 1 x BL15 droit + 4 câbles 8,5 m  
 2 x CTL15 + 1 x BL15 sinistro + 1 x BL15 destro + 4 cavi 8,5 m  
 2 x CTL15 + 1 x BL15 izquierdo + 1 x BL15 derecho + 4 cables 8,5 m

# Feux arriere - Fanali posteriori - Pilotos traseros

## LCR19

**GLOWING**

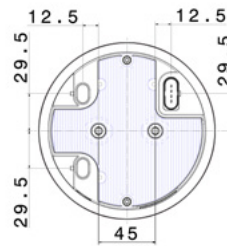
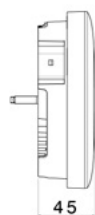
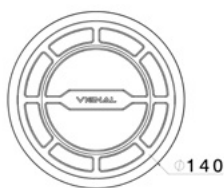

**NEW**

**LED**

**24V**

**H**

**E<sub>2</sub> 19106**

Affectations constructeurs  
Applicazione primo impianto  
Afectación primer equipo

SCHMITZ p. 117



**213010**

**AMP MCP-4P-M**

Position Glowing - Stop - Clignotant  
Posizione Glowing - Stop - Indicatore  
Posición Glowing - Stop - Intermitente



**213070**

**AMP MCP-4P-M**

Position Glowing - Stop - Clignotant  
Posizione Glowing - Stop - Indicatore  
Posición Glowing - Stop - Intermitente



**213090**

**AMP MCP-4P-M**

Position Glowing - Stop - Clignotant  
Posizione Glowing - Stop - Indicatore  
Posición Glowing - Stop - Intermitente

**RI**

**SMC**

**POS**

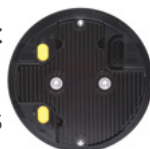

**POS**

**POS**



**CE** Connecteurs additionnels Superseal 2 voies mâle  
Connettori addizionali Superseal 2 vie maschio  
Conectores adicionales Superseal 2 vias macho

**NEW**

**R23**



**213150**

**AMP MCP-4P-M**

Recul - Brouillard  
Ritromarcia - Retronebbia  
Marcha atrás - Antiniebla



**213160**

**AMP MCP-4P-M**

Recul - Brouillard  
Ritromarcia - Retronebbia  
Marcha atrás - Antiniebla



**213200**

**AMP MCP-4P-M**

Position Glowing - Recul - Brouillard  
Posizione Glowing - Ritromarcia - Retronebbia  
Posición Glowing - Marcha atrás - Antiniebla



**002100**

Anneau chromé  
Anello cromato  
Anillo cromado

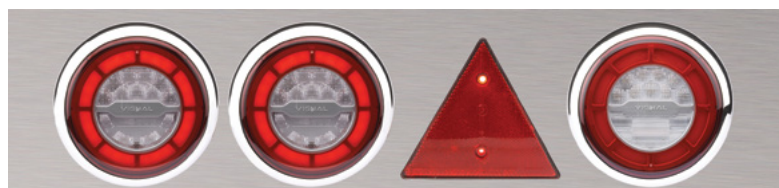

\* **SMC**  
Position lateral clignotant  
Posizione laterale lampeggiante  
Posición lateral e intermitente

**POS**  
Position  
Posizione  
Posición

**R23**  
Recul  
Ritromarcia  
Marcha Atrás

**RI**  
Resistance integree (contrôle défaillance indicateur)  
Resistenza integrata (controllo errore intermittente)  
Resistencia integrada (control de fallo del intermitente)

# Feux arriere - Fanali posteriori - Pilotos traseros

## LCR19

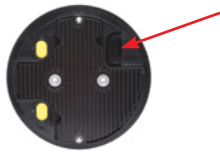

	<b>D14984</b>	<b>AMP-MCP-4P-F</b>	<b>D14980</b>	<b>D14983</b>
			<b>AMP 1.5-7P-M</b>	<b>AMP-MCP-4P-F</b>

<b>D14846</b>	<b>D14847</b>	<b>D14884</b>	<b>D14885</b>
<b>HDSCS-6P-F</b>	<b>HDSCS-6P-F</b>	<b>HDSCS-6P-F</b>	<b>HDSCS-6P-F</b>
gauche - sinistra - izquierda	droit - destra - derecha	gauche - sinistra - izquierda	droit - destra - derecha

Affectations constructeurs  
Applicazione primo impianto  
Afectación primer equipo

SCHMITZ p. 117

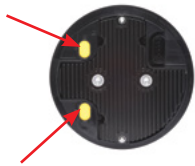

<b>SMC</b>		<b>POS</b>		<b>POS</b>		<b>POS</b>	
	<b>CLICK-IN</b>		<b>SS-2P-F</b>		<b>SS-2P-F</b>		<b>SS-2P-F</b>
<b>104090</b>	500 mm <b>K</b>	<b>R14364</b>	2000 mm	<b>D14425</b>	1500 mm	<b>D14426</b>	1500 mm
<b>104100</b>	1500 mm <b>K</b>			gauche - sinistra - izquierda		droit - destra - derecha	

<b>R14412</b>	<b>R14426</b>	<b>R14418</b>
16 m	1500 mm	A: 300 mm/ B: 500 mm

Rallonge SUPERSEAL 2 voies  
Prolunga SUPERSEAL 2 vie  
Alargador SUPERSEAL 2 vías

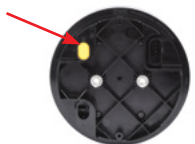

<b>R23</b>	<b>DT-2P-F</b>
<b>D14857</b>	<b>R14413</b>
<b>DT-2P-M</b>	1500 mm
	<b>SS-2P-F</b>

\* **SMC**  
Position lateral clignotant  
Posizione laterale lampeggiante  
Posición lateral e intermitente

**POS**  
Position  
Posizione  
Posición

**R23**  
Recul  
Ritromarcia  
Marcha Atrás

**RI**  
Resistance integree (contrôle défailance indicateur)  
Resistenza integrata (controllo errore intermittente)  
Resistencia integrada (control de fallo del intermitente)

# Feux arriere - Fanali posteriori - Pilotos traseros

## CTL14

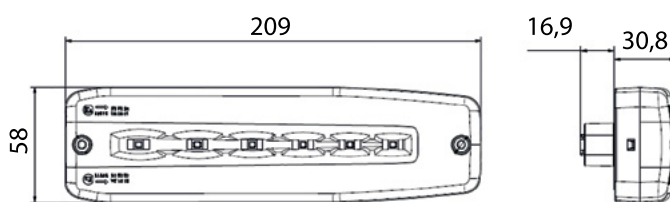

LED

12/24V



E2 16111  
10R-17254



**DT04-4P-M**  
arrière  
connettore posteriore  
conector trasero



**D14436** DT06-4S-4P-F

**163010**

gauche/droit - sinistra/destra - izquierda/derecha



Stop - position - clignotant dynamique  
Stop - posizione - indicatore di direzione dinamico  
Stop - posición - intermitente dinámico



## SLIM

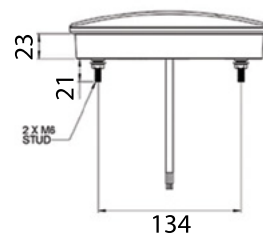
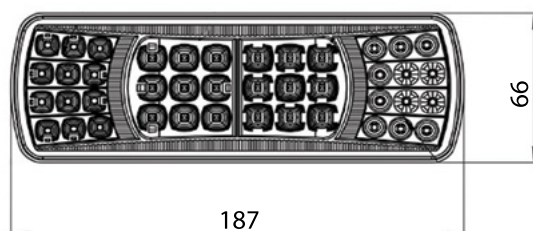

LED

12/24V



E9 11734  
10R-051614

\* fils nus - estremoità cavo  
nuda - cable pelado



5 FONCTIONS - FUNZIONI - FUNCIONES

**D13817\***

gauche/droit - sinistra/destra - izquierda/derecha



Stop - position - clignotant - recul - antibrouillard  
Stop - posizione - indicatore di direzione - retromarcia - antinebbia  
Stop - posición - intermitente - marcha atrás - antiniebla



# Feux arriere - Fanali posteriori - Pilotos traseros

## FRR



LED

12/24V



13992  
E4 23271  
4052



\* cosses plates - connettori a spina piatta - vainas planas

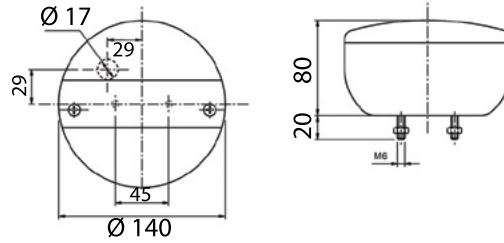

**D13816 \***  
gauche/droit - sinistra/destra - izquierda/derecha



**D14189 \***  
feu de recul  
luce di retromarcia  
piloto marcha atrás



**D14188 \***  
feu de brouillard  
luce retronebbia  
piloto antiniebla



Stop - position - clignotant  
Stop - posizione - indicatore di direzione  
Stop - posición - intermitente

## FRR



LED

12/24V



6653  
E9 1288  
10R-041489  
10R-041487



\* fils nus - estremità cavo nuda - cable pelado

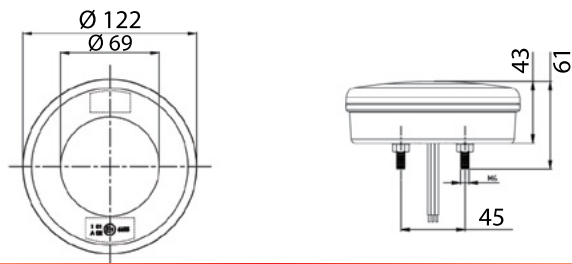

**D14348\***  
gauche/droit - sinistra/destra - izquierda/derecha



**D14345\***  
feu de recul - brouillard  
luce di retromarcia - retronebbia  
piloto marcha atrás - antiniebla



Stop - position - clignotant  
Stop - posizione - indicatore di direzione  
Stop - posición - intermitente

# Feux arriere - Fanali posteriori - Pilotos traseros

## LC8

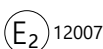
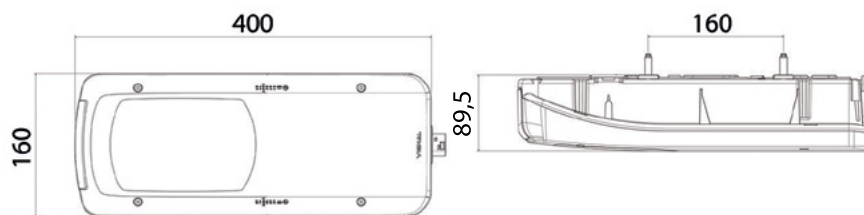

Affectations constructeurs  
Applicazione primo impianto  
Afectación primer equipo

DAF p. 23



**155100**



gauche - sinistra - izquierda



**HDSCS-8P-M**

latéral  
connettore laterale  
conector lateral



**155110**



droit - destra - derecha



**155120**



droit - destra - derecha



**155130**



gauche - sinistra - izquierda



**HDSCS-8P-M**

arrière  
connettore posteriore  
conector trasero



**155140**



droit - destra - derecha



**155150**



droit - destra - derecha



**D13878**

**HDSCS-8P-F**



**055020**



gauche - sinistra - izquierda



**055030**



droit - destra - derecha



**001830**



# Feux arriere - Fanali posteriori - Pilotos traseros

## LC8

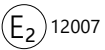
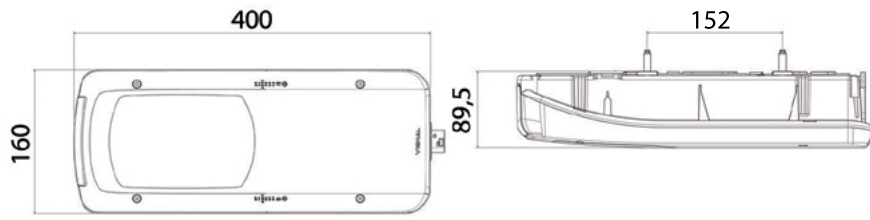

Affectations constructeurs  
Applicazione primo impianto  
Afectación primer equipo

VOLKSWAGEN p. 126



**155570**

gauche - sinistra - izquierda



**AMP 1.5-7P-M**

arrière  
connettore posteriore  
conector trasero



**155580**

droit - destra - derecha



**D11868**

**AMP 1.5-7P-F**



**055020**

gauche - sinistra - izquierda



**055030**

droit - destra - derecha





# Feux arriere - Fanali posteriori - Pilotos traseros

## LC8

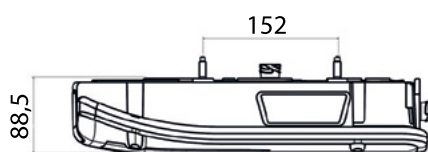
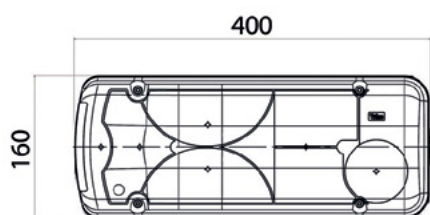

Affectations constructeurs  
Applicazione primo impianto  
Afectación primer equipo  
IVECO p. 44

DESIGN EFFET FUMÉ - MÉTALLISÉ  
DESIGN METALLIZZATO - FUMATO  
DISEÑO EFECTO AHUMADO - METALIZADO



**155450**

gauche - sinistra - izquierda



HDSCS-8P-M

latéral  
connettore laterale  
conector lateral



**155460**

droit - destra - derecha



**155470**

droit - destra - derecha



**155480**

gauche - sinistra - izquierda



HDSCS-8P-M

arrière  
connettore posteriore  
conector trasero



**155490**

droit - destra - derecha



**155540**

gauche - sinistra - izquierda



**155500**

droit - destra - derecha



**D13878**

HDSCS-8P-F



**055040**

gauche - sinistra - izquierda



**055050**

droit - destra - derecha



**001830**



# Feux arriere - Fanali posteriori - Pilotos traseros

## LC8

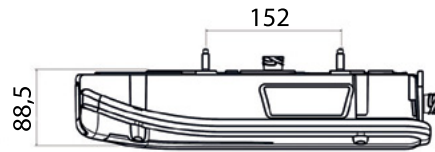
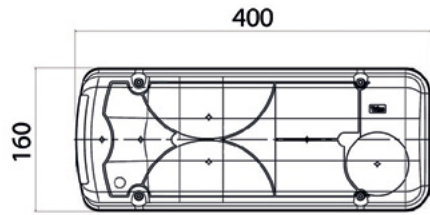

Affectations constructeurs  
Applicazione primo impianto  
Afectación primer equipo

MAN p. 70



**156200** K FPL EPP  
gauche - sinistra - izquierda



**AMP 1.5-7P-M**  
latéral  
connettore laterale  
conector lateral

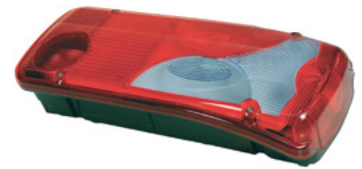

**156210** K FPL  
droit - destra - derecha



**001872** 55-90 db



**156220** K FPL   
droit - destra - derecha

Affectations constructeurs  
Applicazione primo impianto  
Afectación primer equipo

MAN (TGE) p. 71

\* vis arrière de 31 mm  
\* viti posteriori di 31 mm  
\* tornillos traseros de 31 mm



**155550** \* 12V K FPL  
gauche - sinistra - izquierda



**AMP 1.5-7P-M**  
arrière  
connettore posteriore  
conector trasero

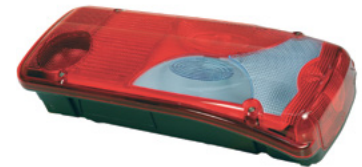

**155560** \* 12V K FPL  
droit - destra - derecha



**D11868** **AMP 1.5-7P-F**

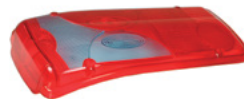

**056500** K  
gauche - sinistra - izquierda



**056510** K  
droit - destra - derecha

# Feux arriere - Fanali posteriori - Pilotos traseros

## LC8

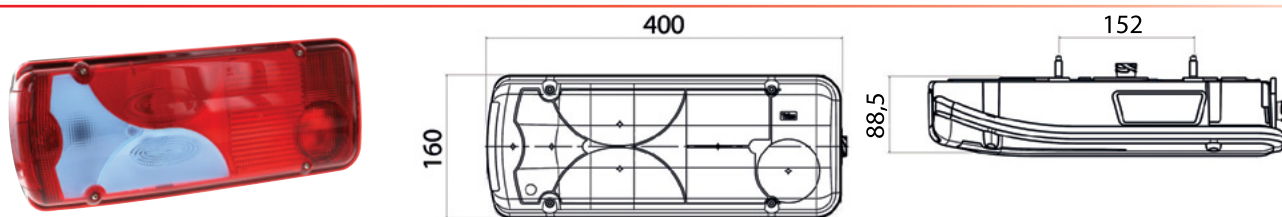

ADR



E<sub>2</sub> 2040

Affectations constructeurs  
Applicazione primo impianto  
Afectación primer equipo

CHEREAU p. 20  
LAMBERET p. 62



**156550**

gauche - sinistra - izquierda

FPL



AMP 1.5-7P-M

arrière  
connettore posteriore  
conector trasero

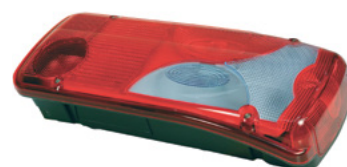

**156540**

droit - destra - derecha

FPL



**156310**

gauche - sinistra - izquierda

K FPL

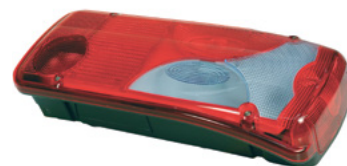

**156300**

droit - destra - derecha

K FPL



**156290**

gauche - sinistra - izquierda

K FPL EPP



**D11868**

AMP 1.5-7P-F

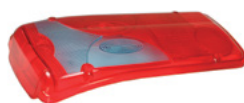

**056000**

**056500**

gauche - sinistra - izquierda

K



**056010**

**056510**

droit - destra - derecha

K

# Feux arriere - Fanali posteriori - Pilotos traseros

## LC8

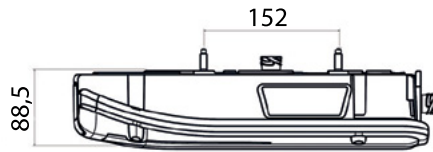
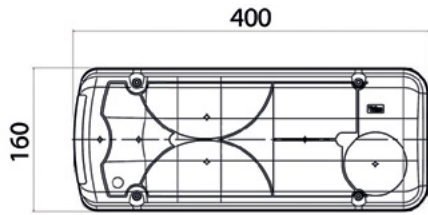

Affectations constructeurs  
Applicazione primo impianto  
Afectación primer equipo

SCANIA p. 115



**156770** K FPL EPP  
gauche - sinistra - izquierda



**AMP 1.5-7P-M**  
latéral  
connettore laterale  
conector lateral



**156780** K FPL  
droit - destra - derecha



**155020** K FPL  
gauche - sinistra - izquierda



**156790** K FPL Speaker  
droit - destra - derecha



**155080** K FPL EPP  
gauche - sinistra - izquierda



**AMP 1.5-7P-M**  
arrière  
connettore posteriore  
conector trasero



**155520** K FPL  
droit - destra - derecha



**155090** K FPL Speaker  
droit - destra - derecha



**D11868** **AMP 1.5-7P-F**



**056540** K  
gauche - sinistra - izquierda



**056550** K  
droit - destra - derecha



**001830** Speaker

# Feux arriere - Fanali posteriori - Pilotos traseros

## LC8

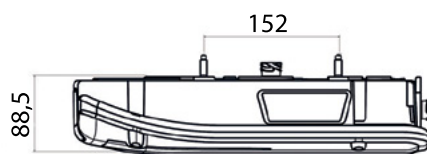
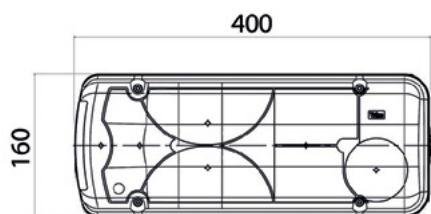

Affectations constructeurs  
Applicazione primo impianto  
Afectación primer equipo

MERCEDES p. 77  
VOLKSWAGEN p. 126



**156590**

gauche - sinistra - izquierda



AMP 1.5-7P-M

arrière  
connettore posteriore  
conector trasero



**156600**

droit - destra - derecha



**156340**

gauche - sinistra - izquierda



**156350**

droit - destra - derecha



**D11868**

AMP 1.5-7P-F



**056020**

**056540**

gauche - sinistra - izquierda



**056030**

**056550**

droit - destra - derecha



# Feux arriere - Fanali posteriori - Pilotos traseros

## LC8T

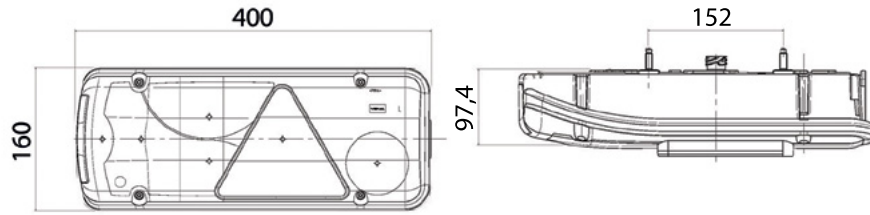

Affectations constructeurs  
Applicazione primo impianto  
Afectación primer equipo

ASCA p. 8  
BENALU p. 12  
CHEREAU p. 20  
FRUEHAUF p. 35  
GUILLEN p. 37  
LAMBERET p. 61  
SOR IBERICA p. 119



**156040**   
gauche - sinistra - izquierda



**AMP 1.5-7P-M**  
arrière  
connettore posteriore  
conector trasero



**156050**   
droit - destra - derecha



**156060**   
gauche - sinistra - izquierda



**156070**   
droit - destra - derecha



**156130**   
droit - destra - derecha



**156630**   
gauche - sinistra - izquierda



**AMP 1.5-7P-M**  
latéral  
connettore laterale  
conector lateral



**156640**   
droit - destra - derecha



**Repiquage fonctions stop et positions**  
**Collegamento funzioni stop e posizioni**  
**Empalme funciones stop y posición**

**Pour - Per - Para :**  
156040 - 156050 - 156060 - 156070 - 156130 - 156170 - 156250 - 156260 - 156290 - 156300 - 156310 - 156380 -  
156390 - 156540 - 156550 - 156590 - 156600

**Câblage - Cablaggio - Cableado p. 300**

# Feux arriere - Fanali posteriori - Pilotos traseros

## LC8



Affectations constructeurs  
Applicazione primo impianto  
Afectación primer equipo

- ASCA p. 8
- BENALU p. 12
- CHEREAU p. 20
- FRUEHAUF p. 35
- GUILLEN p. 37
- LAMBERET p. 61
- SOR IBERICA p. 119



**D11868** AMP 1.5-7P-F



**056700**

gauche - sinistra - izquierda



**056710**

droit - destra - derecha



**001830**



**001846**

cales - distanziatori - espaciadores

**LED**



12/24V



**D14038** 500 mm

gauche - sinistra - izquierda



**D14037** 500 mm

droit - destra - derecha



**D14039** 350 mm

gauche - sinistra - izquierda



**D14040** 350 mm

droit - destra - derecha



W5W



12/24V



**D13034** 500 mm

gauche - sinistra - izquierda



**D13035** 500 mm

droit - destra - derecha



**D12712** 350 mm

gauche - sinistra - izquierda



**D12711** 350 mm

droit - destra - derecha

## LC8T

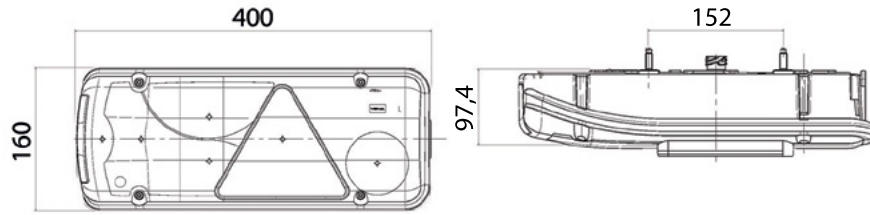

Affectations constructeurs  
Applicazione primo impianto  
Afectación primer equipo

FELDBINDER p. 32  
LECIÑENA p. 66



**156250**

gauche - sinistra - izquierda



AMP 1.5-7P-M

arrière  
connettore posteriore  
conector trasero



**156260**

droit - destra - derecha



**156380**

gauche - sinistra - izquierda



**156390**

droit - destra - derecha



**D11868**

AMP 1.5-7P-F



**056720**

gauche - sinistra - izquierda



**056730**

droit - destra - derecha





# Feux arriere - Fanali posteriori - Pilotos traseros

## LC9

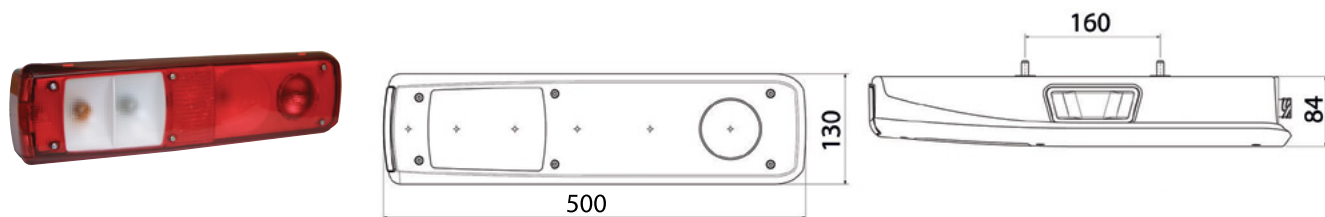

E2 04075

Affectations constructeurs  
Applicazione primo impianto  
Afectación primer equipo

RENAULT TRUCKS p. 87  
VOLVO TRUCKS p. 132



**159010**

gauche - sinistra - izquierda



AMP 1.5-7P-M

latéral  
connettore laterale  
conector lateral



**159020**

droit - destra - derecha



**159030**

droit - destra - derecha



**D11868**

AMP 1.5-7P-F



**059000**

gauche - sinistra - izquierda



**059000**

droit - destra - derecha



**D12953**



# Feux arriere - Fanali posteriori - Pilotos traseros

## LC5

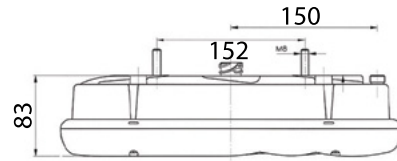
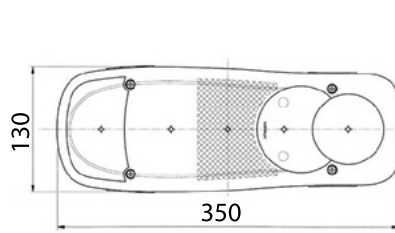

E<sub>2</sub> 8005

Affectations constructeurs  
Applicazione primo impianto  
Afectación primer equipo

BOBCAT p. 15  
DAF p. 25  
IVECO p. 49  
MANITOU p. 73  
MANITOWOC p. 75  
NISSAN p. 81  
OPEL p. 84  
RENAULT TRUCKS p. 99  
VOLKSWAGEN p. 126  
VOLVO TRUCKS p. 133



**152130**

**152150**

gauche - sinistra - izquierda



PG 13

arrière  
connettore posteriore  
conector trasero



**152130**

**152150**

droit - destra - derecha



**152160**

**152140**

gauche - sinistra - izquierda



AMP 1.5-7P-M

arrière  
connettore posteriore  
conector trasero



**152200**

**152180**

droit - destra - derecha



**152190**

**152170**

gauche - sinistra - izquierda

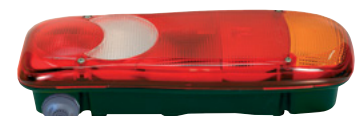

**153120**

droit - destra - derecha



**D11868**

AMP 1.5-7P-F



**052000**

**052500**

gauche - sinistra - izquierda



**052000**

**052500**

droit - destra - derecha



**D13288**

grille de protection réversible  
homologuée - Griglia approvata -  
Rejilla homologada

# Feux arriere - Fanali posteriori - Pilotos traseros

## LC5

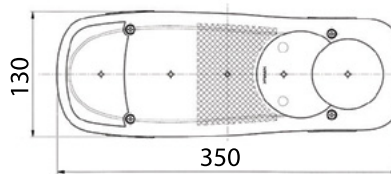

E<sub>2</sub> 8005

Affectations constructeurs  
Applicazione primo impianto  
Afectación primer equipo

FIAT p. 34  
PEUGEOT CITROËN p. 85



Fixation 4 vis M6 (190x60mm)  
Fijación 4 tornillos M6 (190x60mm)  
4 vite di fissaggio M6 (190x60mm)



**153270**

gauche - sinistra - izquierda



AMP 1.5-7P-M

arrière  
connettore posteriore  
conector trasero



**153280**

droit - destra - derecha



**D11868**

AMP 1.5-7P-F



**052500**

gauche - sinistra - izquierda



**052500**

droit - destra - derecha



# Feux arriere - Fanali posteriori - Pilotos traseros

## LC5

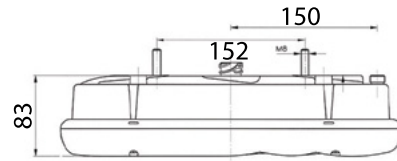
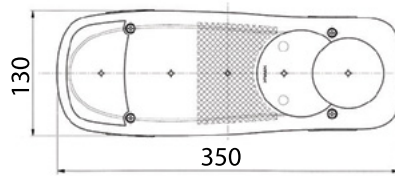

Affectations constructeurs  
Applicazione primo impianto  
Afectación primer equipo

IVECO p. 45



**153220**

gauche - sinistra - izquierda



AMP 1.5-7P-M

arrière  
connettore posteriore  
conector trasero



**153210**

droit - destra - derecha



**153200**

gauche - sinistra - izquierda



**153230**

droit - destra - derecha



**153240**

gauche - sinistra - izquierda



**153250**

droit - destra - derecha



**D11868**

AMP 1.5-7P-F



**052500**

gauche - sinistra - izquierda



**052500**

droit - destra - derecha



# Feux arriere - Fanali posteriori - Pilotos traseros

## LC5T

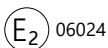
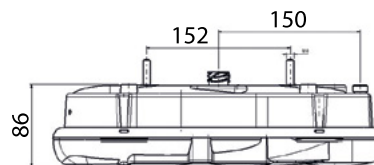
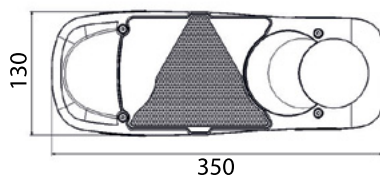

Affectations constructeurs  
Applicazione primo impianto  
Afectación primer equipo

ASCA p. 9  
LAMBERET p. 62  
LECIÑENA p. 66



**153040**

gauche - sinistra - izquierda



PG 13

arrière  
connettore posteriore  
conector trasero



**153050**

droit - destra - derecha



**153060**

gauche - sinistra - izquierda



**153070**

droit - destra - derecha



**153000**

gauche - sinistra - izquierda



AMP 1.5-7P-M

arrière  
connettore posteriore  
conector trasero



**153010**

droit - destra - derecha



**153130**



**153020**

gauche - sinistra - izquierda



**153030**

droit - destra - derecha



**D11868**

AMP 1.5-7P-F

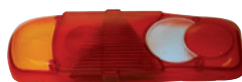

**053700**

gauche - sinistra - izquierda

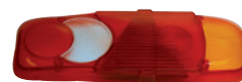

**053710**

droit - destra - derecha



## LC5TDX

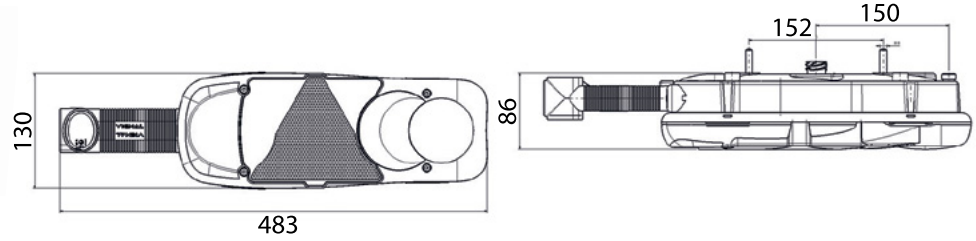

E2 06024 (sans DX)  
07092 (avec DX)

Affectations constructeurs  
Applicazione primo impianto  
Afectación primer equipo

ASCA p. 9



**153660**

gauche - sinistra - izquierda



AMP 1.5-7P-M  
arrière  
connettore posteriore  
conector trasero



**153670**

droit - destra - derecha



**153700**

gauche - sinistra - izquierda



**153710**

droit - destra - derecha



**D11868**

AMP 1.5-7P-F



**053700**

gauche - sinistra - izquierda

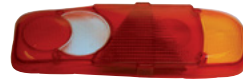

**053710**

droit - destra - derecha



**D12430**



**D12471**



**D12472**



**D12473**

Lampe non fournie - senza lam-  
padina - lampará no incluida

# Feux arriere - Fanali posteriori - Pilotos traseros

## LC7

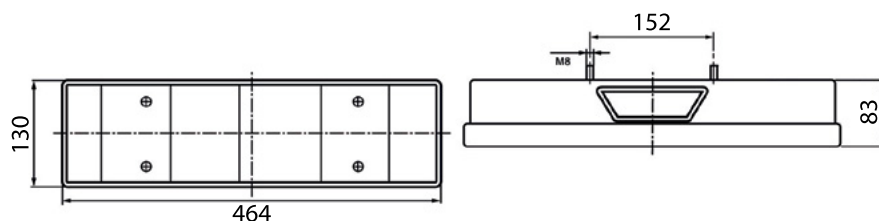

E<sub>2</sub> 88017 (LC7)  
88035 (LC7K)

Affectations constructeurs  
Applicazione primo impianto  
Afectación primer equipo

RENAULT TRUCKS p. 91



**167100**

EPP

**167600**

K EPP

gauche - sinistra - izquierda



PE  
arrière  
connettore posteriore  
conector trasero



**167000**

**167500**

K

droit - destra - derecha



**168270**

K FPL

gauche - sinistra - izquierda



**168270**

K FPL

droit - destra - derecha



**168340**

K FPL EPP

gauche - sinistra - izquierda

Affectations constructeurs  
Applicazione primo impianto  
Afectación primer equipo

MAN p. 71



**168090**

K FPL

gauche - sinistra - izquierda



DIN 72480-8P-M

arrière  
connettore posteriore  
conector trasero



**168090**

K FPL

droit - destra - derecha



**168100**

K FPL EPP

gauche - sinistra - izquierda



**067000**

**067500**

gauche - sinistra - izquierda



**067000**

**067500**

droit - destra - derecha

# Feux arriere - Fanali posteriori - Pilotos traseros

## LC7

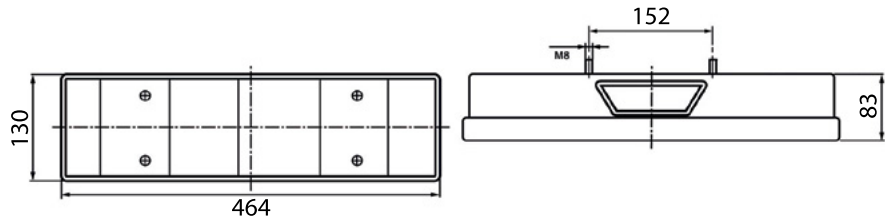

E<sub>2</sub> 88035 (LC7K)

Affectations constructeurs  
Applicazione primo impianto  
Afectación primer equipo

DAF p. 24  
MAN p. 72

Affectations constructeurs  
Applicazione primo impianto  
Afectación primer equipo

IVECO p. 48  
EURO 5



**169180** K FPL  
gauche - sinistra - izquierda



**AMP 1.5-7P-M**  
latéral  
connettore laterale  
conector lateral



**169170** K FPL  
**169190** K FPL Speaker  
droit - destra - derecha



**169160** K FPL EPP  
gauche - sinistra - izquierda



**168590** K FPL  
gauche - sinistra - izquierda



**IVECO**  
arrière  
connettore posteriore  
conector trasero



**168600** K FPL  
droit - destra - derecha



**168610** K FPL EPP  
gauche - sinistra - izquierda



**168480** K FPL Speaker  
droit - destra - derecha



**D11868** **AMP 1.5-7P-F**



**067500** K  
gauche - sinistra - izquierda



**067500** K  
droit - destra - derecha



# Feux arriere - Fanali posteriori - Pilotos traseros

## LC7

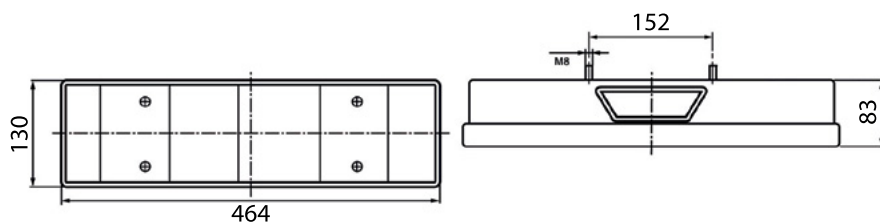

E<sub>2</sub> 88035 (LC7K)

Affectations constructeurs  
Applicazione primo impianto  
Afectación primer equipo

DAF p. 24

Affectations constructeurs  
Applicazione primo impianto  
Afectación primer equipo

IVECO p. 46

EURO 6



**168020**



gauche - sinistra - izquierda



DAF  
arrière  
connettore posteriore  
conector trasero



**168010**



droit - destra - derecha



**169390**



gauche - sinistra - izquierda



DIN 72480-8P-M  
arrière  
connettore posteriore  
conector trasero



**169410**

droit - destra - derecha



**169400**



gauche - sinistra - izquierda



**169420**



droit - destra - derecha



**D11868**

AMP 1.5-7P-F



**067500**



gauche - sinistra - izquierda



**067500**



droit - destra - derecha



**D12953**



# Feux arriere - Fanali posteriori - Pilotos traseros

## LC7T

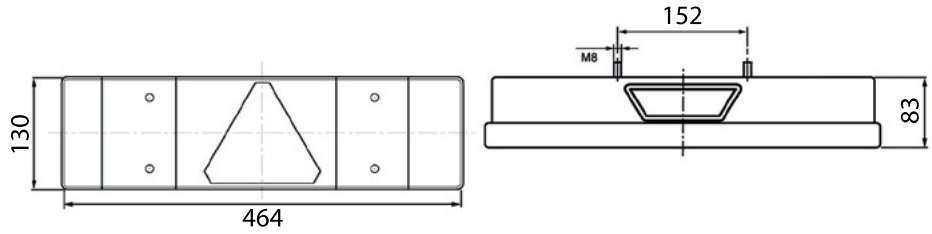

9056



**167530**



**168770**



gauche - sinistra - izquierda



PE  
arrière  
connettore posteriore  
conector trasero



**167550**



**168790**



droit - destra - derecha



**168780**



gauche - sinistra - izquierda



**168800**



droit - destra - derecha



**168830**



droit - destra - derecha



**067610**



gauche - sinistra - izquierda



**067600**



droit - destra - derecha

# Feux arriere - Fanali posteriori - Pilotos traseros

## LC6

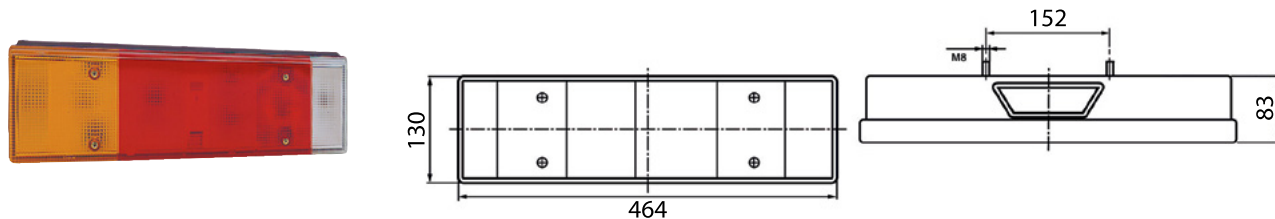

E2 88033 (LC6)  
88034 (LC6K)

Affectations constructeurs  
Applicazione primo impianto  
Afectación primer equipo

HEULIEZ p. 39  
IVECO BUS p. 55  
MAN p. 72  
RENAULT TRUCKS p. 91



**166000**

gauche - sinistra - izquierda



PE  
arrière  
connettore posteriore  
conector trasero



**166000**

droit - destra - derecha



**166100**

gauche - sinistra - izquierda



**166100**

droit - destra - derecha



**166600**

gauche - sinistra - izquierda



**166600**

droit - destra - derecha



**066000**

**066500**

gauche - sinistra - izquierda



**066000**

**066500**

droit - destra - derecha



**001706**

silent blocs

# Feux arriere - Fanali posteriori - Pilotos traseros

## LC4

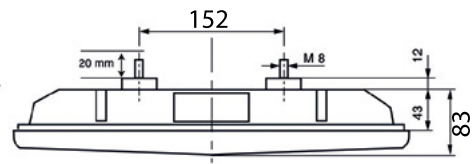
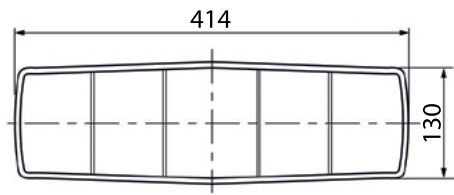
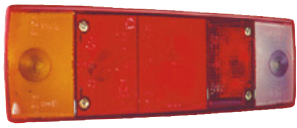

E2 91098 (LC4)  
91099 (LC4K)

Affectations constructeurs  
Applicazione primo impianto  
Afectación primer equipo

DAF p. 27  
RENAULT TRUCKSp. 108



**141000**

gauche - sinistra - izquierda



PE  
arrière  
connettore posteriore  
conector trasero



**141000**

droit - destra - derecha



**141500**

gauche - sinistra - izquierda



**141500**

droit - destra - derecha



**040000**

**040500**

gauche - sinistra - izquierda



**040000**

**040500**

droit - destra - derecha



**000046**

silent blocs

# Feux arriere - Fanali posteriori - Pilotos traseros

## 725



E13 8434

Affectations constructeurs  
Applicazione primo impianto  
Afectación primer equipo

IVECO p. 50

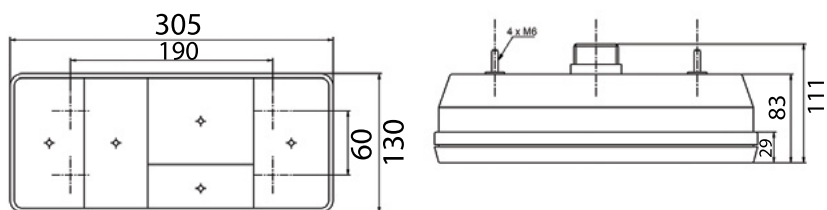

**D11482**

gauche - sinistra - izquierda



AMP 1.5-5P-M

arrière  
connettore posteriore  
conector trasero



**D11481**

droit - destra - derecha



**D11868**

AMP 1.5-7P-F



**D11480**

gauche - sinistra - izquierda



**D11479**

droit - destra - derecha



E13 2060

Affectations constructeurs  
Applicazione primo impianto  
Afectación primer equipo

IVECO p. 50



**D12334**

gauche - sinistra - izquierda



AMP 1.5-6P-M

arrière  
connettore posteriore  
conector trasero



**D12335**

droit - destra - derecha



**D11868**

AMP 1.5-7P-F



**D12336**

gauche - sinistra - izquierda



**D12337**

droit - destra - derecha



# Feux arriere - Fanali posteriori - Pilotos traseros

## 725



E<sub>3</sub> 51788

Affectations constructeurs  
Applicazione primo impianto  
Afectación primer equipo

IVECO p. 51

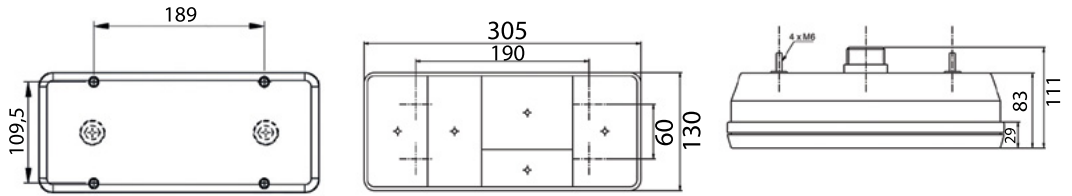

**725040**

gauche - sinistra - izquierda



IVECO  
arrière  
connettore posteriore  
conector trasero



**725020**

gauche - sinistra - izquierda



IVECO  
arrière  
connettore posteriore  
conector trasero



**725010**

droit - destra - derecha



**726310**

gauche - sinistra - izquierda

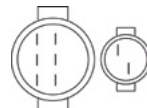

IVECO  
arrière  
connettore posteriore  
conector trasero



**726320**

droit - destra - derecha



**725002**

gauche - sinistra - izquierda



**725012**

droit - destra - derecha



**725022**

gauche - sinistra - izquierda



**725032**

droit - destra - derecha



# Feux arriere - Fanali posteriori - Pilotos traseros

## 725



E<sub>3</sub> 51788

Affectations constructeurs  
Applicazione primo impianto  
Afectación primer equipo

IVECO p. 51

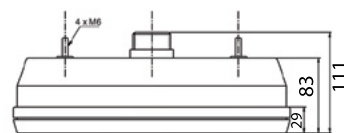
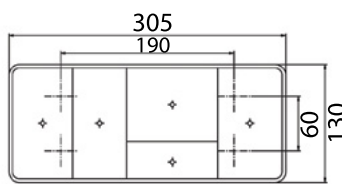
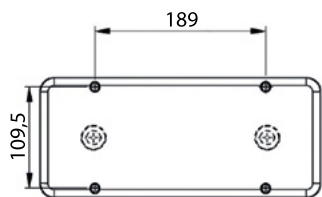

**726290**

gauche - sinistra - izquierda

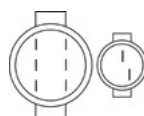

IVECO  
arrière  
connettore posteriore  
conector trasero

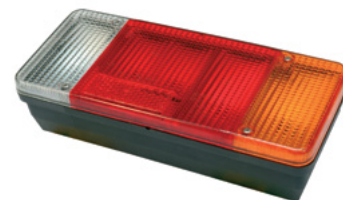

**726300**

droit - destra - derecha



**726350**

gauche - sinistra - izquierda

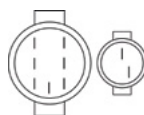

IVECO  
arrière  
connettore posteriore  
conector trasero



**726450**

gauche - sinistra - izquierda



IVECO  
arrière  
connettore posteriore  
conector trasero

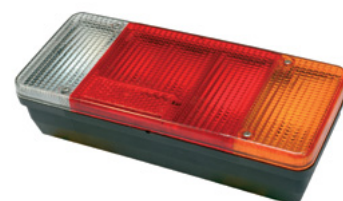

**726460**

droit - destra - derecha



**725002**

gauche - sinistra - izquierda



**725012**

droit - destra - derecha



**725022**

gauche - sinistra - izquierda



**725032**

droit - destra - derecha



# Feux arriere - Fanali posteriori - Pilotos traseros

## MILI



**E<sub>2</sub>** 88731 (5F)  
5108 (3F)  
253 (2F)

ROBUSTE ET ETANCHE  
ROBUSTO E IMPERMEABILE  
ROBUSTO E IMPERMEABILE

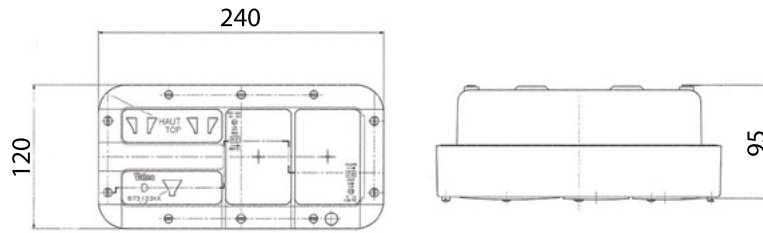

**67513371** gauche - sinistra - izquierda

**67513390**

cabochon - lente - tulipa



**67513361** droit - destra - derecha

**67513380**

cabochon - lente - tulipa



**60760541**

position - clignotant - black out position  
posizione - intermittente - black out  
posizione  
posición - intermitente - black out posición



**60760551**

brouillard - recul  
retronebbia - ritromarcia  
antiniebla - marcha atrás

## BBS 516



**E<sub>1</sub>** 1559  
53329

Affectations constructeurs  
Applicazione primo impianto  
Afectación primer equipo

MANITOU p. 73

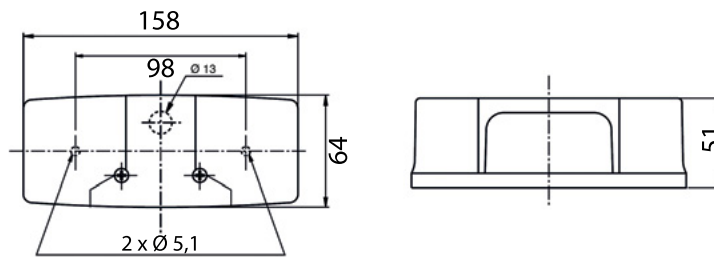

**500930**

gauche - sinistra - izquierda



PF  
arrière  
connettore posteriore  
conector trasero



**500940**

droit - destra - derecha





# Feux arriere - Fanali posteriori - Pilotos traseros

## FRR



Ø 140 mm x 80 mm

E13

9657 (3 fcts)  
697  
698



**D10841**

gauche/droit - sinistra/destra - izquierda/derecha



PF  
arrière  
connettore posteriore  
conector trasero



**D10840**

P21W

feu de recul  
luce di retromarcia  
piloto marcha atrás



**D10839**

P21W

feu de brouillard  
luce retronebbia  
piloto antiniebla

# Feux arriere - Fanali posteriori - Pilotos traseros

## 2711



E<sub>3</sub> 38553

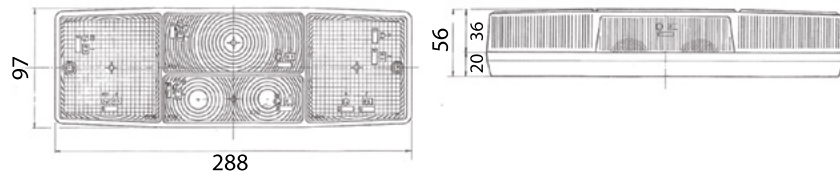

**D14523**  
(27.11.090.VLG)

**D14525**  
(27.11.991.VLG)

gauche - sinistra - izquierda



PE  
arrière  
connettore posteriore  
conector trasero



**D14524**  
(27.11.092.VLG)

**D14526**  
(27.11.992.VLG)

droit - destra - derecha



## 2704



E<sub>3</sub> 2887

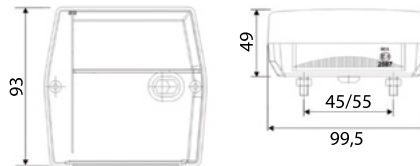

**D14518**  
(27.04.042.VLS)

gauche/droit - sinistra/destra - izquierda/derecha



PF  
arrière  
connettore posteriore  
conector trasero



**D14527**  
(27.04.V66.MV7) 7,5 m

valisette 2 feux câblés magnétiques  
valigetta kit 2 fanali magnetici cablati  
maleta 2 luces cableadas magnéticas

# Eclaireurs de plaque

Luci targa

Iluminación de placa

WWW.VIGNAL-GROUP.COM

## LED

p. 179-180

**NEW**



## Halogene

p. 181



SS-2P-F

Type connecteur - Nb pins - Mâle ou Femelle  
Tipo di connettore - Num pin - Maschio o Femmina  
Tipo de conector - Num pines - macho o hembra



Flashez le QR code pour plus d'infos  
Scansiona il codice QR per maggiori informazioni  
Escanee el código QR para obtener más info



Pièces détachées  
Ricambi  
Repuestos



Numéro d'homologation  
Numero di omologazione  
Número de aprobación



Sens de montage  
Direzione di montaggio  
Dirección de montaje



Faisceau p. 307  
Cablaggio p. 307  
Cableado p. 307

# Eclaireurs de plaque - Luci targa - Iluminación de placa

## LPL18

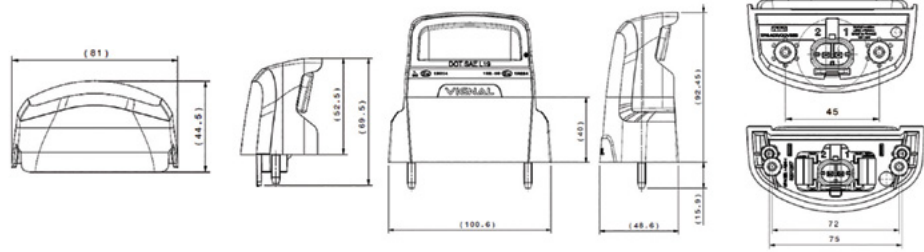

LED

12/24V

ADR



E<sub>2</sub> 19014  
10R-19224

SAE

IP6K9K

**NEW**



**199020**

SS-2P-M

Entraxe 72 mm  
Distanza del bullone di fissaggio 72 mm  
Distancia entre tornillos 72 mm



**199030**

SS-2P-M

Entraxe 75 mm  
Distanza del bullone di fissaggio 75 mm  
Distancia entre tornillos 75 mm

1 seul feu LED par plaque  
1 luce LED per piastra  
1 luz LED por placa



199020  
199030



**NEW**

Affectations constructeurs  
Applicazione primo impianto  
Afectación primer equipo

CASE p. 16  
IVECO p. 51  
LAMBERET p. 62  
NEW HOLLAND p. 80



**199000**

SS-2P-M

clippé - fissaggio con clip - fijación con clip



**199040**

SS-2P-M

Entraxe 45 mm  
Distanza del bullone di fissaggio 45 mm  
Distancia entre tornillos 45 mm

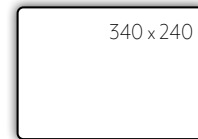
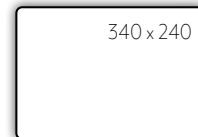

Plus d'implantations sur notre site web.  
Più posizionamento sul nostro sito web.  
Más posicionamiento en nuestra web



**D13880**

SS-2P-F

SS-2P-F

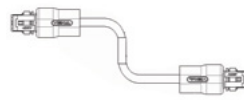

**D14985**

SS-2P-F



# Eclaireurs de plaque - Luci targa - Iluminación de placa

## EPP96 LED



LED

24V

ADR



E<sub>2</sub> 11017

Affectations constructeurs  
Applicazione primo impianto  
Afectación primer equipo

- ASCA p. 8
- BENALU p. 12
- DE BUF p. 28
- FRUEHAUF p. 35
- GUILLEN p. 37
- LAMBERET p. 61
- OMEPS p. 82
- SOR IBERICA p. 119

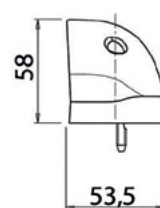
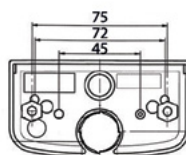
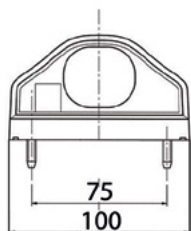

**D13609** 400 mm

**D13610** 1500 mm



**R14364** 2000 mm

2V Superseal  
Pour / Per / Para LC12T



**D13874** 2000 mm

2 voies - 2 vie - 2 vías  
Pour / Per / Para LC8

## BX868



LED

12/24V

E<sub>13</sub> 10989

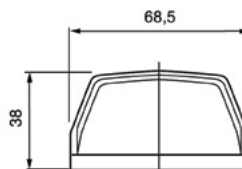
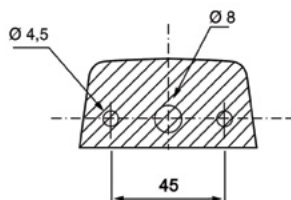

**D14116** 300 mm

# Eclaireurs de plaque - Luci targa - Iluminación de placa

## EPP96/98



R10W



12/24V

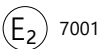

Affectations constructeurs  
Applicazione primo impianto  
Afectación primer equipo

- ASCA p. 8
- CHEREAU p. 21
- CLAAS p. 22
- FRUEHAUF p. 36
- GUILLEN p. 37
- LAMBERET p. 63
- MERCEDES p. 78
- RENAULT TRUCKS p. 101
- SOR IBERICA p. 120
- UD TRUCKS p. 124
- VOLVO TRUCKS p. 128

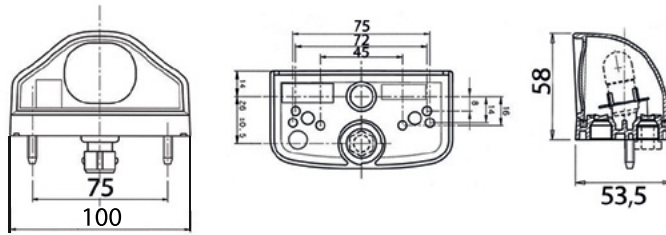

**196020**



**000176**

Affectations constructeurs  
Applicazione primo impianto  
Afectación primer equipo

- BOBCAT p. 15
- DAF p. 26
- OPEL p. 84
- RENAULT TRUCKS p. 101
- UD TRUCKS p. 124
- VOLVO TRUCKS p. 134



**CLICK-IN**

**D10502**

410 mm



**HDSCS-3P-M**

**196170**

500 mm



**POS-2P-F**

**D10227**

700 mm

2 voies - 2 vie - 2 vías  
Pour / Per / Para LC8



Affectations constructeurs  
Applicazione primo impianto  
Afectación primer equipo

- BOBCAT p. 15
- DAF p. 26
- OPEL p. 84
- RENAULT TRUCKS p. 101
- UD TRUCKS p. 124
- VOLVO TRUCKS p. 134



**196010**

**JPT-2P-M**



**D13876**

**JPT-2P-F**



**280009**

**JPT-2P-F**

2 m

## 2751



C5W



12/24V

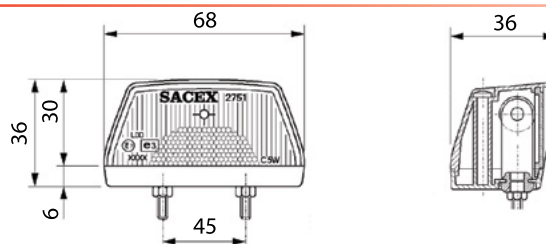
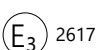

**D14517**

(27.51.090.VLG)

# Feux clignotants

Luci targa

Iluminación de placa



## Face avant - Parte anteriore - Parte delantera

p. 183-184

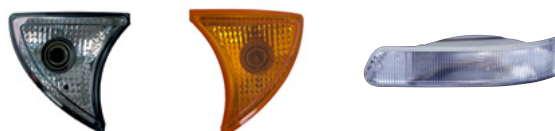

## Face avant - Parte laterale - Parte lateral

p. 185-188



JPT-2P-F

Type connecteur - Nb pins - Mâle ou Femelle  
Tipo di connettore - Num pin - Maschio o Femmina  
Tipo de conector - Num pines - macho o hembra



Flashez le QR code pour plus d'infos  
Scansiona il codice QR per maggiori informazioni  
Escanee el código QR para obtener más info



Pièces détachées  
Ricambi  
Repuestos



Numéro d'homologation  
Numero di omologazione  
Número de aprobación

# Feux clignotants - Luci intermittenti - Pilotos intermitentes

## C105

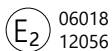

Affectations constructeurs  
Applicazione primo impianto  
Afectación primer equipo

IVECO p. 47



**110520**  
gauche - sinistra - izquierda

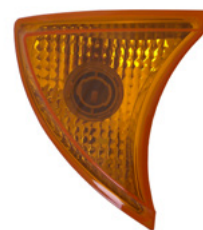

**110530**  
droit - destra - derecha



**110550**  
gauche - sinistra - izquierda



**110560**  
droit - destra - derecha



**001619**

## C199

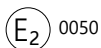

Affectations constructeurs  
Applicazione primo impianto  
Afectación primer equipo

IVECO p. 47



**119920**  
gauche - sinistra - izquierda



**119930**  
droit - destra - derecha



## FLASHER UNIT



### 014580

Renault 5010149149  
5 lampes, centrale clignotante  
5 luci, lampeggiatore  
5 lamparas, unidad intermitente

## SRD08



LED

24V

E<sub>2</sub> 10073

Affectations constructeurs  
Applicazione primo impianto  
Afectación primer equipo

[VOLVO TRUCKS p. 127](#)



**111000**

gauche - sinistra - izquierda



**111010**

droit - destra - derecha



**111020**

gauche - sinistra - izquierda



**111030**

droit - destra - derecha

## SRD07



LED

24V

E<sub>2</sub> 08028

Affectations constructeurs  
Applicazione primo impianto  
Afectación primer equipo

[VOLVO TRUCKS p. 128](#)



**107000**

gauche - sinistra - izquierda



**107010**

droit - destra - derecha



**107040**

gauche - sinistra - izquierda



**107050**

droit - destra - derecha



**107500**

gauche - sinistra - izquierda



**107510**

droit - destra - derecha

## ICDL15



P21W



16059



**120000**

Affectations constructeurs  
Applicazione primo impianto  
Afectación primer equipo

[UD TRUCKS p. 124](#)

## ICDL10



PY21W



11128



**117000**

gauche - sinistra - izquierda



**117010**

droit - destra - derecha

Affectations constructeurs  
Applicazione primo impianto  
Afectación primer equipo

[DAF p. 25](#)



**001619**

## ICDL07



PY21W



09025



**109010**

Affectations constructeurs  
Applicazione primo impianto  
Afectación primer equipo

[DAF p. 24](#)



# Feux clignotants - Luci intermittenti - Pilotos intermitentes

## ICDL94



E2 5047 (R5W)  
7139 (P21W)

Affectations constructeurs  
Applicazione primo impianto  
Afectación primer equipo

DAF p. 26  
IVECO p. 52  
IVECO BUS p. 55  
NISSAN p. 81  
RENAULT TRUCKS p. 97  
VOLVO TRUCKS p. 133

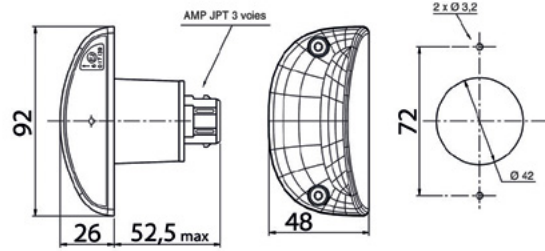

R5W

**119450**



**119550**



P21W

**119470**



**D13877**

JPT-2P-F



**001616**

JPT-2P-M

## FE85



E2 86708  
9033

Affectations constructeurs  
Applicazione primo impianto  
Afectación primer equipo

RENAULT TRUCKS p. 92



R5W



**185040**



P21W



**185160**

# Feux clignotants - Luci intermittenti - Pilotos intermitentes

## FE87



C5W



4703

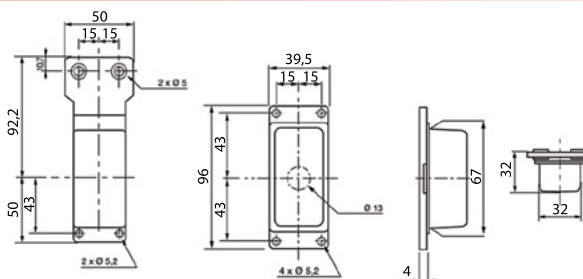

**187140**



**187760**



**087040**

cabochon - lente - tulipa

## FE81



T4W



90711

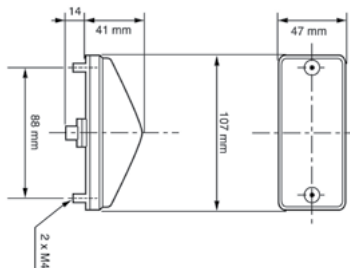

**181050**

**181070**

version pétrolière  
versione petroliere  
versión petroleros



**000086**

# Feux de position

## Luci di posizione

### Pilotos de posición



**Face avant - Parte anteriore - Parte delantera**  
p. 190-195



**Face latérale - Parte laterale - Parte lateral**  
p. 196-201



**Face arrière - Parte posteriore - Parte trasera**  
p. 202-205



K

Catadioptré  
Catarifrangente  
Catadióptico



Flashez le QR code pour plus d'infos  
Scansiona il codice QR per maggiori informazioni  
Escanee el código QR para obtener más info



Pièces détachées  
Ricambi  
Repuestos



Numéro d'homologation  
Numero di omologazione  
Número de aprobación



Sens de montage  
Direzione di montaggio  
Dirección de montaje

DT-2P-M

Type connecteur - Nb pins - Mâle ou Femelle  
Tipo di connettore - Num pin - Maschio o Femmina  
Tipo de conector - Num pines - macho o hembra



Faisceau p. 307  
Cablaggio p. 307  
Cableado p. 307

# Feux de position - Luci di posizione - Pilotos de posición

## FE04



LED

24V

ADR



E2 05010  
SAE P2

Affectations constructeurs  
Applicazione primo impianto  
Afectación primer equipo

ASCA p. 10  
LAMBERET p. 63  
RENAULT TRUCKS p. 92

p. 202

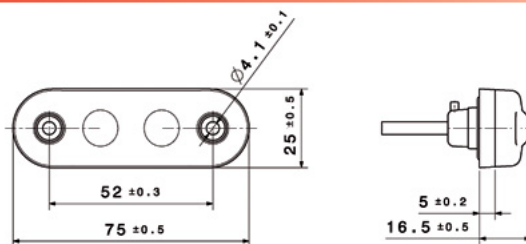

<b>104290</b>	500 mm
<b>104300</b>	1500 mm
<b>104310</b>	5000 mm

<b>D10132</b>	200 mm
---------------	--------

CLICK-IN



<b>104570</b>	300 mm
---------------	--------

DT-2P-M



<b>104450</b>	300 mm
---------------	--------

DT-2P-M



<b>D14170</b>
---------------

DT-2P-F



<b>104510</b>	300 mm
---------------	--------

CLICK-IN

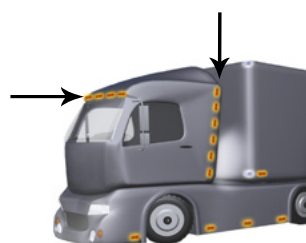

<b>D11268</b>	16 m
---------------	------

câble plat - cavo piatto - manguera plana

# Feux de position - Luci di posizione - Pilotos de posición

## SMD04



LED

24V

ADR



E<sub>2</sub> 05022

p. 196

p. 202

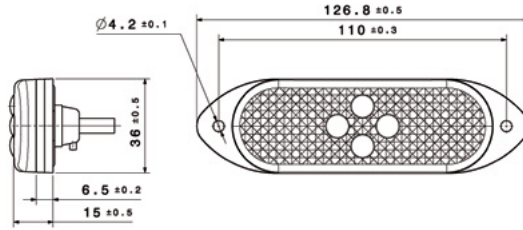

**104130** 500 mm **K**

**104140** 1500 mm **K**

**104520** 1000 mm **K**

**104690** 1000 mm **K**

CLICK-IN

adhésif - adesivo - adhesivo

CLICK-IN

SS-2P-M

**NEW**

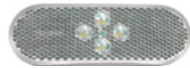

**104720** **K**

SS-2P-M

## SMD98



LED

12V  
ou-o  
24V

ADR



E<sub>2</sub> 04010

p. 197

p. 203

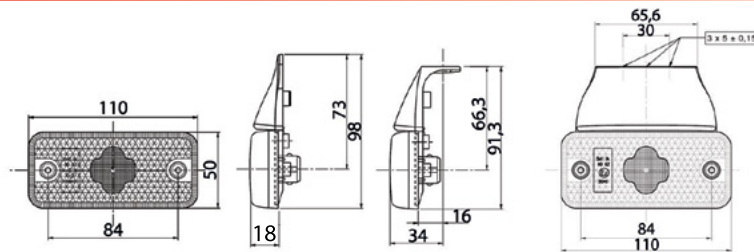

**198690** 12V **K**

**D10500** 500 mm **K**

**D13710** 1000 mm **K**

**198660** 24V **K**

**D11399** 1500 mm **K**

JPT-2P-M

CLICK-IN

POS-2P-F

2 voies - 2 vie - 2 vías  
Pour / Per / Para LC8



**D13876** JPT-2P-F



**001696**



**001716**



# Feux de position - Luci di posizione - Pilotos de posición

## FE94/98



T4W



12/24V

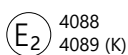

4088  
4089 (K)



p. 198



p. 203

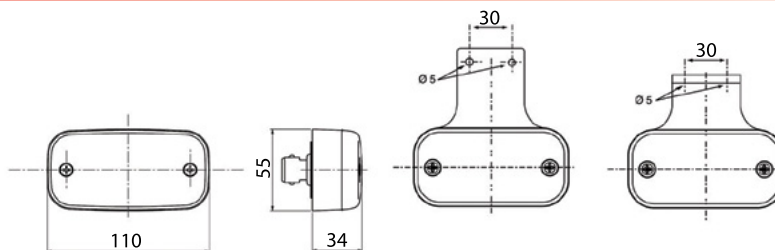

**198040**



JPT-2P-M



**198050**



**194190**



PE



**194130**



**194140**



**194150**



**D13876**

JPT-2P-F



**000176**



**094046**



**094036**



**001596**



**001586**

## FE02

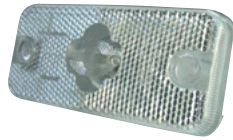
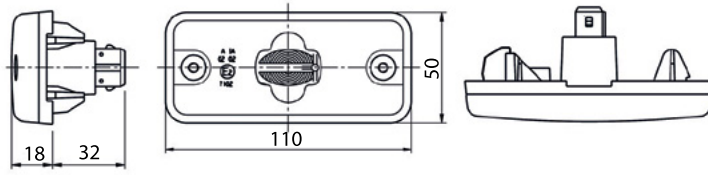

**102200** K  
clippé - fissaggio con clip - fijación con clip

**D13876** **JPT-2P-F** **001726**

## FPL93

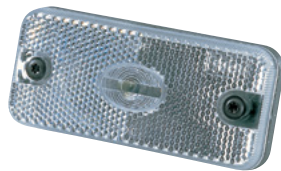
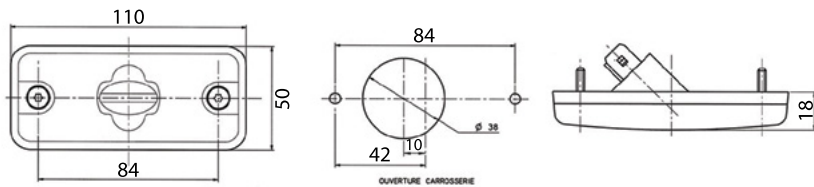

**193200** K  
vissé - avvitato - atornillado

**D13876** **JPT-2P-F** **001726**



## FE95



140 mm x 65 mm x 30,5 mm



**195010**  
semelle plate - base piatta - base plana

**195030**  
semelle galbée - base sagomata - base curvada

Affectations constructeurs  
Applicazione primo impianto  
Afectación primer equipo

DAF p. 26  
HEULIEZ p. 39  
IVECO BUS p. 54  
RENAULT TRUCKS p. 96  
VOLVO TRUCKS p. 133

# Feux de position - Luci di posizione - Pilotos de posición

## FE85



175 mm x 68 mm x 52 mm



R5W



24V



9037

Affectations constructeurs  
Applicazione primo impianto  
Afectación primer equipo

HEULIEZ p. 39

IVECO BUS p. 57

RENAULT TRUCKS p. 92



**185010**

semelle galbée - base sagomata - base curvada



**185020**

semelle plate - base piatta - base plana

## FE87

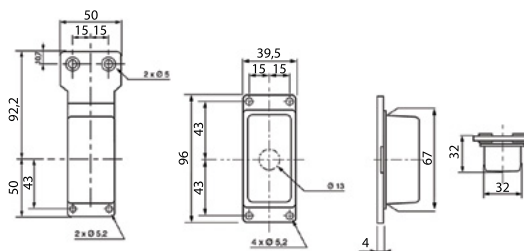

C5W



12/24V



86710



**187120**



**187720**



**087020**

cabochon - lente - tulipa

## PLR272



C5W



12/24V

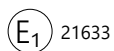

21633

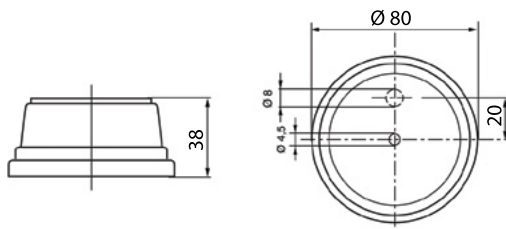

**521010**



**521050**



cabochon - lente - tulipa

## FG80



R5W



12/24V

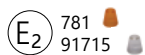

781

91715

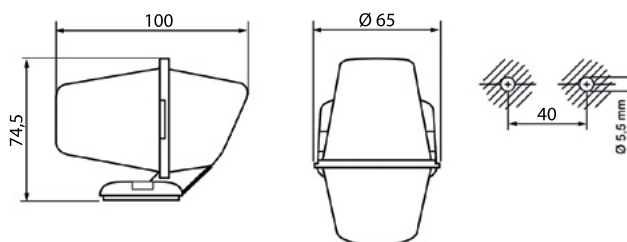

**180010**



**080026**



**180040**

R5W



**080046**

# Feux de position - Luci di posizione - Pilotos de posición

## SMD04

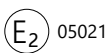
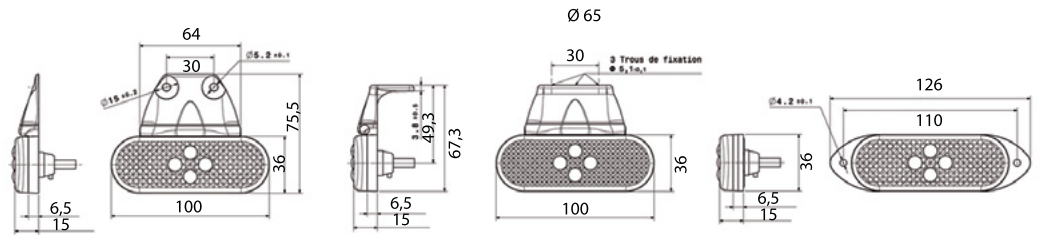

<b>104090</b>	500 mm	K	<b>104210</b>	500 mm	K	<b>104250</b>	500 mm	K
<b>104100</b>	1500 mm	K	<b>104220</b>	1500 mm	K	<b>104260</b>	1500 mm	K
CLICK-IN			CLICK-IN			CLICK-IN		



<b>104640</b>	300 mm	K	<b>D12699</b>	1000 mm	K
<b>104650</b>	1000 mm	K	CLICK-IN		
bride rallongée - supporto esteso - soporte extendido					



<b>104670</b>		K	<b>104700</b>	LED-24V	K
SS-2P-M			SS-2P-M		



<b>D13880</b>	SS-2P-F
---------------	---------

## SMCU



FEUX DE POSITION LATÉRAUX LED CLIGNOTANTS gestion selon supplément 6 - R48  
 LUCI LATERALI LED LAMPEGGIANTI gestione secondo supplemento 6 - R48  
 PILOTOS DE POSICION LED INTERMITENTES según suplemento 6 - R48

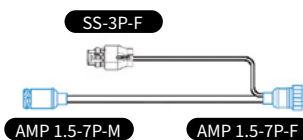

**D14722**

LED Side marker control unit

**D14879**



**D14362**

SS-3P-F



**D13880**

SS-2P-F



# Feux de position - Luci di posizione - Pilotos de posición

## SMD98



LED

12V  
ou-o  
24V

ADR

4xLED

2xLED

E<sub>2</sub> 8040

p. 191

p. 203

Affectations constructeurs  
Applicazione primo impianto  
Afectación primer equipo

- CASE p. 16
- FELDBINDER p. 33
- IVECO p. 45
- IVECO BUS p. 54
- LAMBERET p. 64
- LECINENA p. 67
- MERCEDES p. 78
- MANITOWOC p. 75
- NEW HOLLAND p. 80
- RENAULT TRUCKS p. 97
- VOLVO BUS p. 135
- VOLVO CONSTRUCTION p. 136

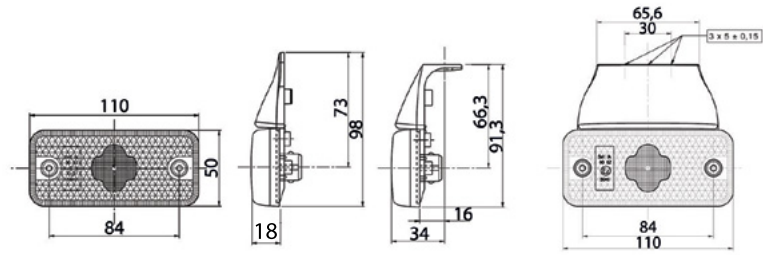

<b>198510</b> 4 x LED-12V <span style="float: right;">K</span>	<b>198520</b> 4 x LED-24V <span style="float: right;">K</span>	<b>198650</b> 2 x LED-24V <span style="float: right;">K</span>	<b>198810</b> 4 x LED-12V <span style="float: right;">K</span>
JPT-2P-M	JPT-2P-M	JPT-2P-M	SS-2P-M
<b>198580</b> 4 x LED-12V <span style="float: right;">K</span>	<b>198530</b> 2 x LED-24V <span style="float: right;">K</span>	<b>198540</b> 2 x LED-24V <span style="float: right;">K</span>	<b>D13713</b> 1000 mm <span style="float: right;">K</span>
JPT-2P-M	JPT-2P-M	JPT-2P-M	POS-2P-F 2 x LED-24V 2 voies - 2 vie - 2 vías Pour / Per / Para LC8
<b>D10493</b> 500 mm <span style="float: right;">K</span>	<b>D10494</b> 500 mm <span style="float: right;">K</span>	<b>D10495</b> 500 mm <span style="float: right;">K</span>	<b>D10496</b> 1500 mm <span style="float: right;">K</span>
<b>D10496</b> 1500 mm <span style="float: right;">K</span>	<b>D10497</b> 1500 mm <span style="float: right;">K</span>	<b>D10497</b> 1500 mm <span style="float: right;">K</span>	<b>D10498</b> 1500 mm <span style="float: right;">K</span>
CLICK-IN	CLICK-IN	CLICK-IN	CLICK-IN
<b>D12867</b> 2 x LED-24V <span style="float: right;">K</span>			
CLICK-IN			
<b>D13876</b> <span style="float: right;">JPT-2P-F</span>	<b>D13880</b> <span style="float: right;">SS-2P-F</span>	<b>001696</b>	<b>001716</b>



# Feux de position - Luci di posizione - Pilotos de posición

## SMD00

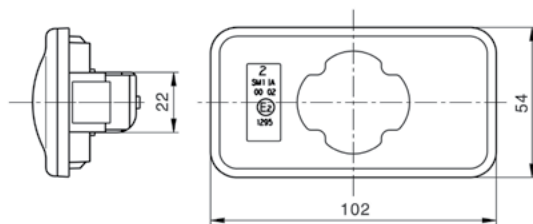

LED

24V

ADR



E<sub>2</sub> 1295

Affectations constructeurs  
Applicazione primo impianto  
Afectación primer equipo

RENAULT TRUCKSp. 88  
VOLVO TRUCKS p. 130



**198620**



Cuve blanche - cabochon PMMA  
Scatola bianca - lente PMMA  
Caja blanca - tulipa PMMA

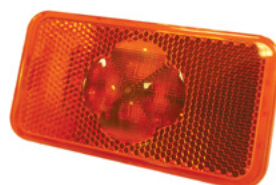

**198740**



Cuve ambre - cabochon PC résistant haute température et chocs  
Scatola arancione - lente PC resistenti alle alte temperature e agli urti  
Caja naranja - tulipa de PC resistente a altas temperaturas y golpes



**001766** 600 mm

adaptateur - adattatore - adaptador

## FE94/98

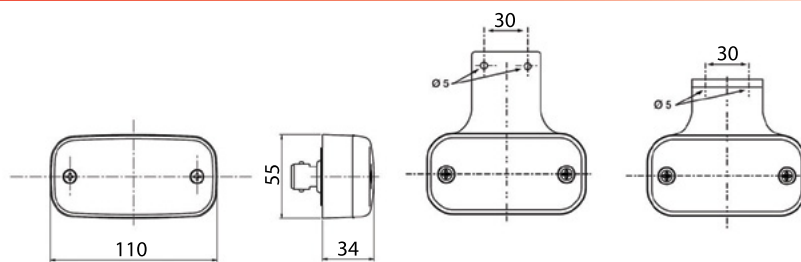

T4W

12/24V

ADR



E<sub>2</sub> 4092  
4093 (K)

 p. 192

 p. 204



**198010**



**198020**



**198030**



**D13876**

JPT-2P-F

## FE94/98

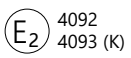

194070



PE



194010



194080



194020



194090



194030



D13876

JPT-2P-F



000176



094026



094016



001596



001586



001696



001716



# Feux de position - Luci di posizione - Pilotos de posición

## FPL93

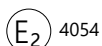
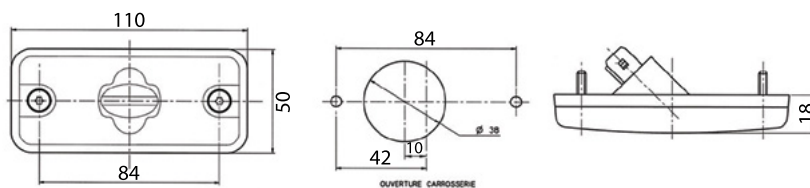

Affectations constructeurs  
Applicazione primo impianto  
Afectación primer equipo

- DAF p. 25
- FIAT p. 34
- HEULIEZ p. 40
- IVECO p. 45
- IVECO BUS p. 57
- RENAULT TRUCKSp. 92
- VOLVO TRUCKS p. 134



**193020**



JPT-2P-M



**193280**



JPT-2P-M



**193170**



SS-2P-M



**193360**



SS-2P-M



**193290**

380 mm



SS-2P-M



**D13876**

JPT-2P-F



**D13880**

SS-2P-F



**001726**

JPT-2P-M



**001916**

SS-2P-M



**001696**



**001716**

## 672



W3W

12/24V

E<sub>9</sub> 1084

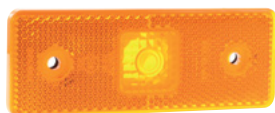
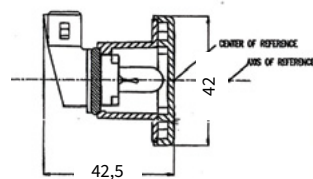
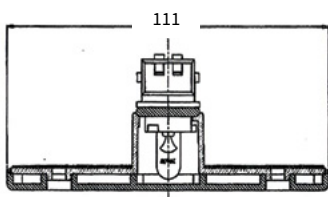

**672410** 200 mm K

## FE87



C5W

12/24V

E<sub>2</sub> 4701

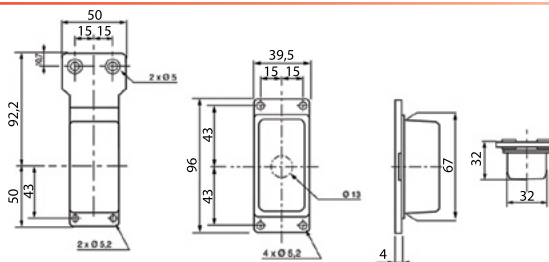

**187140**



**187760**



**087040**

cabochon - lente - tulipa

# Feux de position - Luci di posizione - Pilotos de posición

## FE04



LED

24V

ADR



E<sub>2</sub> 05011

p. 190

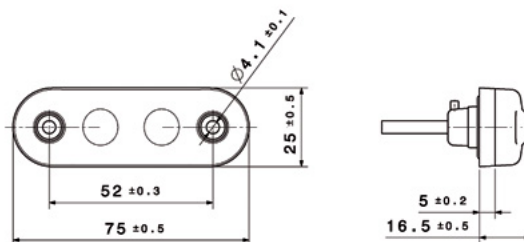

<b>104330</b>	500 mm
<b>104340</b>	1500 mm
<b>104360</b>	5000 mm



**D10132** 200 mm  
**CLICK-IN**

## SMD04



LED

24V

ADR



E<sub>2</sub> 05023

p. 191

p. 196

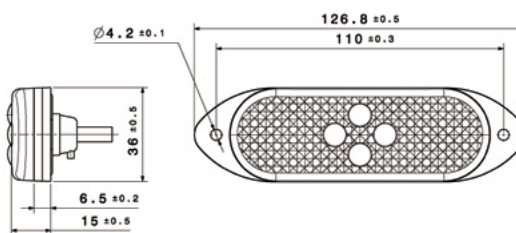

**NEW**

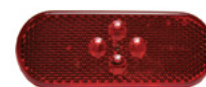

<b>104170</b>	500 mm	<b>K</b>
<b>104180</b>	1500 mm	<b>K</b>

**CLICK-IN**

<b>104680</b>	<b>K</b>	<b>104710</b>	<b>K</b>
---------------	----------	---------------	----------

**SS-2P-M**

**SS-2P-M**



**D13880** **SS-2P-F**

# Feux de position - Luci di posizione - Pilotos de posición

## SMD98



LED

24V

ADR

H

E<sub>2</sub> 2065

p. 191

p. 197

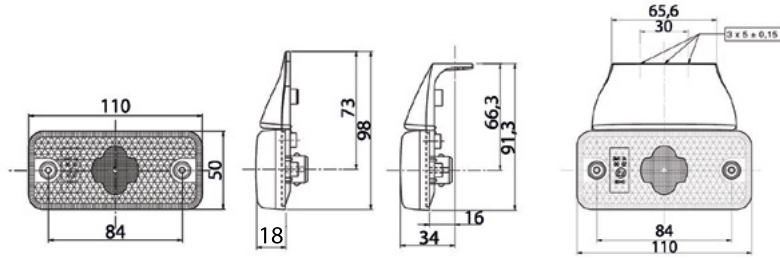

198640

D11400 1500 mm

D10499 3500 mm

K

K

K

JPT-2P-M

CLICK-IN



D13876

JPT-2P-F



001696



001716

## FE94/98



T4W

12/24V

ADR

H V

E<sub>2</sub> 4090  
4091 (K)

p. 192

p. 199

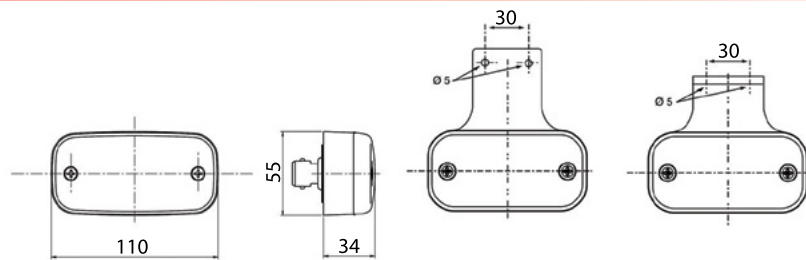

198060



JPT-2P-M

# Feux de position - Luci di posizione - Pilotos de posición

## FE94/98



T4W



12/24V



E<sub>2</sub> 4090  
4091 (K)

p. 192

p. 199

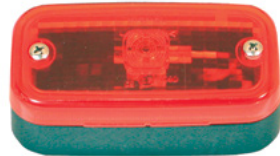
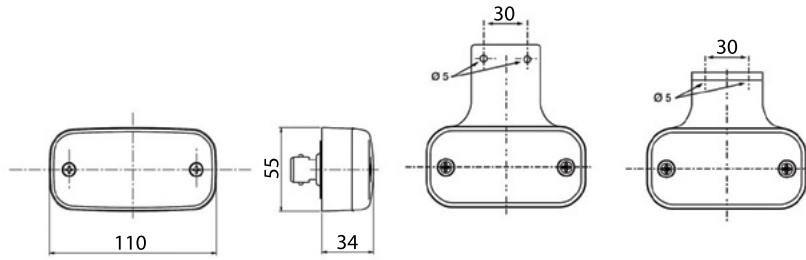

**194310**



PE



**194250**

**K**



**194260**

**K**



**194270**

**K**



**D13876**

**JPT-2P-F**



**000176**



**094066**



**094056**

**K**



**001596**



**001586**

## FE87



C5W



12/24V



86711

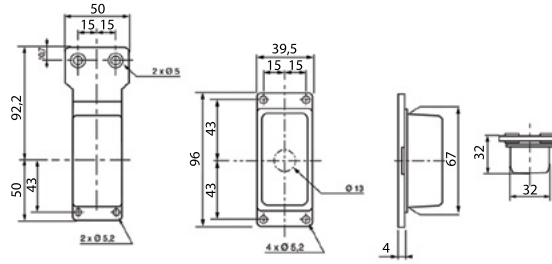

**187130**



**187730**



**087030**

cabochon - lente - tulipa

## FE95



R5W



12/24V

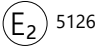

5126

Affectations constructeurs  
Applicazione primo impianto  
Afectación primer equipo

HEULIEZ p. 39  
IVECO BUS p. 54

140 mm x 65 mm x 30,5 mm



**195060**

## FE85



R5W



24V

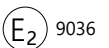

9036

175 mm x 68 mm x 52 mm



**185030**

semelle galbée - base sagomata - base curvada



**185050**

semelle plate - base piatta - base plana

# Feux de gabarits Luci d'ingombro Luces de anchura



## Tricolore - Tricolore - Tricolor p. 207-209



## Bicolore - Bicolore - Bicolor p. 210-212



SS-2P-F

Type connecteur - Nb pins - Mâle ou Femelle  
Tipo di connettore - Num pin - Maschio o Femmina  
Tipo de conector - Num pines - macho o hembra



Flashez le QR code pour plus d'infos  
Scansiona il codice QR per maggiori informazioni  
Escanee el código QR para obtener más info



Pièces détachées  
Ricambi  
Repuestos



Numéro d'homologation  
Numero di omologazione  
Número de aprobación

# Feux de gabarits - Luci d'ingombro - Luces de anchura

## FA3 LED



LED

12/24V

ADR

E<sub>2</sub> 14010

\* fils nus - estremità cavo nuda - cable pelado

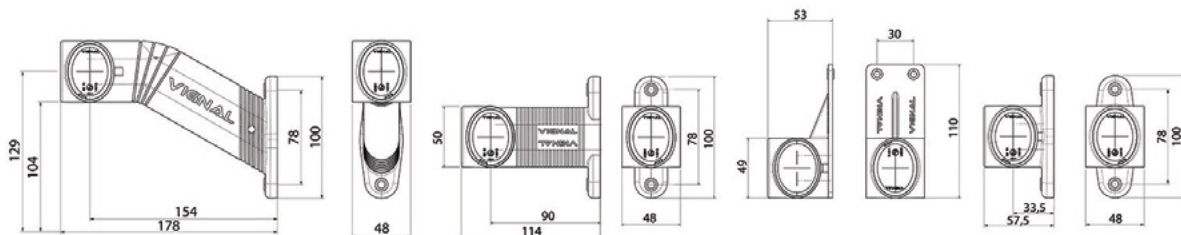

**D14421\*** 1700 mm

**D14427** 1500 mm

gauche - sinistra - izquierda

CLICK-IN



**D14422\*** 1700 mm

**D14428** 1500 mm

droit - destra - derecha

CLICK-IN



**D14423** 1500 mm

gauche - sinistra - izquierda

POS-2P-F



Pour / Per / Para LC8  
D14423 - D14424 - D13875



**D14424** 1500 mm

droit - destra - derecha

POS-2P-F



**D14425** 1500 mm

gauche - sinistra - izquierda

SS-2P-F



Pour / Per / Para LC12T  
D14425 - D14426 - D14655



**D14426** 1500 mm

droit - destra - derecha

SS-2P-F



**D14431\*** 1700 mm

**D14429** 1500 mm

CLICK-IN



**D14432\*** 1700 mm

**D14430** 1500 mm

droit - destra - derecha

CLICK-IN



**D14031\*** 1700 mm

**D14035** 1500 mm

**D14655** 1500 mm

symétrique - simmetrico - simétrico

CLICK-IN

SS-2P-F



**D14030\*** 1700 mm

**D14034** 1500 mm

**D13875** 1500 mm

symétrique - simmetrico - simétrico

CLICK-IN

POS-2P-F



# Feux de gabarits - Luci d'ingombro - Luces de anchura

## FA3 LC12 LED



LED

12/24V

ADR

E<sub>2</sub> 14010



**NEW**



**D14781** 350 mm  
gauche - sinistra - izquierda **SS-2P-F**



**D14782** 350 mm  
droit - destra - derecha **SS-2P-F**

## FA3 LED LC8



LED

12/24V

ADR

E<sub>2</sub> 14010



**D14038** 500 mm  
gauche - sinistra - izquierda **CLICK-IN**



**D14037** 500 mm  
droit - destra - derecha **CLICK-IN**



**D14039** 350 mm  
gauche - sinistra - izquierda **POS-2P-F**



**D14040** 350 mm  
droit - destra - derecha **POS-2P-F**

# Feux de gabarits - Luci d'ingombro - Luces de anchura

## DX LC8



W5W



24V

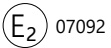

**D13034** 500 mm  
gauche - sinistra - izquierda **CLICK-IN**



**D13035** 500 mm  
droit - destra - derecha **CLICK-IN**



**D12712** 350 mm  
gauche - sinistra - izquierda **POS-2P-F**



**D12711** 350 mm  
droit - destra - derecha **POS-2P-F**

## DX



W5W



24V

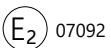

**D12430**



**D12429**

1500 mm

**CLICK-IN**



**D12428**

1400 mm

**CLICK-IN**



**D12471**



**D12473**

**K**



**D12472** 1500 mm

Lampe non fournie - senza lampadina - lampará no incluida

# Feux de gabarits - Luci d'ingombro - Luces de anchura

## DX LED



90 mm x 50 mm x 180 mm



**D13624**

fils nus - estremità cavo nuda - cable pelado

LED

12/24V

E<sub>20</sub> 020889  
020890



## DX

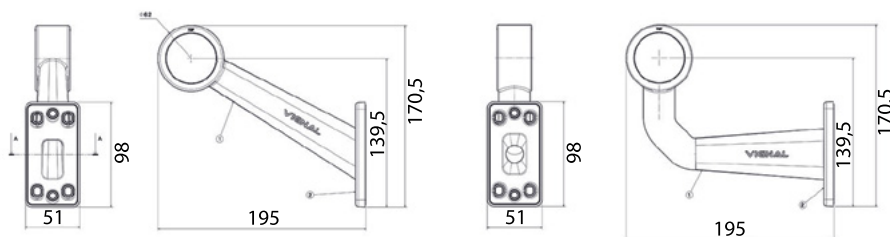

W5W

12/24V

ADR

E<sub>2</sub> 10035



\* fils nus - estremità cavo nuda - cable pelado



**D10642 \***



**D10643 \***



**D10503**

600 mm

CLICK-IN



**D10800**

R5W - 12/24V



**D11899**

500 mm

2 voies - 2 vie - 2 vías  
Pour / Per / Para LC8



POS-2P-F



**611010**



**D13277** 350 mm



**D11147** 500 mm



**610080** R5W

**611020**



Lampe non fournie - senza lam-  
padina - lampará no incluida

# Feux de gabarits - Luci d'ingombro - Luces de anchura

## FE12



LED

12/24V

E<sub>24</sub> 020078



\* fils nus - estremità cavo  
nuda - cable pelado

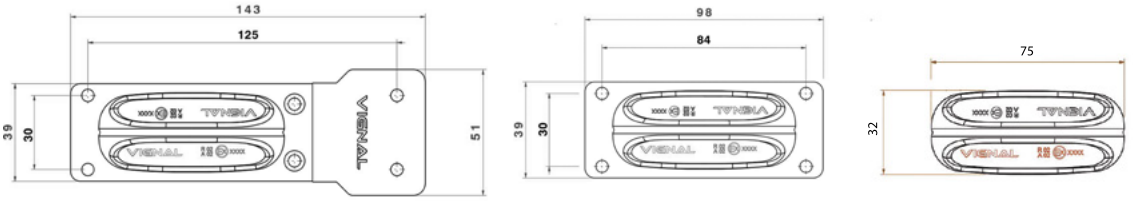

**112110** \* 1000 mm

**112130** 1500 mm **CLICK-IN**



**112710** \* 1000 mm

**112720** 1500 mm **CLICK-IN**



**112120** \* 1000 mm

**112140** 1500 mm **CLICK-IN**

## FE88



C5W

12/24V

E<sub>2</sub> 88714

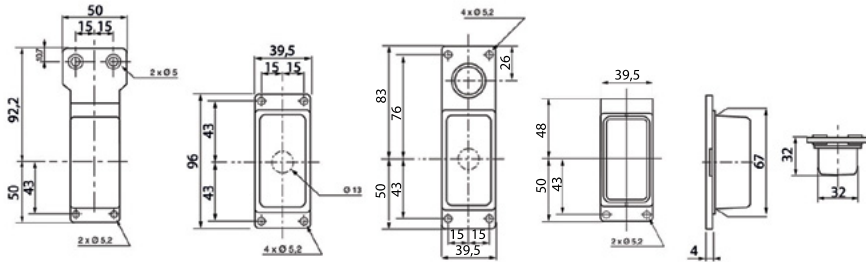

**188110**



**188210**



**188010**

pour presse-étoupe 000176  
per guarnizione pressacavo 000176  
para prensa estopa 000176



**188710**



**188610**



**188310**



**088010**

cabochon - lente - tulipa



**000176**

## FE81



107 mm x 47 mm x 41 mm



T4W



12/24V



**181000**



**000086**

# Signalisation passive

## Segnaletica passiva

## Señalización



**Plaques réfléchissantes - Targhe riflettenti - Placas reflectantes**  
p. 214



**Bandes réfléchissantes - Nastri riflettenti - Cintas reflectantes**  
p. 215



**Catadioptres - Catadiottri - Catadióptricos**  
p. 216



**Triangle de présignalisation - Triangolo di segnalazione - Triángulo de emergencia**  
p. 217



Flashez le QR code pour plus d'infos  
Scansiona il codice QR per maggiori informazioni  
Escanee el código QR para obtener más info



Pièces détachées  
Ricambi  
Repuestos



Numéro d'homologation  
Numero di omologazione  
Número de aprobación

# Plaques réfléchissantes - Targhe riflettenti - Placas reflectantes

## R70



### Camions / Cars et bus - Camion / Autobus - Camiones / Autobuses

1 x (130 x 1130)

2 x (130 x 565)

4 x (130 x 282)

E<sub>11</sub> 010002



\* adhésif - autoadesivo - adhesivo



**D14710** Alu 1 mm

**D14706** Adhésif \*

**D14711** Alu 1 mm

**D14707** Alu 1 mm

**D14535** Plastique

### Remorques - Rimorchio - Remolques

1 x (195 x 1130)

2 x (195 x 565)

4 x (195 x 283)



**D14712** Alu 1 mm

**D14708** Adhésif \*

**D14713** Alu 1 mm

**D14709** Alu 1 mm

**D14536** Plastique

## VC69



E R69

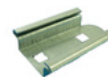
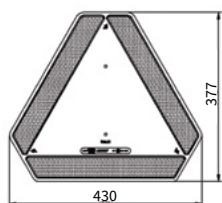

**D14532**

Véhicules lents - Veicoli lenti - Vehículos lentos

**D14533**

**D14534**

# Bandes réfléchissantes - Nastri riflettenti - Cintas reflectantes

## R104



50 m x 50,8 mm

Surface rigide - Struttura rigida - Estructura rígida

E13 0001



**D12713**



**D12715**



**D12714**

E13 0002

Surface souple - Superfici telonate - Estructura flexible



**D13206**



**D13205**



**D13207**

Carrés pré-espacés - pezzi pre-tagliati - cuadrados espaciados

## BA



2 x 9 m x 141 mm



**D14714** Cl. A: >80m

**D14716** Cl. B: >500m

Classe 1 : ville et route nationale - Strade urbane - Ciudad y carreteras nacionales  
Classe 2 : autoroutes et voies rapides - Strade extraurbane - autovías

2 x 45 m x 141 mm



**D14715** Cl. A: >80m



# Catadioptrés - Catadiottri - Catadióptricos

## CA



Plastique - Struttura in plastica - Estructura en plástica

Ø 61 mm	Ø 85 mm	57 mm x 39 mm
<b>D14592</b>	<b>D14589</b>	<b>D14595</b>
<b>D14591</b>	<b>D14588</b>	<b>D14594</b>
<b>D14593</b>	<b>D14590</b>	<b>D14596</b>
105 mm x 45 mm	105 mm x 45 mm - M4	90 mm x 39 mm
<b>240366</b>	<b>241366</b>	<b>624036</b>
<b>240346</b>	<b>241346</b>	<b>624016</b>
<b>240356</b>	<b>241356</b>	<b>624026</b>
adhésif - autoadesivo - adhesivo		adhésif - autoadesivo - adhesivo
159 mm x 159 mm x 159 mm		
<b>D14587</b>		

## DSR



250 mm x 170 mm	250 mm x 170 mm
<b>NEW</b>	
<b>D14990</b>	<b>D14991</b>
Camions et poids lourds	Cars et bus

# TRI



Affectations constructeurs  
Applicazione primo impianto  
Afectación primer equipo

RENAULT TRUCKS p. 86

SCANIA p. 116

VOLVO CONSTRUCTION p. 136

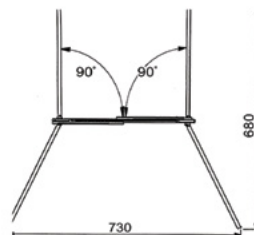
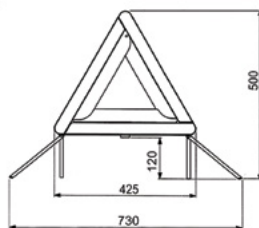

**D10596**  
(564.VTO.VLG)

# Phares homologués recul

## Fari omologati retromarcia

### Faros homologados marcha atrás

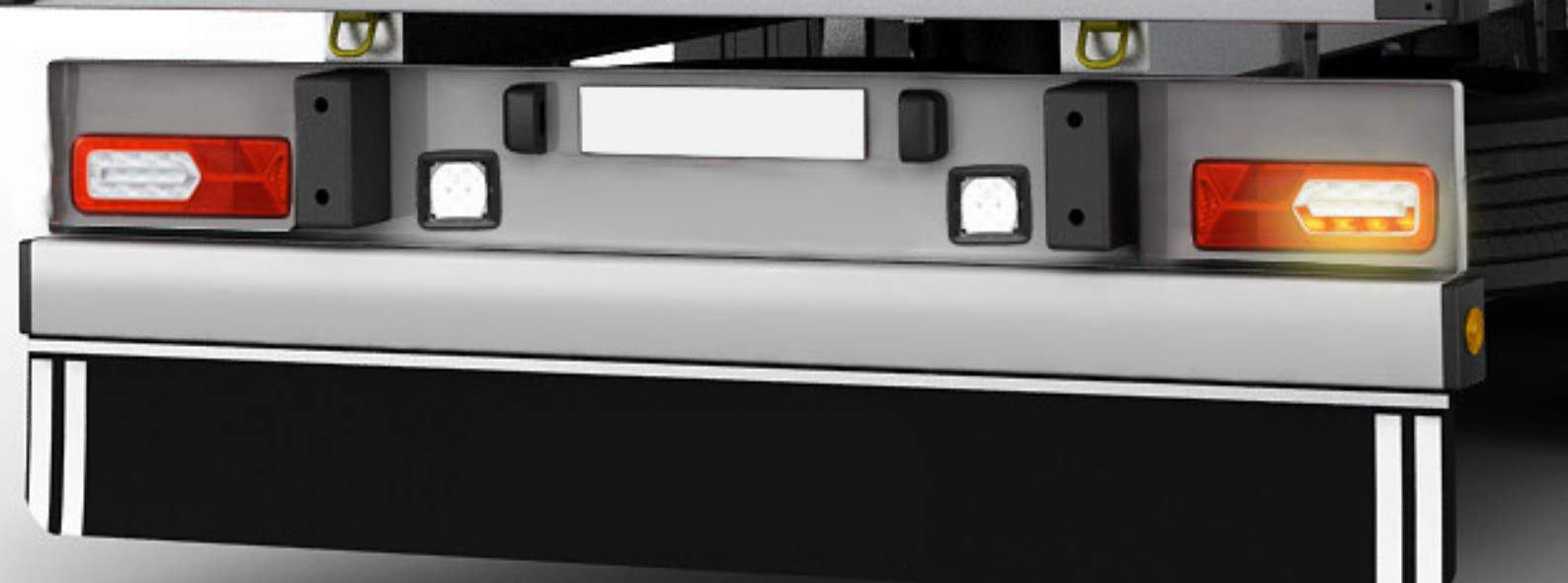

DT-2P-M

Type connecteur - Nb pins - Mâle ou Femelle  
Tipo di connettore - Num pin - Maschio o Femmina  
Tipo de conector - Num pines - macho o hembra



Flashez le QR code pour plus d'infos  
Scansiona il codice QR per maggiori informazioni  
Escanea el código QR para obtener más info



Pièces détachées  
Ricambi  
Repuestos



Numéro d'homologation  
Numero di omologazione  
Número de aprobación



Homologué ECE-R23  
Omologato ECE-R23  
Homologado ECE-R23



Faisceau p. 301  
Cablaggio p. 301  
Cableado p. 301



Vitre en verre trempé  
Lente in vetro temperato  
Tulipa de vidrio templado



Vitre en polycarbonate  
Lente in policarbonato  
Tulipa de policarbonato

## SL 1000 R23



**NEW**



DT-2P-M

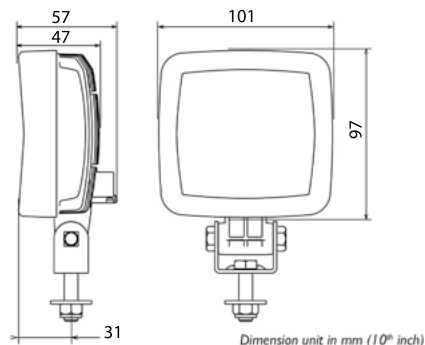

**D14857**  
(A0787A711300)

LED

12/24V  
14W

1000 Lumen

ADR

✓ R23 ✓ R10

E<sub>2</sub> 19140

IP69K

**NEW**



DT-2P-M



**D14880**  
(A0787A712400)

Aluminium

## RL 1500 R23



**NEW**



DT-2P-M

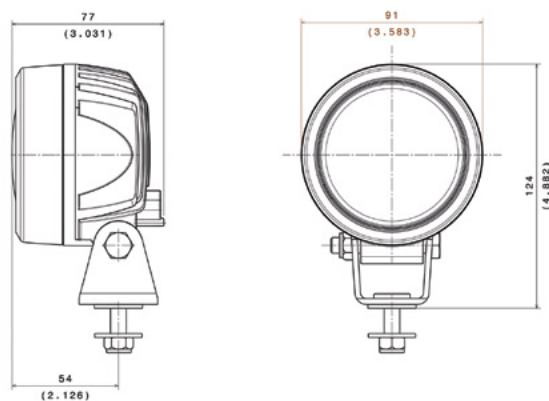

**D14858**  
(A0787A7395C3)

LED

12/24V  
20W

1500 Lumen

ADR

✓ R23 ✓ R10

E<sub>2</sub> 20078

IP69K

# Phares de recul - Fari retromarcia - Faros marcha atrás

## 2963 R23



**LED**

12/24V  
14W

1000 Lumen

✓ R23 ✓ R10

E11 7573

IP69K



**D14555**  
(29.63.L23.C0V) 1000 mm

**D14556\***  
(29.63.L21.CDV)



\* Interrupteur - interruttore - interruptor

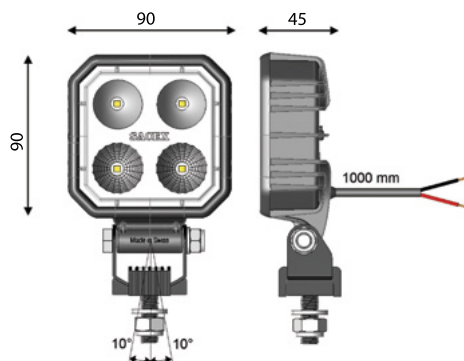

DT-2P-M



**D14759**  
(29.63.L23.CDV)

**NEW**

**D14811\***  
(29.63.L21.CDV)



\* Interrupteur - interruttore - interruptor

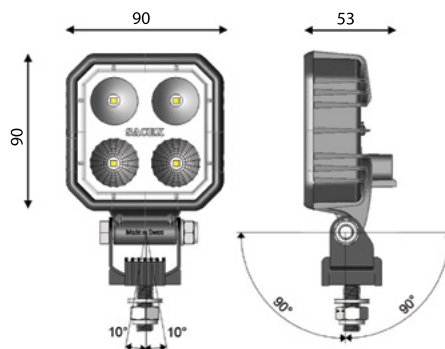

**D14170** DT-2P-F

## S H3 R23



H3/70W-24V

ADR

✓ R23

E2 R23-07089

IP69



DT-2P-M



**D12390\***  
(A0782A736900)

Interrupteur - interruttore - interruptor

\* lampe fournie - con lampadina - lampará incluida

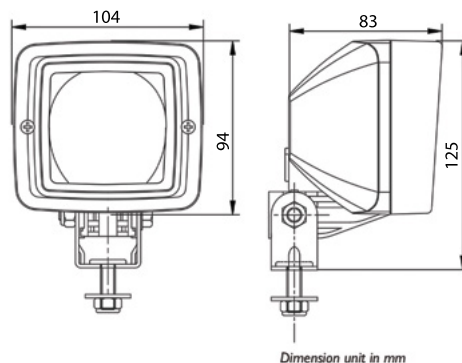

Dimension unit in mm

# Phares de travail

## Fari da lavoro

## Faros de trabajo



### LED

p. 222-235



### Halogene

p. 236-237



DT-2P-M

Type connecteur - Nb pins - Mâle ou Femelle  
Tipo di connettore - Num pin - Maschio o Femmina  
Tipo de conector - Num pines - macho o hembra



Flashez le QR code pour plus d'infos  
Scansiona il codice QR per maggiori informazioni  
Escanee el código QR para obtener más info



Pièces détachées  
Ricambi  
Repuestos



Faisceau p. 301  
Cablaggio p. 301  
Cableado p. 301



Vitre en verre trempé  
Lente in vetro temperato  
Tulipa de vidrio templado



Vitre en polycarbonate  
Lente in policarbonato  
Tulipa de policarbonato

# Phares de travail - Fari da lavoro - Faros de trabajo



 **OE Original Parts**



Nouveau! Éclaire plus loin et plus large  
 CEM CISPR25 Classe 5 (la plus haute protection électromagnétique) - Load dump intégré  
 Novità! Illumina ampiamente e più lontano  
 EMC CISPR25 Classe 5 (massima protezione elettromagnetica) - Load dump integrato  
 ¡Nuevo! Ilumina más lejo y más largo  
 CEM CISPR25 Clase 5 (máxima protección electromagnética) - Load dump integrado

## SL 1000



**NEW**



DT-2P-M

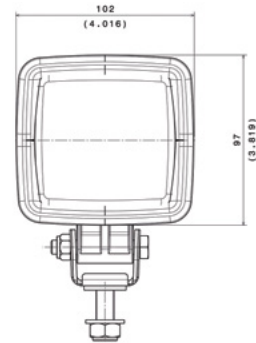
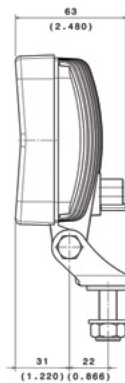

**LED**

 12/24V  
14W

 1000 Lumen

 **IP69K**

**D14970**  
(A0787A742300)

**NEW**



DT-2P-M

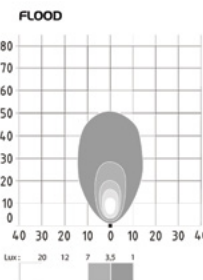

**D14850**  
(A0787A710700)

## SL 1500



**NEW**



DT-2P-M

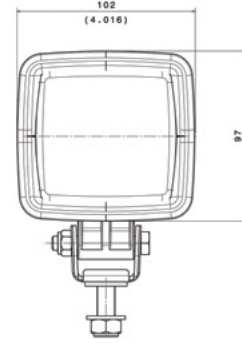
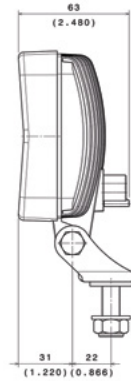

**LED**

12/24V  
20W

1500 Lumen

**IP69K**

**D14971**  
(A0787A742400)

**NEW**



DT-2P-M



**FLOOD**

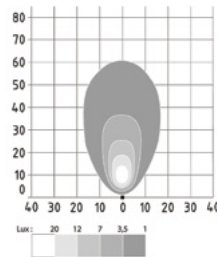

**D14851**  
(A0787A710800)

## SLA 2000



**NEW**



DT-2P-M

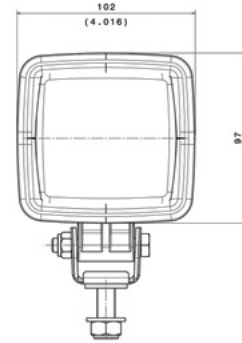
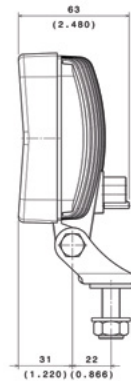

**LED**

12/24V  
29W

2000 Lumen

**IP69K**

**D14852**  
(A0787A710900)

Aluminium

**NEW**



DT-2P-M



**FLOOD**

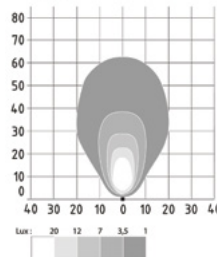

**D14856**  
(A0787A711700)

Aluminium



## SLA 2000 NO GLARE



**NEW**



DT-2P-M

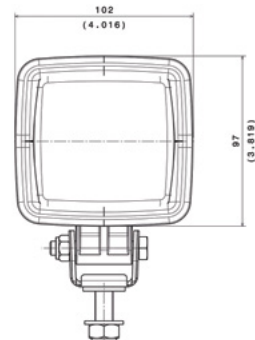
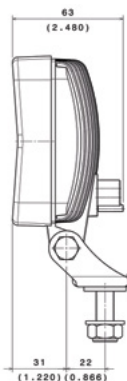

**LED**

12/24V  
29W

2000 Lumen

**IP69K**

**D14968**  
(A0787A7284C3)

Aluminium



N'éblouit ou n'aveugle pas - Éclaire la zone de travail  
Non acceca o abbaglia - illumina l'area di lavoro  
Sin cegamiento ni deslumbramiento: ilumina el área de trabajo



## RL 1000



**NEW**



DT-2P-M

LED

12/24V  
14W

1000 Lumen

IP69K

**D14853**  
(A0187A711000)

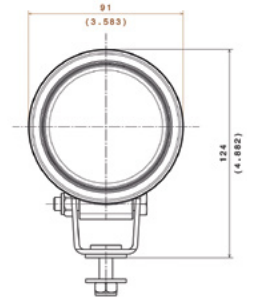
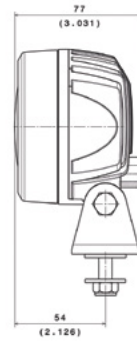
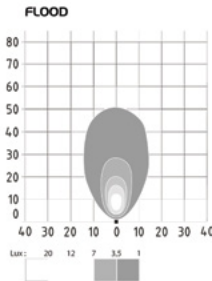

## RL 1500



**NEW**



DT-2P-M

LED

12/24V  
20W

1500 Lumen

IP69K

**D14854**  
(A0187A711100)

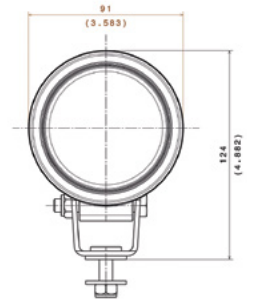
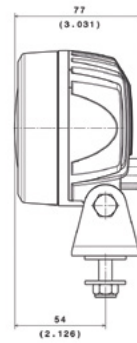
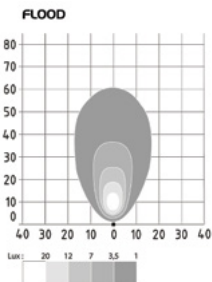

## RLA 2000



**NEW**



DT-2P-M

LED

12/24V  
29W

2000 Lumen

IP69K

**D14855**  
(A0187A711200)

Aluminium

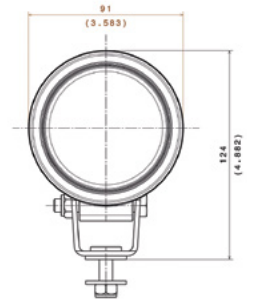
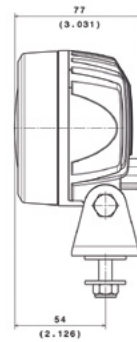
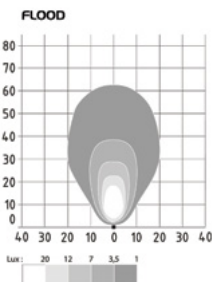

# Phares de travail - Fari da lavoro - Faros de trabajo

## OLA 1000



**NEW**



DT-2P-M

**LED**

12/24V  
14W

1000 Lumen

IP69K

**D14965**  
(A0487A7402C3)

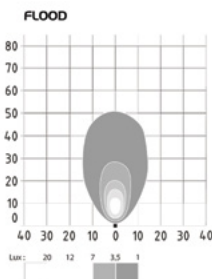

## OLA 1500



**NEW**



DT-2P-M

**LED**

12/24V  
20W

1500 Lumen

IP69K

**D14966**  
(A0487A7406C3)

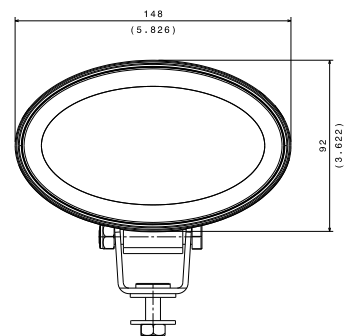
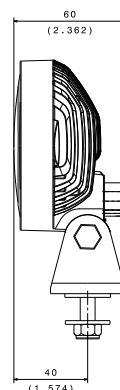
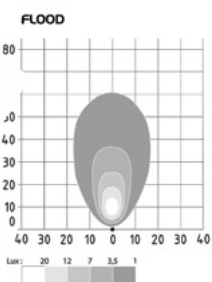

## OLA 2000



**NEW**



DT-2P-M

**LED**

12/24V  
29W

2000 Lumen

IP69K

**D14967**  
(A0487A7200C3)

Aluminium

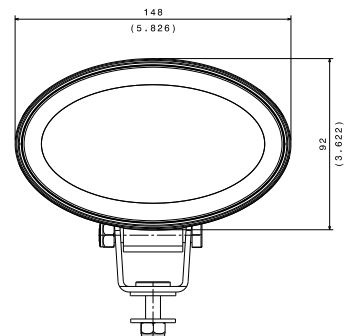
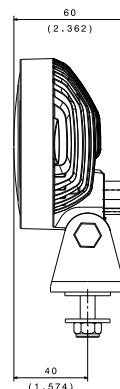
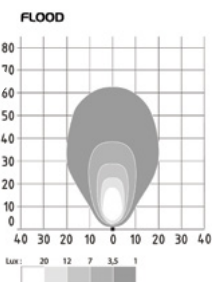

## SHD 1000



DT-2P-M

LED

9/36V  
11 W

1000 Lumen

IP69K

**D14160**  
(A0787A656800)

Aluminium

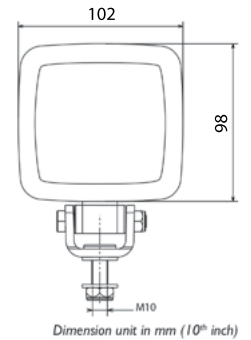
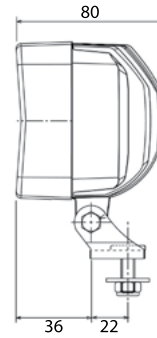
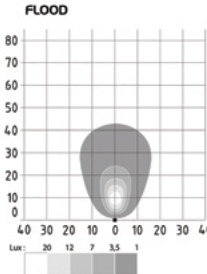

## SHD 1200



DT-2P-M

LED

9/36V  
20 W

1200 Lumen

IP69K

**D14161**  
(A0787A656900)

Aluminium

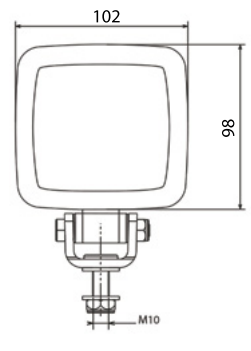
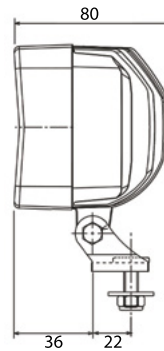
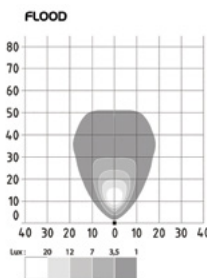

## SHD 3000



DT-2P-M

LED

12/24-100V  
38 W

3000 Lumen

IP69K

**D14447**  
(A0787A682200)

Aluminium

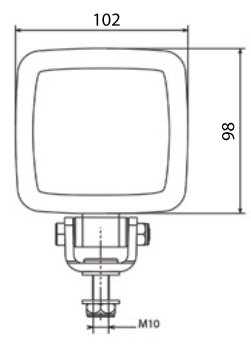
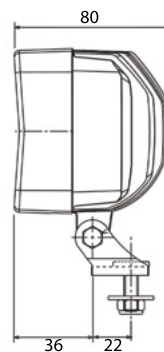
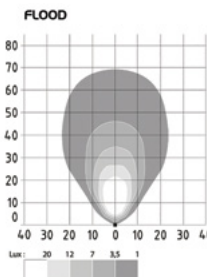

# Phares de travail - Fari da lavoro - Faros de trabajo

## SHD 5000

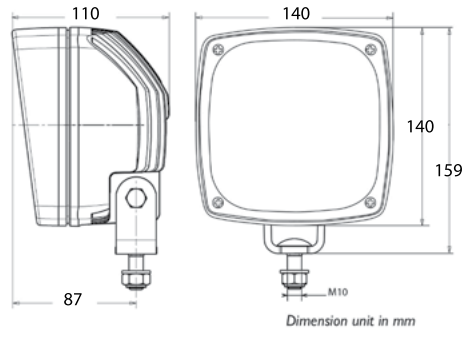

**LED**

12/24-100V  
57 W

5000 Lumen

**IP69K**

**D14387**  
(A0727A615900)  
Aluminium

## SHD 8000 LED

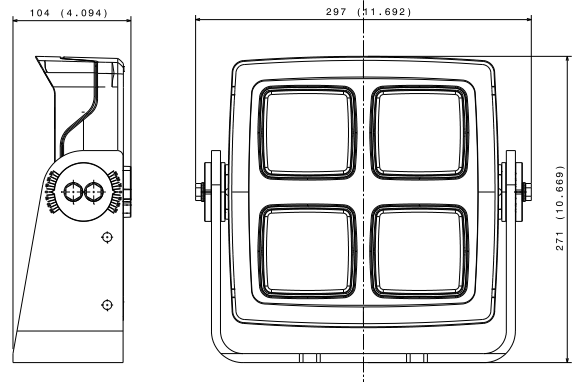

**LED**

12/24V  
90 W

8000 Lumen

**IP69K**

**Ref sur demande**  
P/N su richiesta - Ref. a petición



Feu de travail LED Heavy Duty modulaire  
Faro da lavoro modulare Heavy Duty LED  
Faro de trabajo modular Heavy Duty LED



Long range

Flood



Long range  
+ Indicator

Flood  
+ Stop



## BL15



LED

24V



E2 16007  
10R-0516079

Affectations constructeurs  
Applicazione primo impianto  
Afectación primer equipo

CHEREAU p. 19  
FRUEHAUF p. 35  
LECAPITAINE p. 65  
TROUILLET p. 123

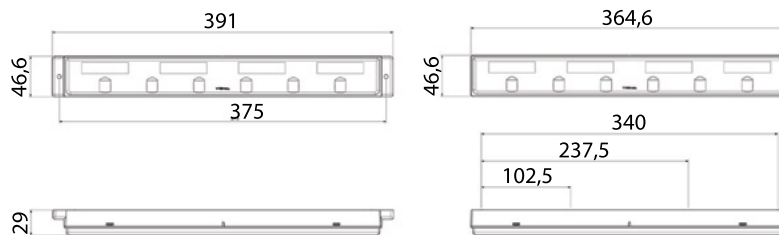

**165020**  
gauche - sinistra - izquierda



DT04-4P-M



DTM06-4S-4P-F

Fixation par l'arrière  
Fissaggio posteriore  
Fijación trasera



**165030**  
droit - destra - derecha



**165040**  
gauche - sinistra - izquierda

Fixation par l'avant  
Fissaggio frontale  
Fijación frontal



**165050**  
droit - destra - derecha



**D14436** DT06-4S-4P-F



**D14435** DTM04-4P-M

Indicateur de direction à défilement - feux de détresse flash  
Indicatore di direzione dinamico - luci di emergenza flash  
Intermitentes dinámicos - luces de emergencia flash

Feu de travail 1200 Lumen  
Faro da lavoro 1200 Lumen  
Faro de trabajo 1200 Lumen

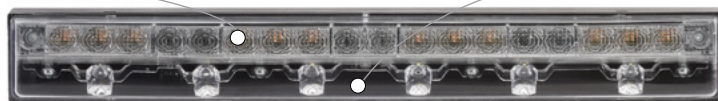

# CARBONLUX



COMPACT - COMPATTO - COMPACTO  
 LEGER - LEGGERO - LIGERO  
 TECHNO-RESINE CARBONE - RESINA CARBONIO - TECHNO-RESINA CARBONO  
 OPTIQUE DOUBLE - DOPPIA OTTICA - DOBLE OPTICO

## 2960



**D14540**  
 (29.60.L00.C0V) 1000 mm

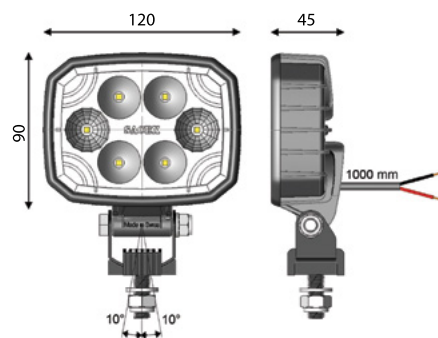

LED

10/30V  
 12 W

1500 Lumen

R10

IP69K



**D14541**  
 (29.60.L00.CDV)



DT-2P-M

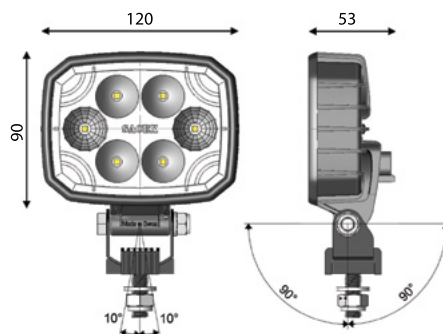

**D14170** DT-2P-F

## 2961



LED

10/30V  
12 W

1500 Lumen

R10

IP69K



**D14542**  
(29.61.L00.C0V) 1000 mm

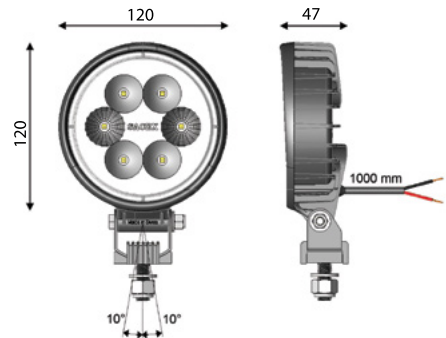

**D14543**  
(29.61.L00.CDV)



DT-2P-M

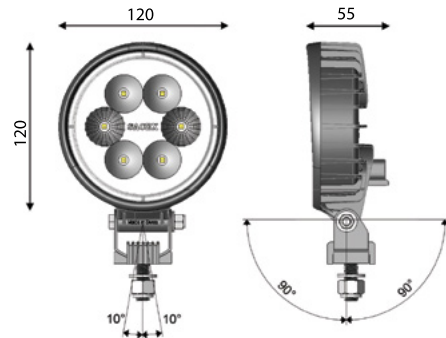

## 2962



LED

10/30V  
12 W

1500 Lumen

R10

IP69K



**D14544**  
(29.62.L00.C0V) 1000 mm

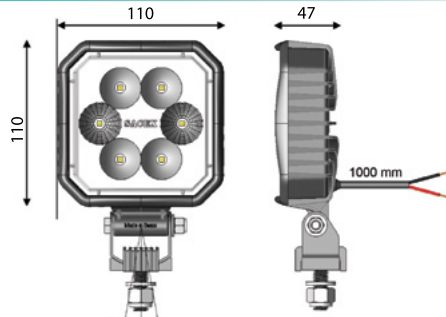

**D14545**  
(29.62.L00.CDV)



DT-2P-M

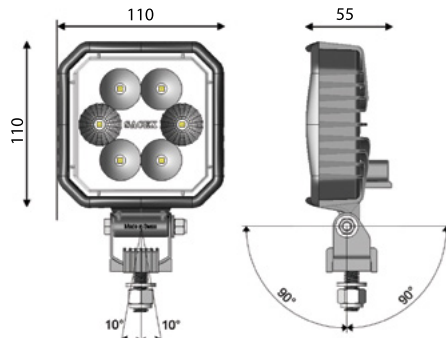

**D14546**  
(29.62.LV0.CDV)

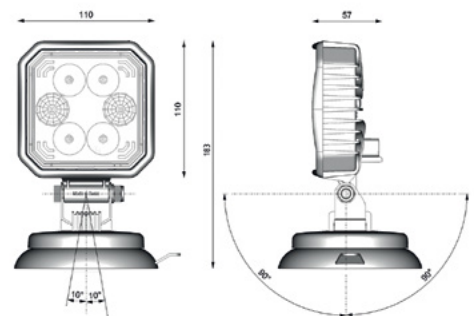



# Phares de travail - Fari da lavoro - Faros de trabajo

## 2963



**LED**

10/30V  
9 W

1000 Lumen

**R10**

**IP69K**

PC



**D14547**  
(29.63.L00.C0V) 1000 mm

PC



**D14552**  
(29.63.LA0.C0V) 1000 mm

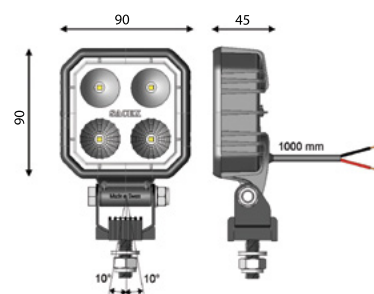

PC



**D14553**  
(29.63.L0A.C0V) 1000 mm

PC



**D14554**  
(29.63.LSB.C0V) 1000 mm



PC



**D14548**  
(29.63.L00.CDV)



DT-2P-M

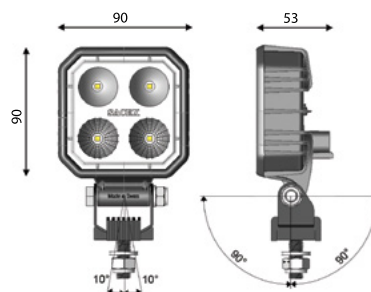

**D14170** DT-2P-F

## 2963



**LED**

10/30V  
9 W

1000 Lumen

**R10**

**IP69K**

\*Interrupteur - interruttore - interruptor

PC



**D14549 \***  
(29.63.LMI.COV) 1000 mm

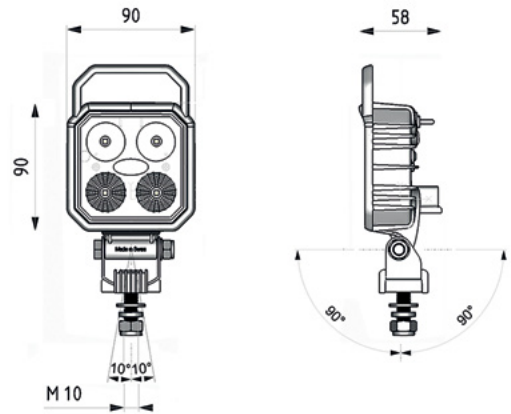

PC



**D14550 \***  
(29.63.LVX.CDV)

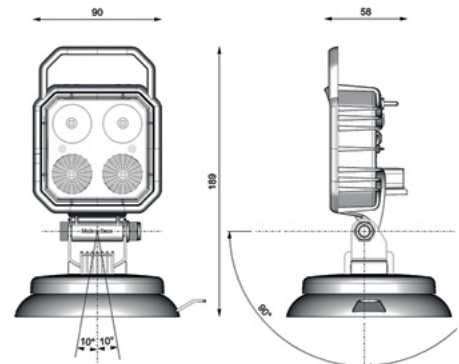

PC



**D14551 \***  
(29.63.L7X.COV)

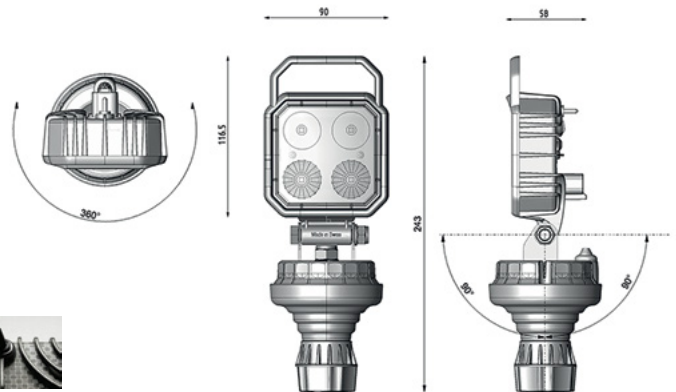

**D14514**

# Phares de travail - Fari da lavoro - Faros de trabajo

## 2964



LED

10/30V  
12 W

2000 Lumen

R10

IP69K

PC



**D14557**  
(29.64.L00.C0V) 1000 mm

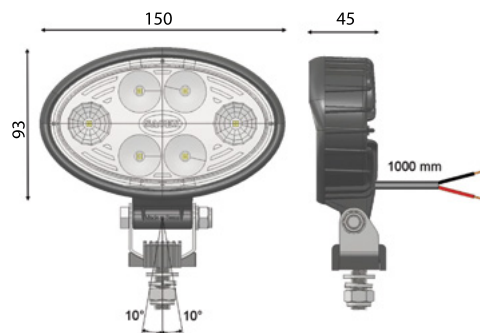

PC



**D14558**  
(29.64.LMI.C0V)



Interrupteur - interruttore - interruptor

## FTC



LED

12/24V  
15 W

850 Lumen

IP69



High power 100%  
Eco 30%  
Flash SOS



95 cm

**D14191**

batterie rechargeable  
batteria ricaricabile  
batería recargable

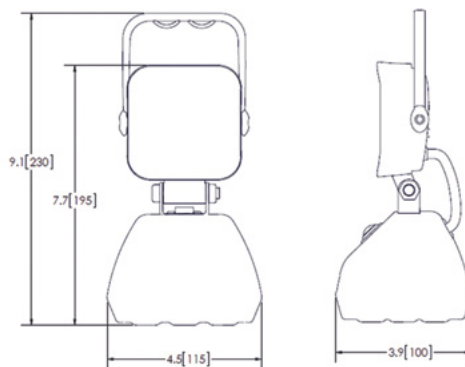

**D14192**  
prise adaptateur AC - CA adattatore - CA adaptador

## RC 850 LED



LED

10/30V  
12 W

1500 Lumen

R10

IP69K

**NEW**



**D14743** 1000 mm

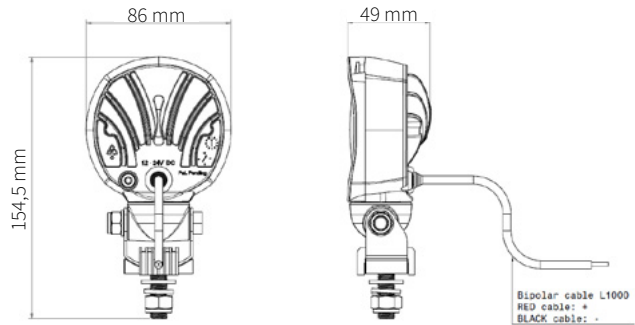

**NEW**



DT-2P-M

**D14744**

**NEW**

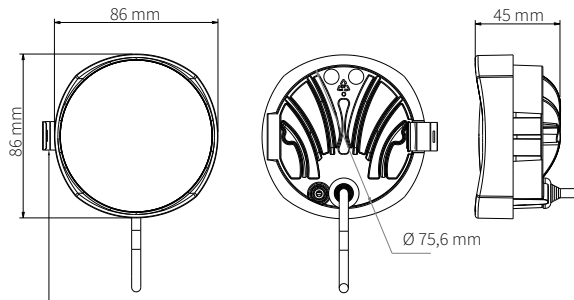

**D14745**

clippé - fissaggio con clip - fijación con clip



Compact (Ø 8,6 cm) et léger  
Compatto (Ø 8,6 cm) e leggero  
Compacto (Ø 8,6 cm) y ligero

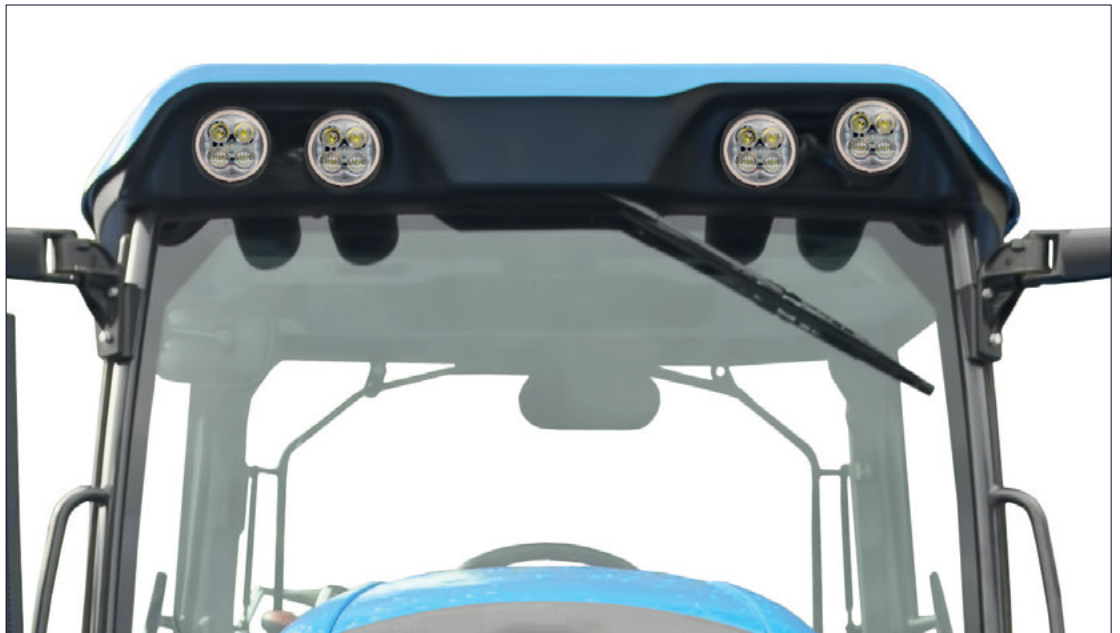

# Phares de travail - Fari da lavoro - Faros de trabajo

## Q H3



**H3/70W**  
12/24/36/48/80V



**DT-2P-M**



**D14159**  
(A0782A736500)

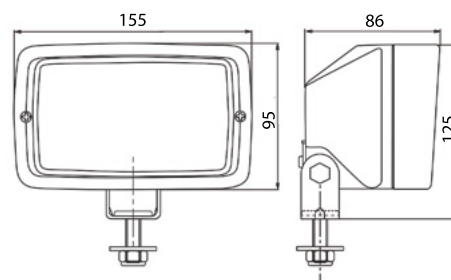

## R H3



**H3/70W**  
12/24/36/48/80V



**DT-2P-M**



**D14654**  
(A0166A736400)

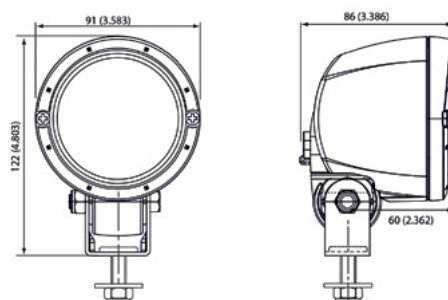

## S H3



**H3/70W-24V**  
**H3/35W-24V** ●



**DT-2P-M**



**D14156**  
(A0782A736500)

**D12488\***  
(A0782A736800) ●

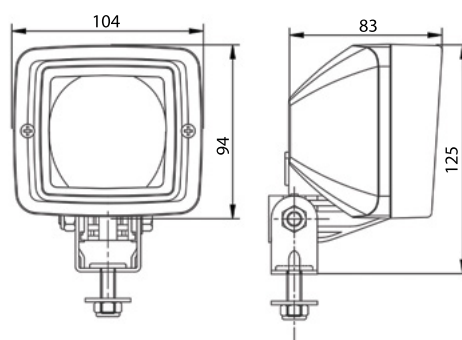

Dimension unit in mm

## S H3

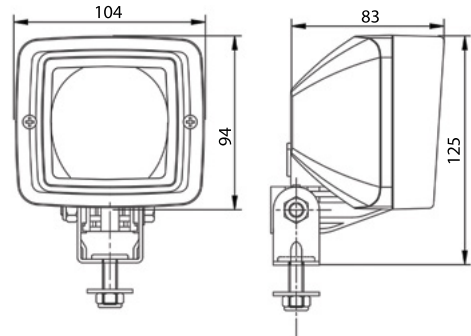

Dimension unit in mm

 H3/70W-24V

  
IP66

Affectations constructeurs  
Applicazione primo impianto  
Afectación primer equipo

[VOLVO TRUCKS p. 130](#)

**D12111\***  
(A0782A639700)

\* lampe fournie - con lampadina - lampará incluida

## S H3



DT-2P-M

 H3/70W-24V

  
IP66

Affectations constructeurs  
Applicazione primo impianto  
Afectación primer equipo

[RENAULT TRUCKS p. 89](#)  
[SCANIA p. 116](#)  
[VOLVO TRUCKS p. 134](#)

**D13019\***  
(A0782A563700)

\* lampe fournie - con lampadina - lampará incluida

# Éclairage de sécurité

## Luci di segnalazione

### Faros de advertancia



DT-2P-M

Type connecteur - Nb pins - Mâle ou Femelle  
Tipo di connettore - Num pin - Maschio o Femmina  
Tipo de conector - Num pines - macho o hembra



Vitre en verre trempé  
Lente in vetro temperato  
Tulipa de vidrio templado



Flashez le QR code pour plus d'infos  
Scansiona il codice QR per maggiori informazioni  
Escanee el código QR para obtener más info

# Éclairage de sécurité - Luci di segnalazione - Faros de advertancia

## SHD BLUE RED

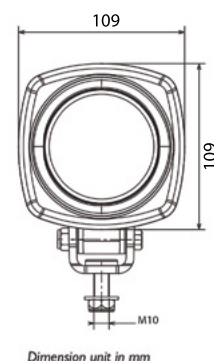
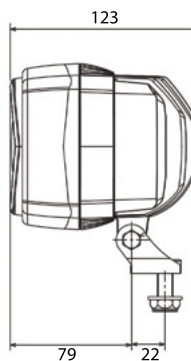

Dimension unit in mm

LED

12/24-100V  
5W

IP69



**D14249**  
(A0787A625500)



DT-2P-M

**D14653**  
(A0787A677400)



DT-2P-M

**D14250**  
(A0787A625600)



AMP-2P-M



## QL LED



SPOT OU FLECHE - SPOT O FRECCIA - PUNTO O FLECHA

LED

12/24-100V  
7W

IP69



**D14769**  
(A0737A702600)



DT-2P-M

**D14770**  
(A0737A702700)



**D14771**  
(A0737A702800)

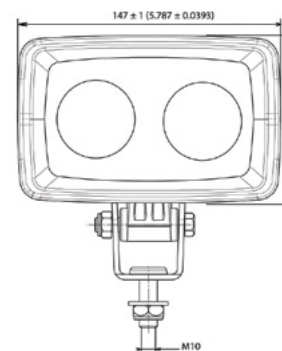
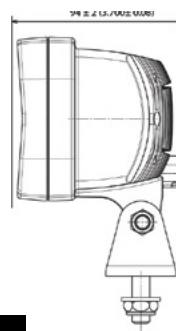
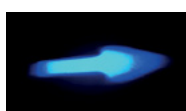

Dimension unit in mm (10<sup>th</sup> inc)

## WARNING LINE



COMPACT - COMPATTO - COMPACTO



LED

12/24-80V  
6W

IP67



**D14357**



**D14358**

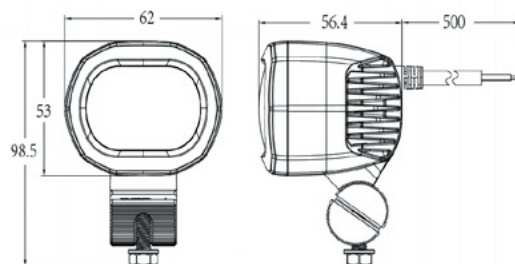



# Phares de conduite

## Proiettori

### Faros delanteros



**NEW**



DT-2P-M

Type connecteur - Nb pins - Mâle ou Femelle  
Tipo di connettore - Num pin - Maschio o Femmina  
Tipo de conector - Num pines - macho o hembra



Flashez le QR code pour plus d'infos  
Scansiona il codice QR per maggiori informazioni  
Escanee el código QR para obtener más info



Pièces détachées  
Ricambi  
Repuestos

## CHL 2 LED



LED

10/36V  
50W High Beam  
30W Low Beam

✓ ECE ✓ SAE

E R112 - R6 - R7

IP69K

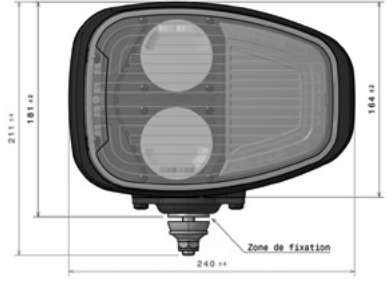
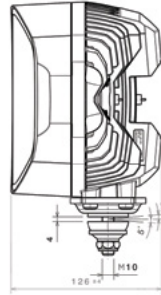

Feux de route - Feux de croisement - Indicateur de direction avant et latéral - Position  
Abbagliante - Anabbagliante - Indicatore di direzione anteriore e laterale - Posizione  
Luces de carretera - Luces de cruce - Intermitentes delanteros y laterales - Posición

**NEW**

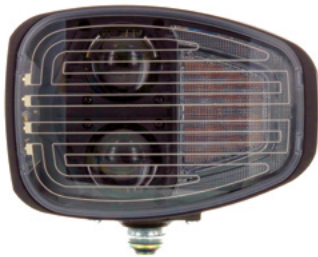

**D14964**  
(A0831A7333N3)

gauche - sinistra - izquierda



DT04-6P-M

**NEW**

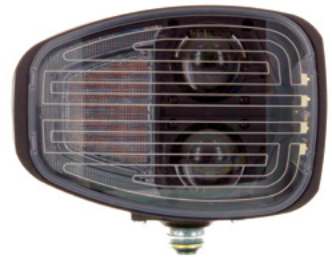

**D14963**  
(A0831A7332N3)

droit - destra - derecha



**D14352**  
(A87005182400)

DT04-6P-F



Nouveau! Technologie de dégivrage active et autonome  
Nuovo! Tecnologia antighiaccio attiva e autonoma  
¡Nuevo! Tecnología de deshielo activa y autónoma

✓ SAE



**Ref** sur demande  
P/N su richiesta - Ref. a petición

# Phares de conduite - Proiettori - Faros delanteros

## CHL 1 LED



LED



12/24V  
50W High Beam  
48W Low Beam



ECE



R112 - R6 - R7



IP69

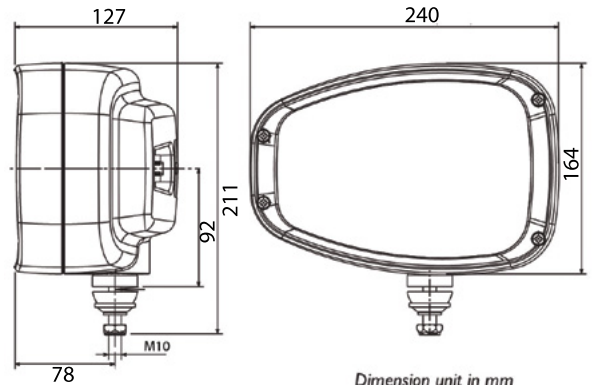

Feux de route - Feux de croisement - Indicateur de direction avant et latéral - Position  
Abbagliante - Anabbagliante - Indicatore di direzione anteriore e laterale - Posizione  
Luces de carretera - Luces de cruce - Intermitentes delanteros y laterales - Posición



**D14324**  
(A0831A673200)

gauche - sinistra - izquierda



**D14325**  
(A0831A673300)

droit - destra - derecha



**D14352**  
(A87005182400)

DT04-6P-F



SAE



**Ref sur demande**  
P/N su richiesta - Ref. a petición

## CHL1 H4

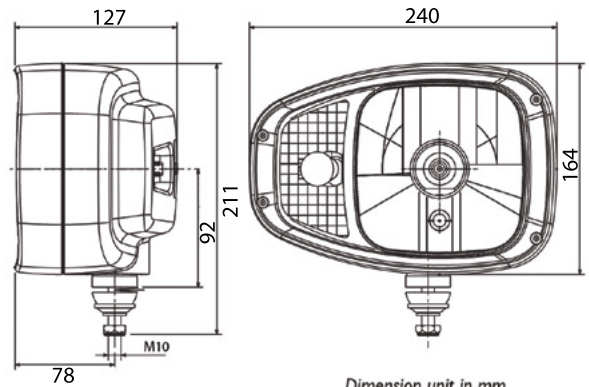
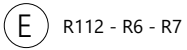

DT04-6P-M



**D14320**  
(A0830A673600) 12V

**D14322**  
(A0830A673400) 24V

gauche - sinistra - izquierda

**D14321**  
(A0830A673700) 12V

**D14323**  
(A0830A673500) 24V

droit - destra - derecha



**D14352**  
(A87005182400)

DT04-6P-F

## CL1 LED OFR



LED

12/24V



5W Low Beam OFF Road

3W Turn light

2W Pilot light



IP69

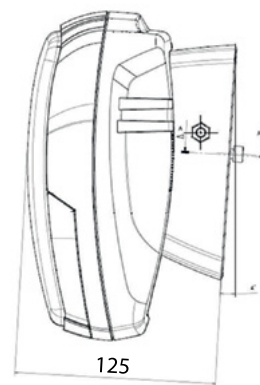
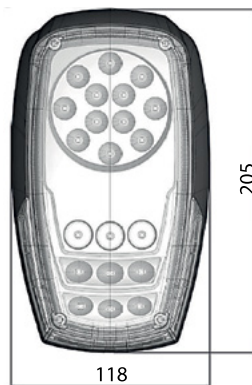

Feux de croisement - Indicateur de direction - Position  
Anabbagliante - Indicatore di direzione - Posizione  
Luces de cruce - Intermitentes - Posición



**D14649**  
(A0801A699800)

gauche - sinistra - izquierda



ECONOSEAL



**D14649**  
(A0801A699800)

droit - destra - derecha

# Feux auxiliaires

## Fari ausiliari

### Iluminación auxiliar



DT-3P-M

Type connecteur - Nb pins - Mâle ou Femelle  
Tipo di connettore - Num pin - Maschio o Femmina  
Tipo de conector - Num pines - macho o hembra



Flashez le QR code pour plus d'infos  
Scansiona il codice QR per maggiori informazioni  
Escanee el código QR para obtener más info

## ALPHA 175 LED



**NEW**



DT-3P-M

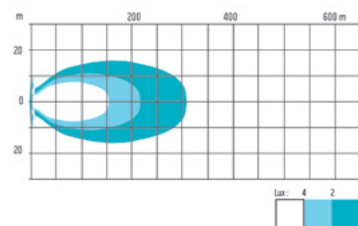
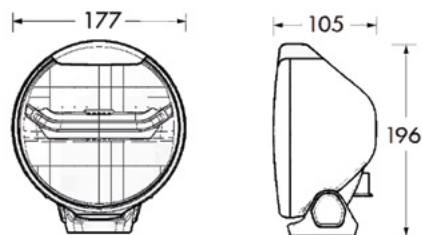

**LED**

10/33V  
35W High beam  
2,3W Position

4300 Lumen

\* connecteur fourni - con  
connettore - conector  
incluido

**D14167\***  
(A0342A699900)

## ALPHA 225 LED



**NEW**



DT-3P-M

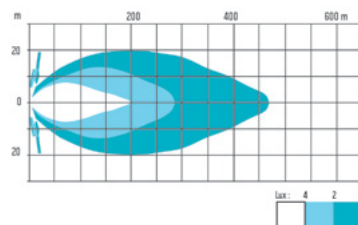
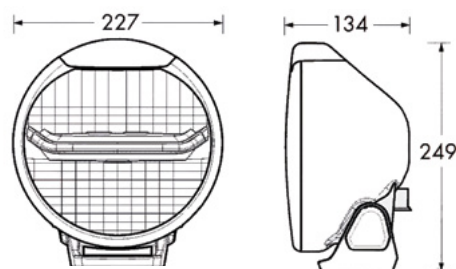

**LED**

10/33V  
50W High beam  
2,3W Position

6200 Lumen

\* connecteur fourni - con  
connettore - conector  
incluido

**D14993\***  
(A0332A745400)

## ALPHA 225 LED



DT-3P-M

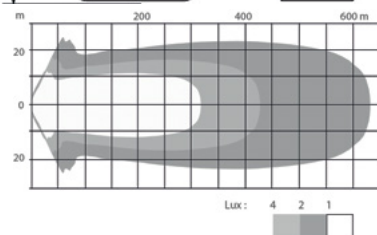
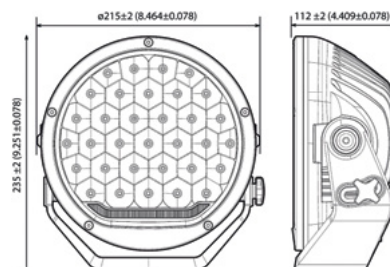

**LED**

10/33V  
150W High beam  
2,3W Position

8500 Lumen



**IP67**

\* connecteur fourni - con  
connettore - conector  
incluido

**D14673\***  
(A0342A699900)

## ALPHA 225 XENON



 35W-D1S GEN5  
24V  
43 W

 16903

\* lampe fournje - con lampadina - lamparà incluída

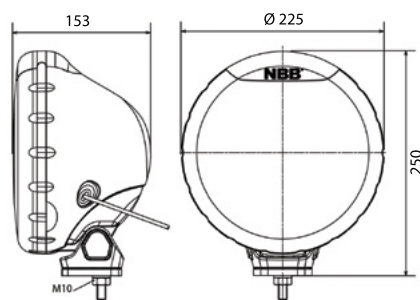

Dimension unit in mm

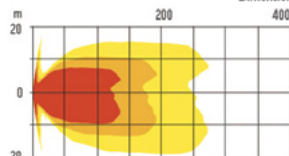

**D14165\***  
(A0331A657300)

## ALPHA 225



 H1-12/24V  
70W Max

 16902

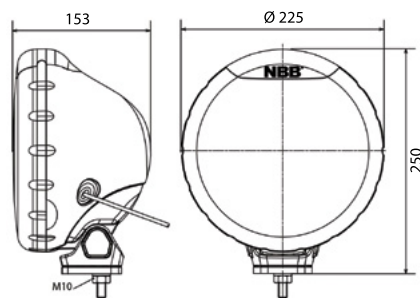

in mm

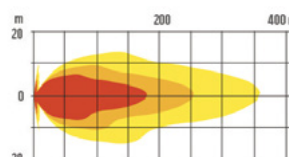

**D14166**  
(A0330A657400)



# Éclairage intérieur

## Illuminazione interna

## Iluminación interior



**NEW**



DT-2P-M

Type connecteur - Nb pins - Mâle ou Femelle  
Tipo di connettore - Num pin - Maschio o Femmina  
Tipo de conector - Num pines - macho o hembra



Flashez le QR code pour plus d'infos  
Scansiona il codice QR per maggiori informazioni  
Escanee el código QR para obtener más info



Pièces détachées  
Ricambi  
Repuestos

# Éclairage intérieur - Illuminazione interna - Iluminación interior

## 2250



LED

10-30V

R10

IP69

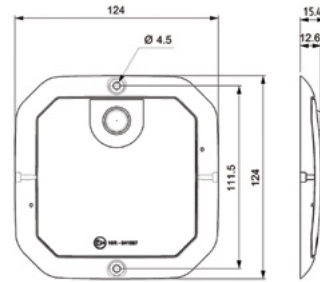
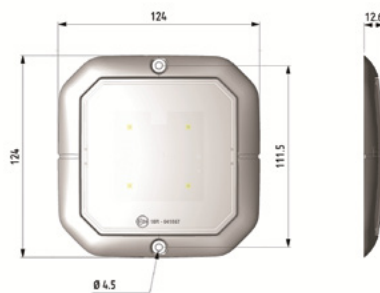

> 4 m <  
timer 5 min

500 Lumen

**D14569**  
(22.50.LP4.VLG) 4 LEDS - PIR

Avec détecteur de mouvement et chaleur (capteur PIR) - Con rilevatore di movimento e calore (PIR) - Con detector de movimiento y calor (PIR)



> 4 m <  
timer 5 min

500 Lumen

**MASTER**  
**D14598**  
(22.50.LP4.MSV) 4 LEDS - PIR

Avec détecteur de mouvement et chaleur (capteur PIR) - Con rilevatore di movimento e calore (PIR) - Con detector de movimiento y calor (PIR)



500 Lumen

**D14567**  
(22.50.L04.VLG) 4 LEDS

Sans détecteur de mouvement et chaleur (capteur PIR) - Senza rilevatore di movimento e calore (PIR) - Sin detector de movimiento y calor (PIR)



750 Lumen

**D14568**  
(22.50.L06.VLG) 6 LEDS

Sans détecteur de mouvement et chaleur (capteur PIR) - Senza rilevatore di movimento e calore (PIR) - Sin detector de movimiento y calor (PIR)

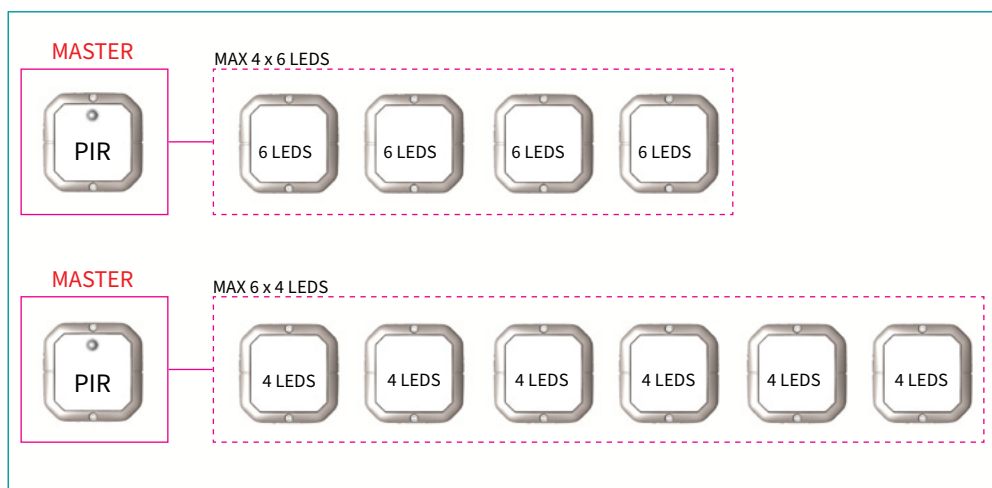

Exemple de montage Maître (PIR) + Esclaves -  
Esempio di montaggio Master (PIR) + Schiavi -  
Ejemplo de montaje Maestro (PIR) + Esclavos

## RCL 1200



LED

9-30V

1200 Lumen

R10

IP67

fils nus - estremità cavo nuda  
- cable pelado

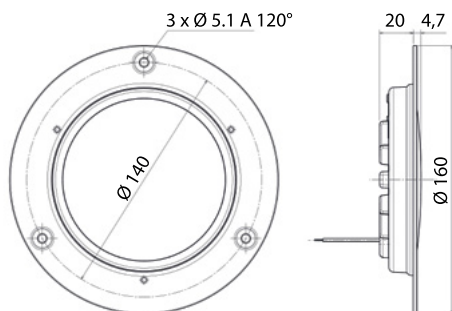

**NEW**



## FE02



W5W - 12/24V

ADR



E<sub>2</sub> 7102

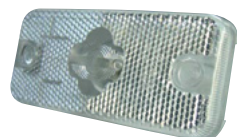
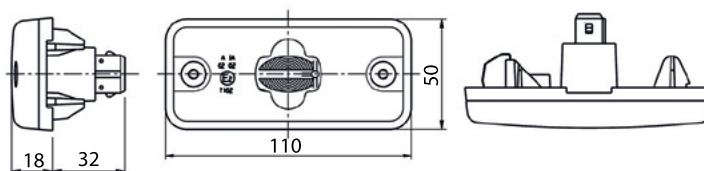

clippé - fissaggio con clip - fijación con clip



# Gyrophares

## Girofari

### Luces rotativas



## LED

p. 252-259



## Halogene

p. 260-263



 Montage sur tige  
Supporto tubolare DIN  
Montaje de DIN

 Fixation à visser  
Fissaggio a vite  
Fijación por tornillo

 Magnétique  
Magnético  
Magnético

 LED Rotatif  
LED Rotativo  
LED Giratorio

 LED à éclats  
LED Lampeggiante  
LED Flash

 Polycarbonate  
Policarbonato  
Policarbonato



Flashez le QR code pour plus d'infos  
Scansiona il codice QR per maggiori informazioni  
Escanee el código QR para obtener más info



Indice de protection IP - solides/liquides  
Protezione IP - solidi/liquidi  
Protección IP - sólidos/líquidos



Pièces détachées  
Ricambi  
Repuestos



Homologation circulation réseau routier public  
Omologazione circolazione su strada  
Homologación circulación por carretera



Homologation CEM - compatibilité électromagnétique  
Omologazione EMC - compatibilità elettromagnetica  
Homologación CEM - compatibilidad electromagnética



Accessoires p. 263  
Accessori p. 263  
Accesorios p. 263

# Gyrophares - Girofari - Luces rotativas

## ATLAS



LED

10/30V  
11 W - 17 W

✓ R65 ✓ R10

IP6K9K



Affectations constructeurs  
Applicazione primo impianto  
Afectación primer equipo

CLAAS p. 22  
DE BUF p. 29  
HYUNDAI CE p. 42  
MAN p. 70

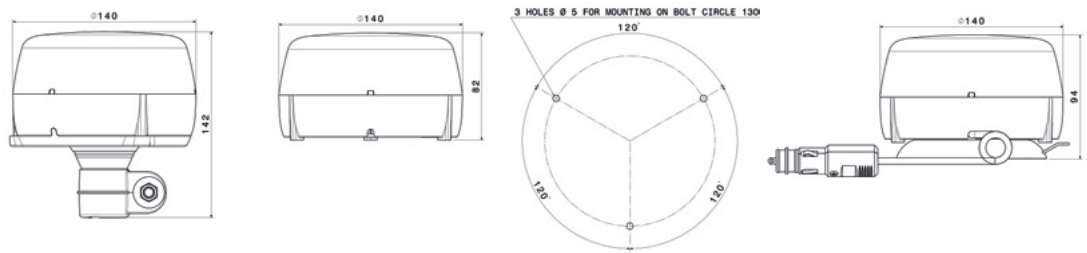

**NEW**



**212420**



**212460**



CEM Class 5

**212400**



CEM Class 3  
CLAAS p. 22

**212470**



CEM Class 5



**212120**



**212160**



filis nus - estremoità cavo nuda - cable pelado  
CEM Class 5

**212020**

CEM Class 5  
MAN p. 70



POS-2P-M



**212030**



CEM Class 5  
MAN p. 70

POS-2P-M



Feu de travail LED Heavy Duty modulaire  
Faro da lavoro modulare Heavy Duty LED  
Faro de trabajo modular Heavy Duty LED



**D13879**

POS-2P-F



## ATLAS



LED

10/30V  
11 W - 17 W

R65 R10

IP69



Affectations constructeurs  
Applicazione primo impianto  
Afectación primer equipo

MERCEDES p. 76  
RENAULT TRUCKS p. 86  
SAME p. 114  
VOLVO p. 130

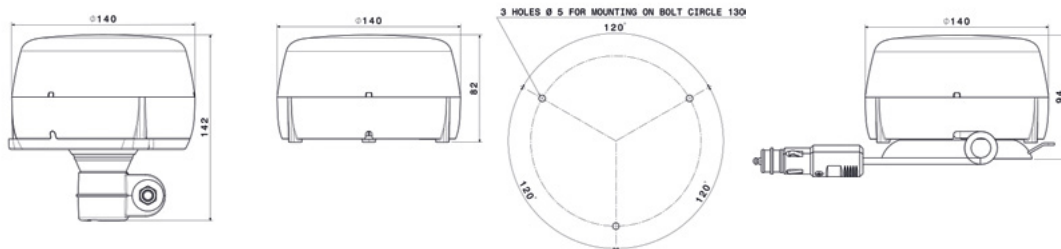

**NEW**



**212730**

CEM Class 5  
VOLVO p. 130



TYCO MCON-2P-M



**212170**

CEM Class 5  
fils nus - estremità cavo nuda - cable pelado



**NEW**



**212710**

CEM Class 5  
MERCEDES p. 76



MQS-2P-M



**212010**

CEM Class 4  
MERCEDES p. 76



KOSTAL-2P-M

**NEW**



**212740\***

CEM Class 5  
RENAULT TRUCKS p. 86



AMP-4P-F

**NEW**



**212750\***

CEM Class 5  
RENAULT TRUCKS p. 86



AMP-4P-F

\*212740 - 212750  
Disponibile en 09/2021  
Disponibile dal 09/2021  
Disponibile en 09/2021



**212520**



**212560**

CEM Class 5



**212570**

CEM Class 5



# Gyrophares - Girofari - Luces rotativas

## PEGASUS



LED

10/30V  
9 W

R65

R10



\* Multifunzione - Multifunción  
\*\* Rotativo - Giratorio

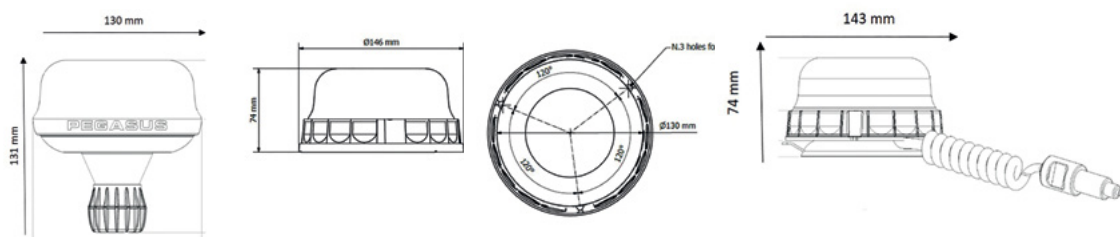

3 Types de flash homologués ECE R65  
3 tipi di flash omologati ECE R65  
3 tipos de flash homologadas ECE R65



FLASH



DOUBLE FLASH - DOPPIO FLASH - DOBLE FLASH

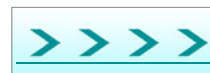

ROTATIF - ROTATIVO - GIRATORIO



FLEXI

**D14501**  
(21.50.L75.5V8) Multifonction\*

**D14725**  
(21.50.L75.3V8) Rotatif\*\*



**D14500**  
(21.50.L35.5V8) Multifonction\*

**D14724**  
(21.50.L35.3V8) Rotatif\*\*



**D14502**  
(21.50.LV5.5V8) Multifonction\*

**D14726**  
(21.50.LV5.3V8) Rotatif\*\*



**D14503**  
(21.50.811.MUV) Multifonction\*

cabochon - calotta - tulipa

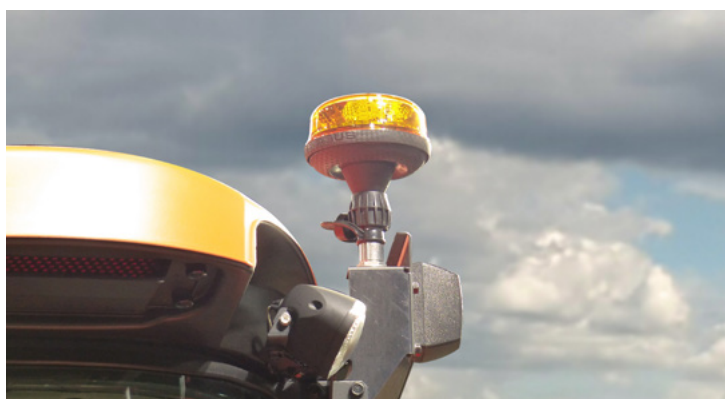

FLEXI

**D14757**  
(21.50.L75.51V) Multifonction\*



**D14756**  
(21.50.L35.51V) Multifonction\*



**D14758**  
(21.50.LV5.51V) Multifonction\*



**D14747**  
(21.50.201.MUV) Multifonction\*

cabochon - calotta - tulipa

## GALAXY LED



LED

10/30V  
9 W

✓ R65 ✓ R10

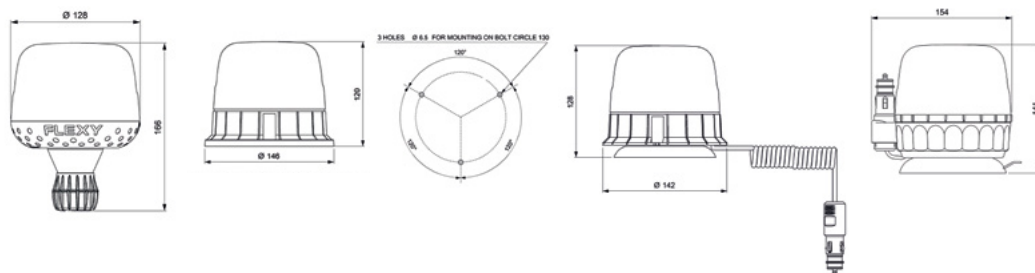

FLEXI

**D14488**  
(21.49.L75.3V8)



**D14487**  
(21.49.L35.3V8)



**D14489**  
(21.49.LV5.3V8)



**D14493**  
(21.49.L75.1V8)



**D14492**  
(21.49.L35.1V8)



**D14494**  
(21.49.LV5.1V8)



**D14490**  
(21.49.LR5.3V8)



**D14495**  
(21.49.LR5.1V8)



ROLL CABLE



**D14755**  
(21.49.LR5.11V)



ROLL CABLE



FLEXI

**D14753**  
(21.49.L75.11V)



**D14752**  
(21.49.L35.11V)



**D14754**  
(21.49.LV5.11V)



**D14491**  
(2149.815.RTV)



**D14496**  
(2149.815.LMV)



cabochon -calotta - tulipa



**D14779**  
(21.49.801.VLG)



cabochon -calotta - tulipa



# Gyrophares - Girofari - Luces rotativas

## VENUS LED

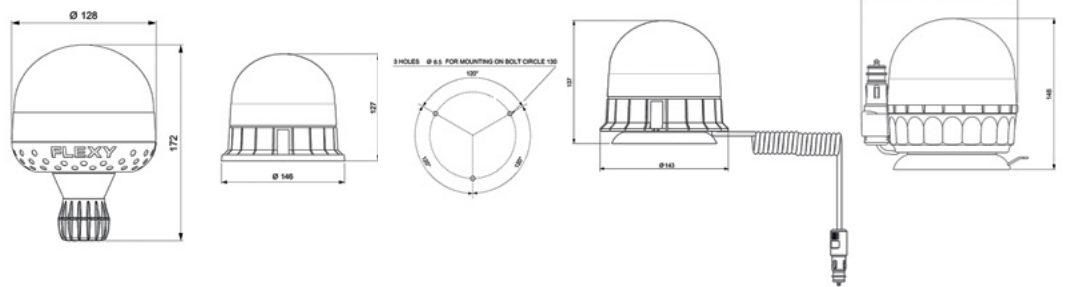

LED

10/30V  
9 W

✓ R65 ✓ R10



DOUBLE FLASH  
DOPPIO FLASH  
DOBLE FLASH



**D14728**  
(21.43.L75.2V8)



**D14727**  
(21.43.L35.2V8)



**D14729**  
(21.43.LV5.2V8)



**D14730**  
(21.43.LR5.2V8)



**D14731**  
(21.43.815.VLG)

cabochon - calotta - tulipa

## VEGA LED

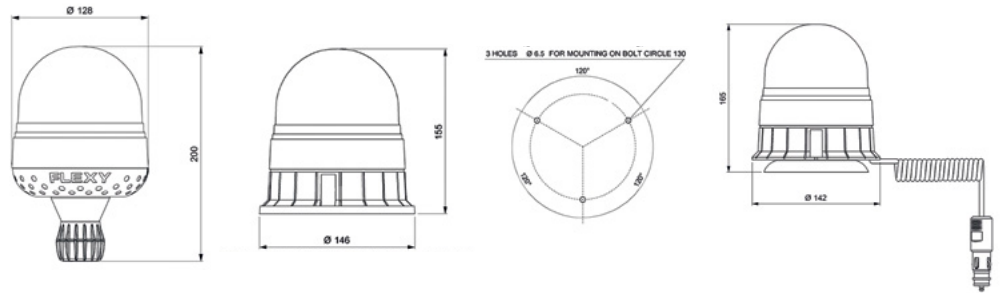

LED

10/30V  
9 W

✓ R65 ✓ R10



**D14508**  
(21.87.L75.3V8)



**D14507**  
(21.87.L35.3V8)



**D14509**  
(21.87.LV5.3V8)



**D14510**  
(21.87.815.RTV)

cabochon - calotta - tulipa

## TAURUS LED



LED

10/30V  
9 W

✓ R65 ✓ R10

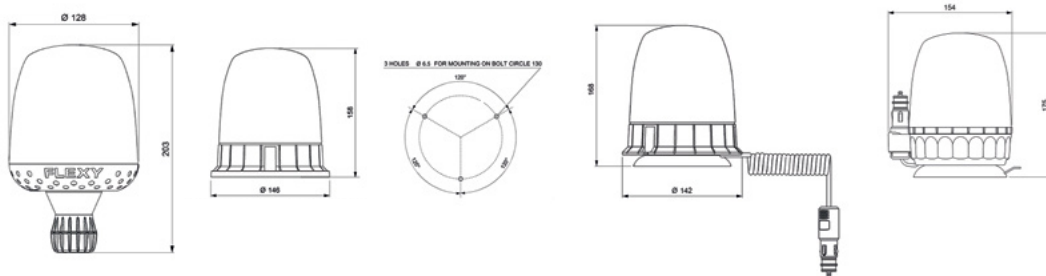

FLEXI

**D14483**  
(21.48.L75.3V8)



**D14482**  
(21.48.L35.3V8)



**D14485**  
(21.48.LV5.3V8)



**D14484**  
(21.48.LR5.3V8)



ROLL CABLE



**D14734**  
(21.48.LR5.15V)



ROLL CABLE



FLEXI

**D14733**  
(21.48.L75.15V)



**D14732**  
(21.48.L35.15V)



**D14735**  
(21.48.LV5.15V)



**D14486**  
(2148.815.RTV)

cabochon - calotta - tulipa



**D14736**  
(2148.855.LMV)

cabochon - calotta - tulipa

## SATURNELLO LED



LED

10/30V  
9 W

✓ R65 ✓ R10

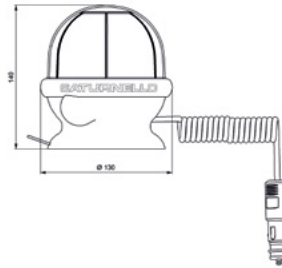
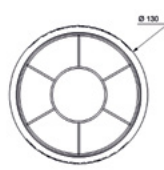

FLEXI

**D14737**  
(21.88.L85.3V8)



**D14738**  
(21.88.LV5.3V8)



**D14739**  
(21.88.815.VLG)

cabochon - calotta - tulipa

## MINI SATURNELLO LED



LED

10/30V  
9 W

✓ R65 ✓ R10

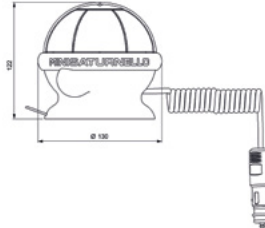

FLEXI

**D14740**  
(21.83.L85.3V8)



**D14741**  
(21.83.LV5.3V8)



**D14742**  
(21.83.815.VLG)

cabochon - calotta - tulipa

## PUCK



LED

10/30V  
3,5 W

R10

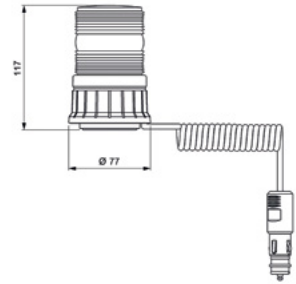
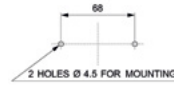
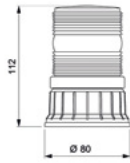
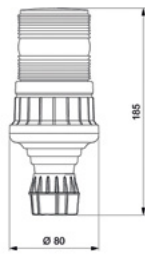

FLEXI

**D14453**  
(21.38.L75.2VL)



**D14451**  
(21.38.L35.2VL)



**D14452**  
(21.38.LM5.2VL)



COMPACT - COMPACTO



## FRESNEL



LED

10/110V  
3,5 W

R10

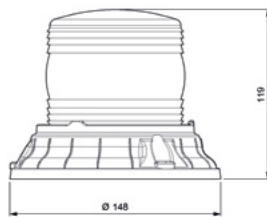

N°3 HOLES Ø 6.5 FOR MOUNTING ON BOLT CIRCLE 130

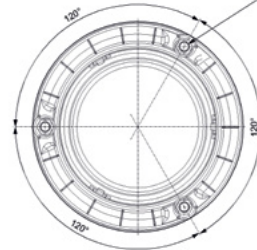

**D14746**  
(21.37.L35.2VL)

# Gyrophares - Girofari - Luces rotativas

## GALAXY



H21W



12/24V  
23W



lampes 12/24V fournies - con  
lampadine 12/24V - lamparás  
incluidas 12/24V

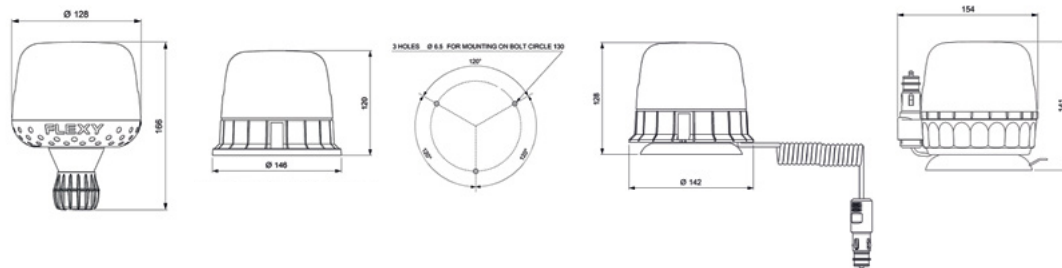

FLEXI

**D14749**  
(21.49.H75.VLG)



**D14748**  
(21.49.H35.VLG)



**D14750**  
(21.49.HV5.VLG)



**D14751**  
(21.49.HR5.VLG)



ROLL CABLE



**D14778**  
(21.49.811.VLG)

cabochon - calotta - tulipa

## VENUS



H21W



12/24V  
23W



lampes 12/24V fournies - con  
lampadine 12/24V - lamparás  
incluidas 12/24V

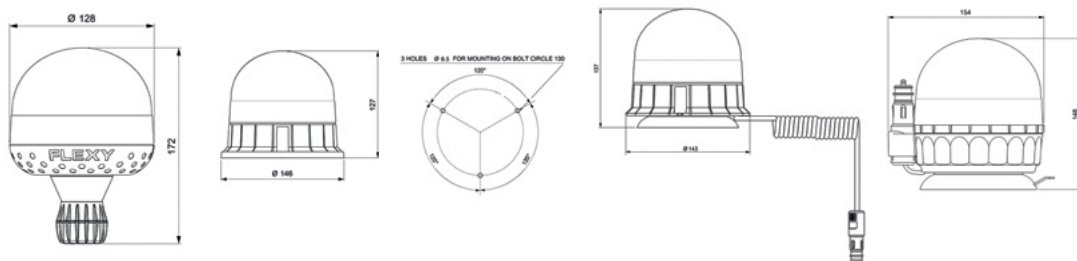

FLEXI

**D14463**  
(21.43.H65.VLG)



**D14462**  
(21.43.H35.VLG)



**D14464**  
(21.43.HV5.VLG)



**D14465**  
(21.43.HR5.VLG)



ROLL CABLE



**D14466**  
(21.43.811.VLG)

cabochon - calotta - tulipa

## TAURUS



H21W

12/24V  
23W



lampes 12/24V fournies - con lampadine 12/24V - lamparás incluidas 12/24V

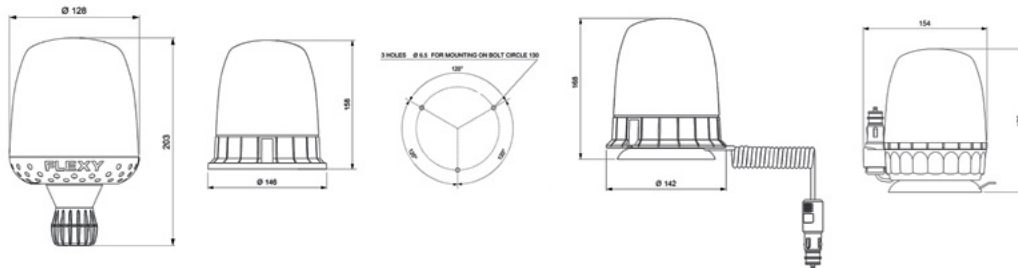

FLEXI

**D14470**  
(21.48.H75.VLG)



**D14467**  
(21.48.H35.VLG)



**D14468**  
(21.48.HV5.VLG)



**D14469**  
(21.48.HR5.VLG)



ROLL CABLE



**D14471**  
(21.48.811.VLG)

cabochon - calotta - tulipa

## VEGA



H1

12/24V  
55-70W



lampes 12/24V fournies - con lampadine 12/24V - lamparás incluidas 12/24V

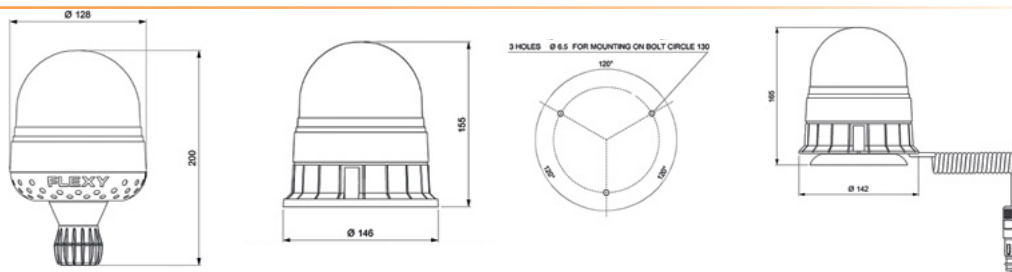

**D14479**  
(21.87.T75.VLG)



**D14477**  
(21.87.T35.VLG)



**D14478**  
(21.87.TV5.VLG)



**D14480**  
(21.87.811.VLG)

cabochon - calotta - tulipa

# Gyrophares - Girofari - Luces rotativas

## SATURNE



H1



12/24V  
55-70W



lampes 12/24V fournies - con  
lampadine 12/24V - lamparás  
incluidas 12/24V



FLEXI

**D14475**  
(21.82.T85.VLG)

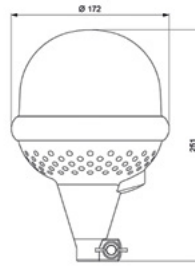

**D14476**  
(21.82.811.VLG)

cabochon - calotta - tulipa

## GOUTTE



10/30V  
9 W



**D14481**  
(21.35.LMV.358)

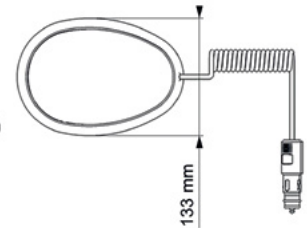
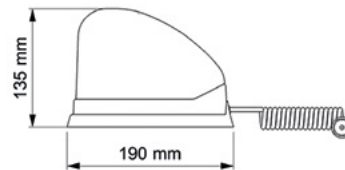

H1



12V



**D14454**  
(21.35.010.TVL)



**D14455**  
(21.35.050.TVL)



**D14456**  
(21.35.811.VLG)

cabochon - calotta - tulipa



**D14457**  
(21.35.851.VLG)

cabochon - calotta - tulipa



Exemple de montage - Esempio di montaggio - Ejemplo de montaje



**D14514**  
(21.92.000.VLG)

tige avec support central - supporto con staffa centrale - varilla con soporte central  
ISO 4148/4165



**D14513**  
(21.91.000.VLG)

tige à visser - supporto da avvitare - varilla para atornillar  
ISO 4148/4165

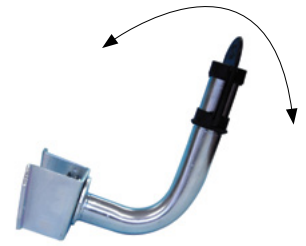

**D14515**  
(21.97.005.VLG)

tige articulée 360° - supporto orientabile 360° - varilla rotativa 360°  
ISO 4148/4165



**D14511**  
(21.76.282.VLG)

semelle plate - base piatta - base plana



**D14512**  
(21.76.283.VLG)

semelle inclinée - base inclinata - base inclinada



Exemple de montage - Esempio di montaggio - Ejemplo de montaje



**D14565** H21W 12V BAY9s  
(90.16.025.VLG)

**D14566** H21W 24V BAY9s  
(90.16.026.VLG)



# Rampes lumineuses

## Barre di segnalazione

## Puentes luminosos



**NEW**

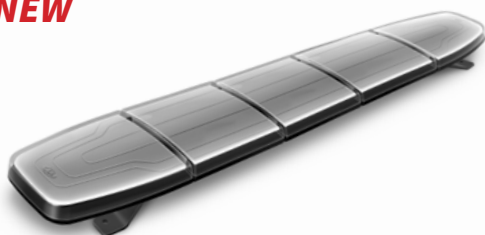

 Fixation à visser  
Fissaggio a vite  
Fijación por tornillo

 Magnétique  
Magnetico  
Magnético

 Polycarbonate  
Policarbonato  
Policarbonato



Flashez le QR code pour plus d'infos  
Scansiona il codice QR per maggiori informazioni  
Escanee el código QR para obtener más info



Indice de protection IP - solides/liquides  
Protezione IP - solidi/liquidi  
Protección IP - sólidos/líquidos



Pièces détachées  
Ricambi  
Repuestos



Homologation circulation réseau routier public  
Omologazione circolazione su strada  
Homologación circulación por carretera



Homologation CEM - compatibilité électromagnétique  
Omologazione EMC - compatibilità elettromagnetica  
Homologación CEM - compatibilidad electromagnética

## STELLAR



LED

10/36V

✓ R65

✓ R10

✓ SAE



IP66K9K

**NEW**

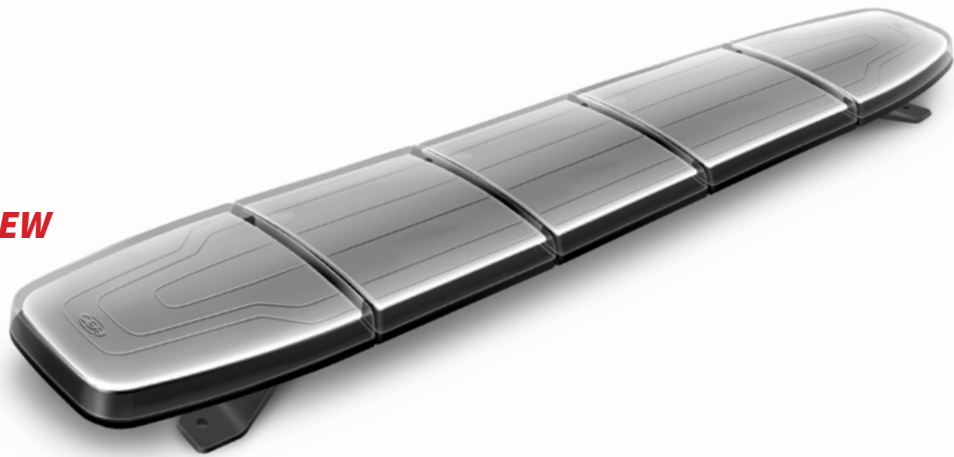

Modulaire et extra-plat - Circuit électronique plat - aucun câble intérieur  
Modulare e ultrapiatto - PCB piatto - senza cavi interni  
Modular y extraplano - PCB plana - sin cables internos



# Rampes lumineuses - Barre di segnalazione - Puentes luminosos

## STELLAR



**NEW**

**LED**



10/36V



**IP6K9K**

Câble fils nus - estremità cavo nuda - cable pelado

\* partie centrale opaque pour lettrages - parte centrale opaca per scritte - parte central opaca para marcado



**D23300\***  
(2370R35050)

950 mm



**D23301**  
(2370R35000)

950 mm

-> Petits véhicules utilitaires, voirie  
-> Auto e furgoncini  
-> Furgonetas ligeras o vehículos comunitarios



**D23400\***  
(2371R35050)

1250 mm



**D23401**  
(2371R35000)

1250 mm

-> Véhicules utilitaires, voirie  
-> Furgoni  
-> Furgonetas o vehículos comunitarios



**D23500\***  
(2372R35055)

1550 mm



**D23501**  
(2372R35000)

1550 mm

-> Camions (3,5t à 19t)  
-> Camion (3,5t a 19t)  
-> Camiones (3,5t a 19t)



**D23600\***  
(2373R35005)

1850 mm

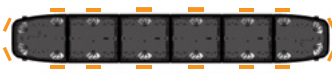

**D23601**  
(2373R35000)

1850 mm

-> Camions (19t à 44t)  
-> Camion (19t a 44t)  
-> Camiones (19t a 44t)



### Autres options et versions disponibles sur demande :

- Bleu véhicules prioritaires et d'urgences
- Phares de travail avant, arrière, latéraux
- Rappel stop, position, indicateur de direction
- Traffic master
- Interface véhicule mécanique et électronique

### Altre opzioni e versioni disponibili su richiesta:

- Veicoli prioritari e di emergenza
- Fari da lavoro anteriori, posteriori, laterali
- Fanale stop, posizione, indicatore di direzione
- Modulo sequenziale posteriore
- Interfaccia veicolo meccanica ed elettronica

### Otras opciones y versiones disponibles bajo pedido :

- Vehículos de emergencia y prioritarios
- Faros de trabajo y proyector delanteros, traseros, laterales
- Stop adicional, posición, intermitente
- Control del tráfico
- Interfaz de vehículo mecánica y electrónica

# Rampes lumineuses - Barre di segnalazione - Puentes luminosos

## MULTILED



LED

10/30V  
18 W

✓ R65 ✓ R10

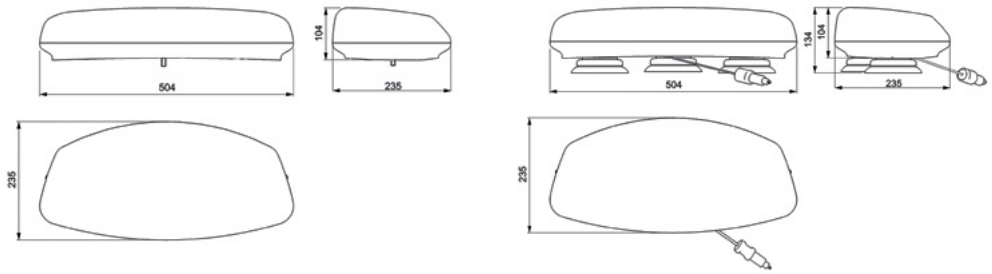

3 Types de flash homologués ECE R65  
3 tipi di flash omologati ECE R65  
3 tipos de flash homologadas ECE R65



FLASH



DOUBLE FLASH - DOPPIO FLASH - DOBLE FLASH



ROTATIF - ROTATIVO - GIRATORIO



**D14504**  
(23.51.L05.5V8)



**D14505**  
(23.51.LM5.5V8)



**D14506**  
(23.51.811.VLG)

cabochon - calotta - tulipa



## MULTILUX



H1

12/24V

✓ R65 ✓ R10



lampes 12/24V fournies - con lampadine 12/24V - lamparás incluidas 12/24V

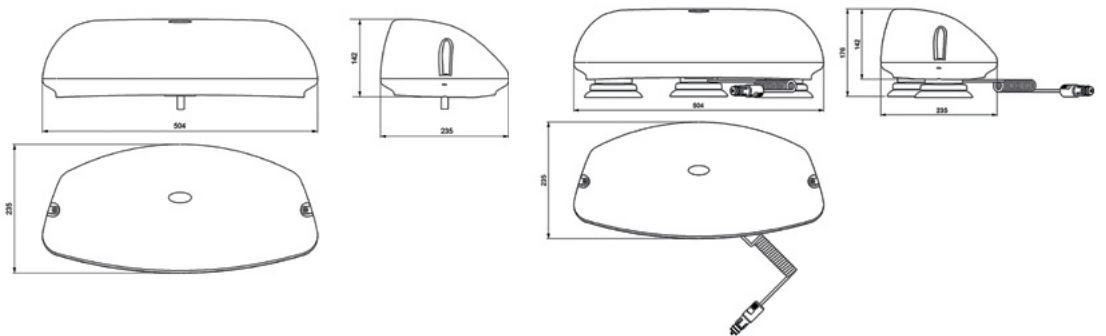

**D14472**  
(2350.03T.PVL)



**D14473**  
(2350.M3T.PVL)



**D14474**  
(2350.811.VLG)

cabochon - calotta - tulipa



# Triflash



LED à éclats  
LED Lampeggiante  
LED Flash



Polycarbonate  
Policarbonato  
Policarbonato



Pièces détachées  
Ricambi  
Repuestos



Flashez le QR code pour plus d'infos  
Scansiona il codice QR per maggiori informazioni  
Escanee el código QR para obtener más info



Indice de protection IP - solides/liquides  
Protezione IP - solidi/liquidi  
Protección IP - sólidos/liquidos



Homologation circulation réseau routier public  
Omologazione circolazione su strada  
Homologación circulación por carretera



Homologation CEM - compatibilité électromagnétique  
Omologazione EMC - compatibilità elettromagnetica  
Homologación CEM - compatibilidad electromagnética

# TRIFLASH 500



LED

10/30V  
9,5 W

R10

PC/ABS

IP6K9K

< 3,5t



\* kit de relevage manuel inclus - Sollevamento manuale incluso - Elevador manual incluido

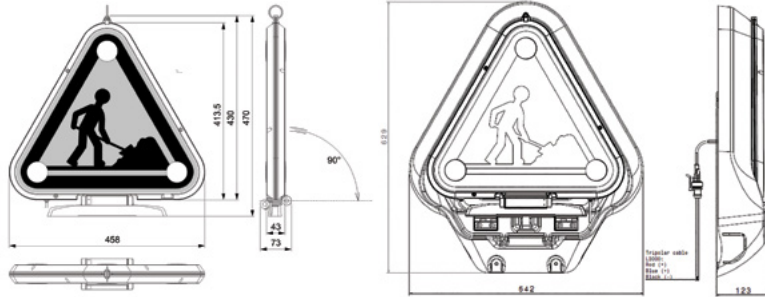

Symbole AK5 - Compact - Léger (3,15 Kg) - Homologué  
Simbolo AK5 - Compatto - Leggero (3,15 Kg) - Omologato  
Símbolo AK5 - Compacto - Ligero (3,15 Kg) - Homologado



**D14760 \***  
(2090L51200)



Classe 1 : ville et route nationale - strade urbane - Ciudad y carreteras nacionales



**D14762 \***  
(2090L52200)



Classe 2 : autoroutes et voies rapides - strade extraurbane - autovías

**NEW**

ELEC



**D14925**  
(2090L5220E)



Classe 2 : autoroutes et voies rapides - strade extraurbane - autovías

# TRIFLASH 700



LED

10/30V  
9,5 W

R10

PC/ABS

IP6K9K

> 3,5t



\* kit de relevage manuel inclus - Sollevamento manuale incluso - Elevador manual incluido

**NEW**



**D14926 \***  
(2090L72200)



Classe 2 : autoroutes et voies rapides - strade extraurbane - autovías

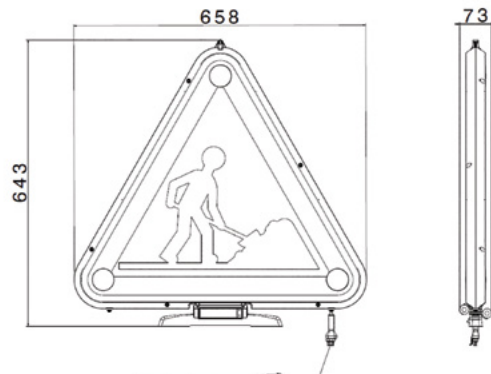

## TRIFLASH ACC



LED

10/30V  
9,5 W

✓ R65 ✓ R10



IP6K9K

Exemple de montage D14762 + D14930  
Esempio di montaggio D14762 + D14930  
Ejemplo de montaje D14762 + D14930



110 cm



**D14932**  
(2090L1B110)

Pour Triflash avec 1 gyrophare LED  
Per Triflash con 1 girofaro LED  
Para Triflash con 1 rotativo LED

136 cm



**D14933**  
(2090L1B136)

Pour Triflash avec 1 gyrophare LED  
Per Triflash con 1 girofaro LED  
Para Triflash con 1 rotativo LED

155 cm



**D14934**  
(2090L1B151)

Pour Triflash avec 1 gyrophare LED  
Per Triflash con 1 girofaro LED  
Para Triflash con 1 rotativo LED

110 cm



**D14929**  
(2090L2B110)

Pour Triflash avec 2 gyrophares LED  
Per Triflash con 2 girofari LED  
Para Triflash con 2 rotativos LED

136 cm



**D14930**  
(2090L2B136)

Pour Triflash avec 2 gyrophares LED  
Per Triflash con 2 girofari LED  
Para Triflash con 2 rotativos LED

155 cm



**D14931**  
(2090L2B151)

Pour Triflash avec 2 gyrophares LED  
Per Triflash con 2 girofari LED  
Para Triflash con 2 rotativos LED

181 cm



**D14935**  
(2090L2B181)

Pour Triflash avec 2 gyrophares LED  
Per Triflash con 2 girofari LED  
Para Triflash con 2 rotativos LED



**D14928**  
(2090805000)

Kit de relevage manuel pour -  
Sollevamento manuale incluso  
per - Elevador manual para  
D14760 - D14762 - D14926



**D14922**  
(209080U000)

Support universel - Pattes de  
fixation pour barre Triflash.  
Staffa universale fissaggio per  
barra Triflash.  
Soporte de montaje universal  
para barra Triflash.



**D14989**  
(2090804000)

Kit de fixation sur barre pour  
Triflash électrique D14925.  
Kit montaggio barra per  
Triflash elettrico D14925.  
Kit de montaje sobre barra para  
Triflash eléctrico D14925.

# Feux de pénétration

## Luci direzionali

### Luces direccionales

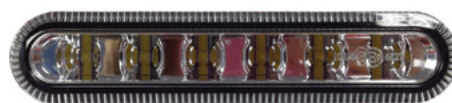
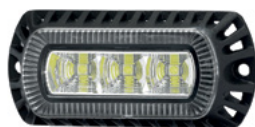

Flashez le QR code pour plus d'infos  
Scansiona il codice QR per maggiori informazioni  
Escanee el código QR para obtener más info



Indice de protection IP - solides/liquides  
Protezione IP - solidi/liquidi  
Protección IP - sólidos/liquidos



Pièces détachées  
Ricambi  
Repuestos



Homologation circulation réseau routier public  
Omologazione circolazione su strada  
Homologación circulación por carretera



Homologation CEM - compatibilité électromagnétique  
Omologazione EMC - compatibilità elettromagnetica  
Homologación CEM - compatibilidad electromagnética



Polycarbonate  
Policarbonato  
Policarbonato



# Feux de pénétration - Luci direzionali - Luces direccionales

## DL SMALL

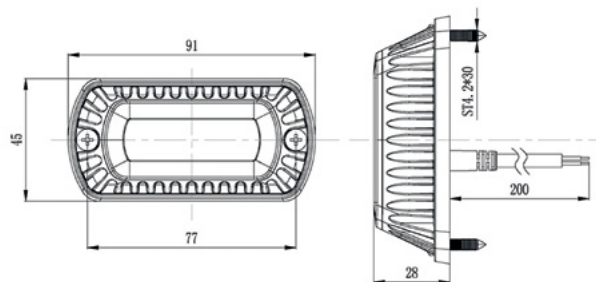

LED

10/30V  
9 W

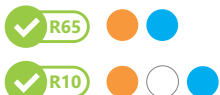

- D13860** ●
- D13863** ○
- D13862** ●

10 types de flash  
10 tipi di flash  
10 tipos de flash

Single (440ms)	Single (1000ms)
Double (480ms)	Triple (930ms)
Quad (725ms)	Penta (850ms)
Double (1000ms)	Triple (750ms)
Quad (610ms)	Penta (800ms)

## DL LONG

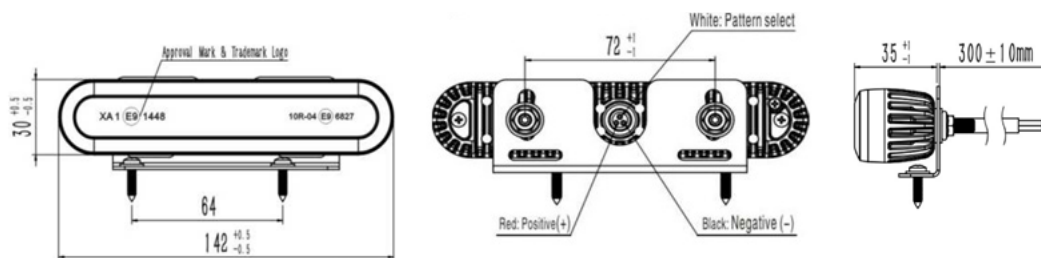

LED

10/30V  
12 W

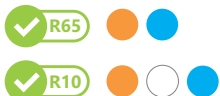

- D14190** ●
- D14354** ○
- D14353** ●

10 types de flash  
10 tipi di flash  
10 tipos de flash

One Flash (600ms)	In turn Double Flash (800ms)
In turn 4 Flash (800ms)	3 Flash (600ms)
5 Flash (1000ms)	1 Flash (960ms)
In turn 3 Flash (600ms)	Unique (410ms)
Frequent Flash (60ms)	Combination



Alternative flash ← →

# Alarmes sonores de recul

## Cicalini retromarcia

### Alarmas sonoras de marcha atrás



Standard



Multi-Frequency



Flashez le QR code pour plus d'infos  
Scansiona il codice QR per maggiori informazioni  
Escanee el código QR para obtener más info



IP69

Indice de protection IP - solides/liquides  
Protezione IP - solidi/liquidi  
Protección IP - sólidos/líquidos



Pièces détachées  
Ricambi  
Repuestos



Homologation CEM - compatibilité électromagnétique  
Omologazione EMC - compatibilità elettromagnetica  
Homologación CEM - compatibilidad electromagnética

## ASR



### STANDARD - ESTÁNDAR

101 mm x 67 mm x 41 mm

Standard



1	<b>630120</b>	87 db
2	<b>630110</b>	82-102 db
3	<b>630100</b>	102 db

1. Chariots élévateurs, petits camions, VUL  
Carelli elevatori, veicoli industriali, veicoli commerciali leggeri  
Carretillas elevadoras, pequeños camiones, vehículos comerciales ligeros
2. Toute utilisation. Ajustement automatique 10 db supérieur au bruit ambiant  
Universale. Regolazione automatica superiore di 10 db al rumore dell'ambiente esterno  
Universal. Ajuste automático a 10 db más arriba que el ruido del entorno exterior
3. Benne à ordure, chantier, forêt, PL  
Veicoli raccolta rifiuti, apparecchiature e veicoli di cantiere, apparecchiature e veicoli forestali, camion  
Dumpers, volquetes, basculas, maquinarias forestales, camiones



12/24V



IP65

### MULTI-FRÉQUENCE - MULTI-FREQUENZA - MULTI-FRECUENCIA

102 mm x 71 mm x 41 mm

Multi-Frequency



<b>D13807</b>	87 db
<b>D13808</b>	97 db

Multi-Frequency



<b>D13810</b>	97 db 1500 mm
---------------	------------------

CLICK-IN



24V

### INTÉGRÉE - INCASSATO - INCORPORADO



<b>001830</b>	90 db
---------------	-------

Pour connection sur feu arrière LC8 p. 150  
Per collegamento su fanale posteriore LC8 p. 150  
Para acoplamiento con piloto trasero LC8 p. 150



<b>001872</b>	55-90db
---------------	---------

Ajustement bruit ambiant sur feu arrière LC8 MAN p. 153  
Regolazione dell'ambiente esterno fanale posteriore LC8 MAN p. 153  
Ajuste al entorno exterior piloto trasero LC8 MAN p. 153



<b>D12953</b>	90 db
---------------	-------

Pour connection sur feu arrière LC9 p. 160, LC7 p. 166  
Per collegamento su fanale posteriore LC9 / LC7 p. 160 / p. 166  
Para acoplamiento con piloto trasero LC9 / LC7 p. 160 / p. 166

# Systemes caméra Telecamere Sistemas de cámara

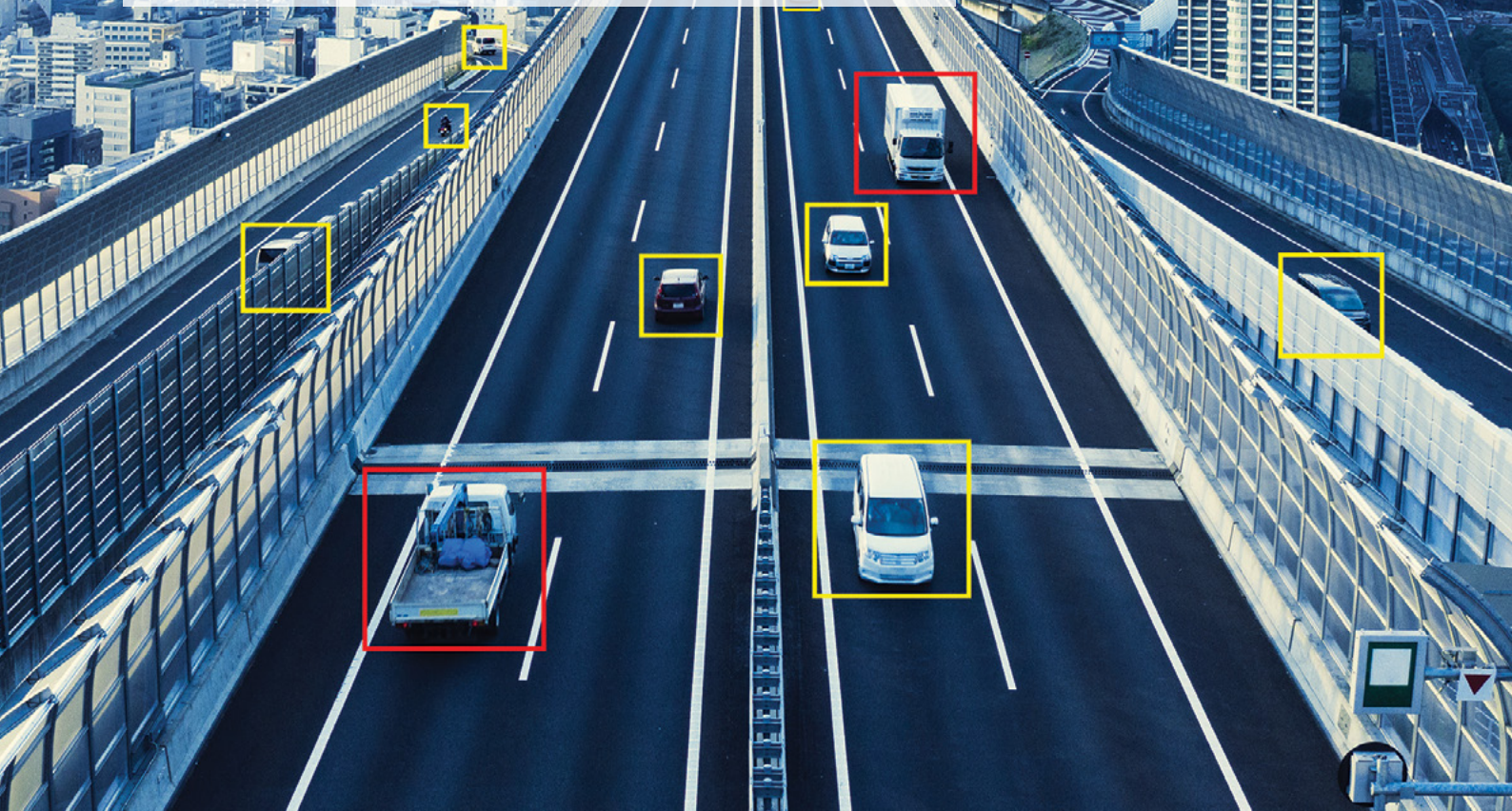

## Systemes sans fil - Sistemi senza filo - Sistemas inalámbricos p. 276-280



## Systemes filaires - Sistemi con filo - Sistemas cableados p. 281-290



Flashez le QR code pour plus d'infos  
Scansiona il codice QR per maggiori informazioni  
Escanee el código QR para obtener más info



Système HD  
Sistema HD  
Sistema HD



Indice de protection IP - solides/liquides  
Protezione IP - solidi/liquidi  
Protección IP - sólidos/liquidos



Écran tactile  
Schermo touch screen  
Pantalla táctil



Pièces détachées  
Ricambi  
Repuestos



Caméra vision nocturne  
Telecamera per visione notturna  
Cámara de visión nocturna



Taille écran  
Grandezza schermo  
Tamaño pantalla



Écran fractionné  
Schermo diviso  
Pantalla dividida



Système sans fil  
Sistema senza filo  
Sistema inalámbrico

## CAM WIRELESS 2.4 GHz



### D14328

12/24V - Ecran fractionné couleur 7 pouces - transmission sans fil 2.4 GHz - Raccordement jusqu'à 4 caméras - **appairage automatique** - Enregistrement en temps réel - Support carte micro SD (non fournie) - Caméra micro intégré - vision de nuit - Utilisation entre -20°C et +70°C

12/24V - Multi schermi a colori 7 pollici - Trasmissione senza fili 2.4 GHz - Collegamento fino a 4 camere - **Associazione automatica** - **Registrazione in tempo reale** - **Supporto scheda micro SD** - Camera con microfono - visione notturna - Usare tra -20°C e +70°C

12/24V - Pantalla color split 7 pulgadas - Transmisión inalámbrica 2.4GHz - Conexión hasta 4 cámaras - **Auto Emparejamiento** - **Grabación en tiempo real** - **Soporte de tarjetas SD** - Cámara con micrófono - visión nocturna - Utilización entre -20°C et +70°C



### TEMPS D'ENREGISTREMENT - TEMPO DI REGISTRAZIONE - TIEMPO DE GRABACIÓN :

MODE \ Micro SD	8G	16G	32G	64G	128G
SINGLE (640x480x1)	14h	28h	55h	110h	220h
QUAD (320x240x4)	11h	22h	43h	86h	172h
SPLIT (400x480x2)	13h	25h	50h	101h	201h

### NOTICE DE BRANCHEMENT - ISTRUZIONI DI CONNESSIONE - INSTRUCCIONES DE CONEXIÓN :



rouge positif - rosso positivo - rojo positivo  
 noir masse - nero massa - negro masa  
 marron recul - marrone retromarcia - marrón marcha atrás  
 blanc clignotant gauche - bianco indicatore a sinistra - blanco intermitente izquierda  
 bleu clignotant droit - blu indicatore a destra - azul intermitente derecha  
 vert ou jaune option - verde o giallo opzione - verde o amarilla opción



Les appareils 2.4 GHz tels que les téléphones cellulaires, les systèmes Bluetooth et Wi-Fi peuvent causer des interférences passagères. I dispositivi 2.4 GHz come cellulari, Bluetooth e Wi-Fi possono creare temporane interferenze. Los dispositivos 2.4 GHz como teléfonos celulares, sistemas Bluetooth y inalámbricos pueden causar interferencias temporales.



COMPOSEZ VOTRE KIT SUR-MESURE  
 CREA IL TUO KIT PERSONALIZZATO  
 DISEÑA SU PROPIO KIT PERSONALIZADO

### 1. ECRAN - SCHERMO - PANTALLA



**D14216**

Ecran 7" - Schermo 7" - Pantalla 7"  
 Fractionnable - Multi schermo - Dividida

### 2. CAMÉRA - CAMERA - CÁMARA



**D14236**

**NEW**



**D14906**

**NEW**



**D14882**

batterie rechargeable  
 batteria ricaricabile  
 batería recargable

### 3. ACCESSOIRES - ACCESSORI - ACCESORIOS



**D14063**

7 m



**D14326**

antenne écran - antenna schermo - antena de pantalla



**D14195**

antenne caméra - antenna camera - antena de cámara



**D14347**

10/32V

Batterie mobile 10-12h autonomie  
 Batteria mobile 10-12h autonomia  
 Batería móvil 10-12h autonomía



Exemple de montage - Esempio di montaggio - Ejemplo de montaje  
 Kit D14328 + D14236 x 3

## CAM WIRELESS HD 2.4 GHz



**NEW**

### D14805

12/24V - Image HD 720P - Ecran fractionné couleur 7 pouces - transmission sans fil 2.4 GHz - Raccordement jusqu'à 4 caméras - **appairage automatique** - Enregistrement en temps réel - Support carte micro SD (non fournie) - Caméra micro intégré - vision de nuit - Utilisation entre -20°C et +70°C

12/24V - Immagine HD 720P - Multi schermi a colori 7 pollici - Trasmissione senza fili 2.4 GHz - Collegamento fino a 4 camere - **Associazione automatica** - Registrazione in tempo reale - Supporto scheda micro SD - Camera con microfono - visione notturna - Usare tra -20°C e +70°C

12/24V - Imagen HD 720P - Pantalla color split 7 pulgadas - Transmisión inalámbrica 2.4GHz - Conexión hasta 4 cámaras - **Auto Emparejamiento** - Grabación en tiempo real - Soporte de tarjetas SD - Cámara con micrófono - visión nocturna - Utilización entre -20°C et +70°C



### TEMPS D'ENREGISTREMENT - TEMPO DI REGISTRAZIONE - TIEMPO DE GRABACIÓN :

MODE \ Micro SD	8G	16G	32G	64G	128G
SINGLE (640x480x1)	14h	28h	55h	110h	220h
QUAD (320x240x4)	11h	22h	43h	86h	172h
SPLIT (400x480x2)	13h	25h	50h	101h	201h

### NOTICE DE BRANCHEMENT - ISTRUZIONI DI CONNESSIONE - INSTRUCCIONES DE CONEXIÓN :



rouge positif - rosso positivo - rojo positivo  
 noir masse - nero massa - negro masa  
 marron recul - marrone retromarcia - marrón marcha atrás  
 blanc clignotant gauche - bianco indicatore a sinistra - blanco intermitente izquierda  
 bleu clignotant droit - blu indicatore a destra - azul intermitente derecha  
 vert ou jaune option - verde o giallo opzione - verde o amarilla opción



Les appareils 2.4 GHz tels que les téléphones cellulaires, les systèmes Bluetooth et Wi-Fi peuvent causer des interférences passagères. I dispositivi 2.4 GHz come cellulari, Bluetooth e Wi-Fi possono creare temporane interferenze. Los dispositivos 2.4 GHz como teléfonos celulares, sistemas Bluetooth y inalámbricos pueden causar interferencias temporales

## ACC WIRELESS HD 720P



COMPOSEZ VOTRE KIT SUR-MESURE  
 CREA IL TUO KIT PERSONALIZZATO  
 DISEÑA SU PROPIO KIT PERSONALIZADO

### 1. ECRAN - SCHERMO - PANTALLA

**NEW**



**D14803**

Ecran 7" - Schermo 7" - Pantalla 7"  
 Fractionnable - Multi schermo - Dividida

### 2. CAMÉRA - CAMERA - CÁMARA

**NEW**

∠110°



**D14804**

**NEW**

∠110°



**D14905**

capot motorisé - otturatore automatico - obturador automático



### 3. ACCESSOIRES - ACCESSORI - ACCESORIOS



**D14326**

antenne écran - antenna schermo - antena de pantalla



**D14195**

antenne caméra - antenna camera - antena de cámara



**D14347** 10/32V

Batterie mobile 10-12h autonomie  
 Batteria mobile 10-12h autonomia  
 Batería móvil 10-12h autonomía



## CAM WIFI



∠110°

**NEW**



**D14806**



Magnétique et sur batterie rechargeable, l'installation est rapide et simple. Après avoir téléchargé l'application sur votre **smartphone** ou tablette (voir notice), vous pouvez regarder en temps réel la vidéo par wifi mais aussi faire des captures d'écran. Câble de rechargement USB fourni.



Batteria magnetica e ricaricabile, l'installazione è semplice e veloce. Dopo aver scaricato l'applicazione sul tuo **smartphone** o tablet (vedi istruzioni), puoi guardare il video in tempo reale tramite Wi-Fi ma anche acquisire schermate. Cavo USB ricaricabile incluso.

Batería magnética y recargable, la instalación es rápida y sencilla. Después de descargar la aplicación en su **smartphone** o tableta (consulte las instrucciones), puede ver el video en tiempo real a través de wifi pero también tomar capturas de pantalla. Cable de carga USB incluido.



RECOMMANDÉ IOS + ANDROID  
IOS + ANDROID CONSIGLIATI  
RECOMENDADO PARA IOS + ANDROID



## CAM WIRED



ENVIRONNEMENT SEVERE  
AMBIENTE ESTREMO  
AMBIENTE EXTREMO

∠120°



20 m

**NEW**

### D14091

12/24V - Ecran couleur 7 pouces - Raccordement possible pour 1 caméra - Caméra LED en aluminium/inox micro intégré - vision de nuit - Utilisation entre -40°C et +70°C

12/24V - Schermo a colori 7 pollici - Possibilità di collegamento a 1 camera- camera in alluminio/acciaio con microfono - visione notturna - Usare tra -40°C e +70°C

12/24V - Pantalla color 7 pulgadas - Conexión posible para 1 cámara - Cámara de aluminio con micrófono - visión nocturna - Utilización entre -40°C y +70°C



## CAM WIRED

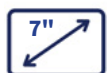

∠ 120°



20 m

**NEW**

### D14915

12/24V - Ecran couleur 7 pouces - Raccordement possible pour 1 caméra - Caméra LED CMOS micro intégré - vision de nuit - Utilisation entre -40°C et +70°C

12/24V - Schermo a colori 7 pollici - Possibilità di collegamento a 1 camera- camera CMOS con microfono - visione notturna - Usare tra -40°C e +70°C

12/24V - Pantalla color 7 pulgadas - Conexión posible para 1 cámara - Cámara CMOS con micrófono - visión nocturna - Utilización entre -40°C y +70°C



## CAM WIRED

NOTICE DE BRANCHEMENT D14091 - D14915 - ISTRUZIONI DI CONNESSIONE - INSTRUCCIONES DE CONEXIÓN :



rouge positif - rosso positivo - rojo positivo  
 noir masse - nero massa - negro masa  
 Fil marron recul - filo marrone retromarcia - cable marrón marcha atrás  
 Connecteur marron camera - connettore marrone camera - conector marrón cámara

## ACC WIRED



COMPOSEZ VOTRE KIT SUR-MESURE  
 CREA IL TUO KIT PERSONALIZZATO  
 DISEÑA SU PROPIO KIT PERSONALIZADO



12/24V

### 1. ECRAN - SCHERMO - PANTALLA

**NEW**



**D14916**

Ecran 7" - Schermo 7" - Pantalla 7"  
 Pour 1 caméra - Per 1 camera - Para 1 cámara



### 2. CAMÉRA - CAMERA - CÁMARA



12/24V

∠120°



**D13617**

∠120°



**D13881**

Aluminium/Inox - Alluminio / acciaio - Aluminio Acero Inoxidable

∠150°



**D14148**

Slim grand angle  
 Compatta grandangolare  
 Compacta gran angular

∠120°



**D14327**

Motorisée + chauffante  
 Motorizzato + riscaldato  
 Motorizado + calefacción

## ACC WIRED



### 2. CAMÉRA - CAMERA - CÁMARA

∠150°

**NEW**



**D14808**

Top view grand angle  
Montaggio alto grandangolare  
Montaje alto gran angular



∠150°

**NEW**



**D14807**

Top view grand angle  
Montaggio alto grandangolare  
Montaje alto gran angular



### 3. CÂBLAGE - CABLAGGIO - CABLEADO



**D13620**



**D13621**

10 m

**D13622**

20 m



### EXEMPLES DE MONTAGE - ESEMPIO DI MONTAGGIO - EJEMPLOS DE MONTAJE



## CAM WIRED HD 720P



ENVIRONNEMENT SEVERE  
AMBIENTE ESTREMO  
AMBIENTE EXTREMO



∠110°



20 m

**NEW**

### D14904



12/24V - Qualité d'image HD 720P - Ecran couleur 7 pouces - Raccordement jusqu'à 3 caméras - Caméra LED en inox micro intégré - vision de nuit - Utilisation entre -20°C et +70°C

12/24V - Qualità dell'immagine HD 720P - Schermo a colori 7 pollici - Collegamento fino a 3 camere - Camera in acciaio con microfono - visione notturna - Usare tra -20°C e +70°C

12/24V - Calidad de imagen HD 720P - Pantalla color 7 pulgadas - Conexión hasta 3 cámaras - Cámara de acero inoxidable con micrófono - visión nocturna - Utilización entre -20°C y +70°C

## CAM WIRED HD 720P



∠110°



20 m

**NEW**

### D14903



12/24V - Qualité d'image HD 720P - Ecran couleur 7 pouces - Raccordement jusqu'à 3 caméras - Caméra LED en aluminium micro intégré - vision de nuit - Utilisation entre -20°C et +70°C

12/24V - Qualità dell'immagine HD 720P - Schermo a colori 7 pollici - Collegamento fino a 3 camere - Camera in alluminio con microfono - visione notturna - Usare tra -20°C e +70°C

12/24V - Calidad de imagen HD 720P - Pantalla color 7 pulgadas - Conexión hasta 3 cámaras - Cámara de aluminio con micrófono - visión nocturna - Utilización entre -20°C y +70°C

## CAM WIRED HD 720P

NOTICE DE BRANCHEMENT D14904 - D14903 - ISTRUZIONI DI CONNESSIONE - INSTRUCCIONES DE CONEXIÓN :



## ACC WIRED HD 720P



COMPOSEZ VOTRE KIT SUR-MESURE  
 CREA IL TUO KIT PERSONALIZZATO  
 DISEÑA SU PROPIO KIT PERSONALIZADO



### 1. ECRAN - SCHERMO - PANTALLA

**NEW**



**D14901**

Ecran 7" - Schermo 7" - Pantalla 7"  
 Pour 3 caméras - Per 3 camere - Para 3 cámaras

### 2. CAMÉRA - CAMERA - CÁMARA

∠110°



**D14900**

Aluminium - Alluminio - Alu-  
 minio

∠110°



**D14902**

Inox - Acciaio - Acero Inoxidable

### 3. CÂBLAGE - CABLAGGIO - CABLEADO



**D13620**

Pour 1 caméra HD720P - Per  
 1 camera HD720P - Para 1  
 cámara HD 720P



**D14685**

Pour 2 caméras HD - Per 2 ca-  
 mere HD - Para 2 cámaras HD



**D13621**

10 m

**D13622**

20 m

## CAM WIRED HD 1080P



### D14677

12/24V - Qualité d'image HD 1080P - Ecran couleur 7 pouces tactile - Raccordement jusqu'à 3 caméras - Design épuré

12/24V - Qualità dell'immagine HD 1080P - Schermo "touch screen" a colori 7 pollici - Collegamento fino a 3 camere - Disegno lineare

12/24V - Calidad de imagen HD 1080P - Pantalla táctil color 7 pulgadas - Conexión hasta 3 cámaras - Diseño limpio



## CAM WIRED HD 1080P



### D14680

12/24V - Qualité d'image HD 1080P - Ecran couleur 10 pouces tactile - Raccordement jusqu'à 3 caméras - Design épuré

12/24V - Qualità dell'immagine HD 1080P - Schermo "touch screen" a colori 10 pollici - Collegamento fino a 3 camere - Disegno lineare

12/24V - Calidad de imagen HD 1080P - Pantalla táctil color 10 pulgadas - Conexión hasta 3 cámaras - Diseño limpio



## CAM WIRED HD 720P

**NOTICE DE BRANCHEMENT D14677 - D14680 - ISTRUZIONI DI CONNESSIONE - INSTRUCCIONES DE CONEXIÓN :**



Exemple de montage - Esempio di montaggio - Ejemplo de montaje  
Kit D14677 + D13621 + D13685



## ACC WIRED HD 1080P



COMPOSEZ VOTRE KIT SUR-MESURE  
CREA IL TUO KIT PERSONALIZZATO  
DISEÑA SU PROPIO KIT PERSONALIZADO

### 1. ECRAN - SCHERMO - PANTALLA



**D14678**

Ecran mono HD 7" - Schermo mono HD 7" - Pantalla mono HD 7"



**D14681**

Ecran mono HD 10" - Schermo mono HD 10" - Pantalla mono HD 10"



**D14683**

Ecran quad HD 7" fractionnable - Multi schermo quad HD 7" - Pantalla quad HD 7" de vista multiples



**D14684**

Ecran quad HD 10" fractionnable - Multi schermo quad HD 10" - Pantalla quad HD 10" de vista multiples

### NOTICE DE BRANCHEMENT D14683 - D14684 - ISTRUZIONI DI CONNESSIONE - INSTRUCCIONES DE CONEXIÓN :

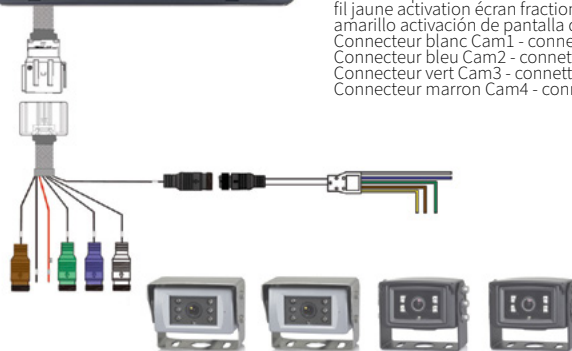

rouge positif - rosso positivo - rojo positivo  
noir masse - nero massa - negro masa  
fil blanc positif Cam1 - filo bianco positivo Cam1 - cable blanco positivo Cam1  
fil bleu positif Cam2 - filo blu positivo Cam2 - cable azul positivo Cam2  
fil vert positif Cam3 - filo verde positivo Cam3 - cable verde positivo Cam3  
fil marron positif Cam4 - filo marrone positivo Cam4 - cable marrón positivo Cam4  
fil jaune activation écran fractionné - filo gallo attivazione dello schermo diviso - cable amarillo activación de pantalla dividida  
Connecteur blanc Cam1 - connettore bianco Cam1 - conector blanco Cam1  
Connecteur bleu Cam2 - connettore blu Cam2 - conector azul Cam2  
Connecteur vert Cam3 - connettore verde Cam3 - conector verde Cam3  
Connecteur marron Cam4 - connettore marrone Cam4 - conector marrón Cam4

### 2. CAMÉRA - CAMERA - CÁMARA

∠130°



**D14679**

Aluminium - Alluminio - Aluminio HD 1080P

∠130°



**D14682**

Inox - Acciaio - Acero Inoxidable HD 1080P

### 3. CÂBLAGE - CABLAGGIO - CABLEADO



**D14685**

Pour 2 caméras HD720P - Per 2 camere HD720P - Para 2 cámaras HD 720P



**D13621**

10 m

**D13622**

20 m



Exemple de montage - Esempio di montaggio - Ejemplo de montaje

## CAM 360° HD 1080P



∠190°



**NEW**

### D14859

12/24V - Qualité d'image HD 1080P - 1 boîtier de contrôle + 4 caméras HD 1080P extra grand angle 190°. Écran non inclus.

12/24V - Qualità dell'immagine HD 1080P - 1 Scatolla di controllo + 4 telecamere HD 1080P extra grandangolari da 190°. Schermo non incluso.

12/24V - Calidad de imagen HD 1080P - 1 caja de control + 4 cámaras HD 1080P extra gran angular 190°. Pantalla no incluida.



### D14678

Ecran mono HD 7" - Schermo mono HD 7" - Pantalla mono HD 7"



### D14681

Ecran mono HD 10" - Schermo mono HD 10" - Pantalla mono HD 10"



### D14683

Ecran quad HD 7" fractionnable - Multi schermo quad HD 7" - Pantalla quad HD 7" de vista múltiples



### D14684

Ecran quad HD 10" fractionnable - Multi schermo quad HD 10" - Pantalla quad HD 10" de vista múltiples

**NEW**



### D14901

Ecran 7" - Schermo 7" - Pantalla 7"  
Pour 3 caméras - Per 3 camere - Para 3 cámaras



## CAM WIRED DETECTION



**NEW**  $\angle 140^\circ$

ALERTE AUDIO  
AVVISO AUDIO  
ALERTA AUDIO



12/24V



IP69K



### D14995

12/24V - Qualité d'image HD 1080P - Détection de piétons et cyclistes 0,5 - 12 m

12/24V - Qualità dell'immagine HD 1080P - Rilevamento di pedoni e ciclisti 0,5 - 12 m

12/24V - Calidad de imagen HD 1080P - Detección de peatones y ciclistas 0,5 - 12 m



### D14678

Ecran mono HD 7" - Schermo mono HD 7" - Pantalla mono HD 7"



### D14681

Ecran mono HD 10" - Schermo mono HD 10" - Pantalla mono HD 10"



### D13621

10 m

### D13622

20 m

## CAM WIRED MIRRORS



**NEW**

**NEW**



12/24V



IP69K



### D14955

Ecran miroir HD 12,3" - Schermo a specchio HD 12,3" - Pantalla de espejo HD 12,3"



### D14956

# Coffres porte extincteur

## Cassonetti porta estintore

### Porta extintores



Flashez le QR code pour plus d'infos  
Scansiona il codice QR per maggiori informazioni  
Escanee el código QR para obtener más info

## 5054

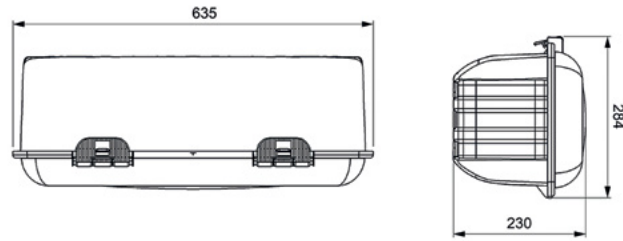

Max 6 kg

**D14538**  
(50.52.925.TV2)

Avec sangle nylon - Con cinghie nylon - Con correa de nylon



Max 6 kg

**D14539**  
(50.52.925.TVC)

Avec sangle CLIP réglable - Con cinghie di fissaggio regolabili CLIP - Con correa ajustable CLIP

## 5051

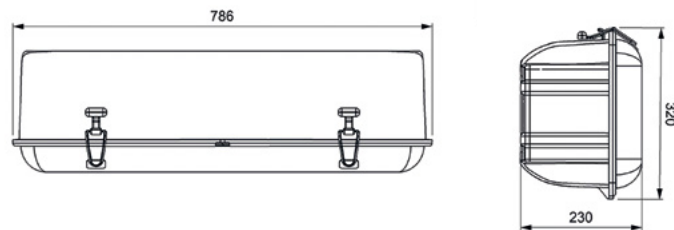

Max 9 kg

**D14537**  
(50.51.020.VLG)

Avec sangle plastique - Con cinghie di plastica - Con correa de plástico

# Prises et câbles spiralés

## Spine e spirali

### Enchufes y espirales



**NEW**



**NEW**



Flashez le QR code pour plus d'infos  
Scansiona il codice QR per maggiori informazioni  
Escanee el código QR para obtener más info

# Prises et câbles spiralés - Spine e spirali - Enchufes y espirales

## 7P



24V

24N (ISO 1185)  
24S (ISO 3731)

### MÉTALLIQUE - METALLICA - METÁLICA



**D10873**

24N



**611530**

24N



**D10874**

24S



**611550**

24S

### PLASTIQUE - PLASTICA - PLÁSTICA



**611500**

24N



**611580**

24N



**611510**

24S



**611590**

24S



**611520**

24N



**611540**

24S

## C7P



Longueur de travail : L  
 Lunghezza di funzionamento : L  
 Longitud de funcionamiento : L

LMax  
 Longueur d'extension maximale  
 :Massima lunghezza d'estensione  
 Longitud máxima de extensión

### MÉTALLIQUE - METALLICA - METÁLICA



24N

**D14313** LMax 3,5 m

**611140** L : 3 m, LMax 4,5 m



24S

**D14314** LMax 3,5 m

**611150** L : 3 m, LMax 4,5 m

### PLASTIQUE - PLASTICA - PLÁSTICA



24N

**D14312** LMax 3,5 m

**611070** L : 3 m, LMax 4,5 m



24S

**D14316** LMax 3,5 m

**611080** L : 3 m, LMax 4,5 m

EURO6

**D14574** L : 3 m, LMax 4,5 m

**D14575** L : 3 m, LMax 4,5 m

EURO6

6 x 1,0 mm<sup>2</sup> + 1 x 1,5 mm<sup>2</sup>



**611110** 24N/24S

24N

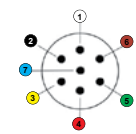

- ① - Masse
- ② - Feu de position G
- ③ - Clignotant G
- ④ - Feu Stop
- ⑤ - Clignotant D
- ⑥ - Feu de position D,
- ⑦ - Commande de frein

- Common return
- L rear position lamp
- L flasher lamp
- Stop lamp
- R flasher lamp
- R rear position lamp,
- Breaking control

- Masse
- Linke Schlussleuchte
- Fahrlichtungsanzeiger links
- Bremsleuchte
- Fahrlichtungsanzeiger rechts
- Rechte Schlussleuchte
- Steuerung Anhängerbremse

24S

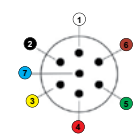

- ① - Masse
- ② - Sans affectation
- ③ - Feu de recul
- ④ - Alimentation en puissance
- ⑤ - Sans affectation
- ⑥ - Sans affectation
- ⑦ - Feu AR de brouillard

- Common return
- Without affectation
- Reverse lamp
- Power supply
- Without affectation
- Without affectation
- Fog lamp

- Masse
- Nicht belegt
- Rückfahrleuchte
- Stromversorgung (Dauerplus)
- Nicht belegt
- Nicht belegt
- Nebelschlussleuchte



# Prises et câbles spiralés - Spine e spirali - Enchufes y espirales

## 15P



24V

ISO 12098



**A10060**



**A10061**



**D14315** LMax 3,5 m

**D11578** L : 3 m, LMax 4,5 m

**D14577** L : 3 m, LMax 4,5 m **EURO6**

## 7P-15P



24V



**D11487** L : 3 m, LMax 4,5 m

**NEW D14824** LMax 3,5 m



**D14689** L : 3 m, LMax 4,5 m

**EURO6 D14578** L : 3 m, LMax 4,5 m

**NEW D14802** LMax 3,5 m



**611410**



**D13889**



**A10064**

## ABS/EBS



ISO 7638-1



**611560** ABS/EBS



**A10062** ABS/EBS



**A10065** ABS/EBS

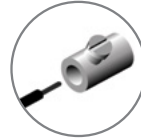

**A10066** ABS/EBS



**D14311** LMax 3,5 m ABS/EBS 7P

**D10597** L : 3 m, LMax 4,5 m ABS/EBS 7P

**D14576** L : 3 m, LMax 4,5 m ABS/EBS 7P **EURO6**



**611570** PARC ABS/EBS-15P

### ABS/EBS



- |   |                    |                    |
|---|--------------------|--------------------|
| ① - Plus (+) alimentation électrovanne  | Plus electrovalve  | Plus Magnetventil  |
| ② - Plus (+) connexions électroniques   | Plus electronics   | Plus Elektronik    |
| ③ - Moins (-) connexions électroniques  | Minus electronics  | Minus Elektronik   |
| ④ - Moins (-) alimentation électrovanne | Minus electrovalve | Minus Magnetventil |
| ⑤ - Connexion lampe témoin              | Warning device     | Warneinrichtung    |
| ⑥ - Connexion donnée CANH               | CANH               | Datenleitung CANH  |
| ⑦ - Connexion donnée CANL               | CANL               | Datenleitung CANL  |

### 15 PÔLES



- |                                      |                            |   |
|--------------------------------------|----------------------------|---|
| ① - Clignotant gauche                | L flasher lamp             | Fahrtrichtungsanzeiger links            |
| ② - Clignotant droit                 | R flasher lamp             | Fahrtrichtungsanzeiger rechts           |
| ③ - Feu AR de brouillard             | Fog lamp                   | Nebelschlussleuchte                     |
| ④ - Masse                            | Common return              | Masse                                   |
| ⑤ - Feu de position gauche           | L rear position lamp       | Linke Schlussleuchte                    |
| ⑥ - Feu de position droit            | R rear position lamp       | Rechte Schlussleuchte                   |
| ⑦ - Feu stop                         | Stop lamp                  | Bremsleuchte                            |
| ⑧ - Feu de recul                     | Reverse lamp               | Rückfahrleuchte                         |
| ⑨ - Alimentation 24V                 | 24V power supply           | Stromversorgung +24V                    |
| ⑩ - Capteur d'usure des freins       | Worn brake indicator       | Sensor für Bremsbelagverschleissanzeige |
| ⑪ - Capteurs de pressions des freins | Brake pressure collector   | Anzeige für Federspeicherbremse         |
| ⑫ - Dispositif de levage d'essieu    | Adjustable suspension lift | Achsanhebung                            |
| ⑬ - Masse pour contacts 14 et 15     | Common return              | Masse für Datenleitungen                |
| ⑭ - Bus de données                   | Data line                  | Datenleitung                            |
| ⑮ - Bus de données                   | Data line                  | Datenleitung                            |

## 9P ISOBUS IBBC



12V

ISO 11783-2

**NEW**



**D14942**



**D14943**

4P-IBBC



**D14944**

TBC



**D14945** 6 mm<sup>2</sup>

**D14947** 10 mm<sup>2</sup>

**D14948** 16 mm<sup>2</sup>



**D14949** 6 mm<sup>2</sup> - cable 5 m

**D14950** 10 mm<sup>2</sup> - cable 5 m

**D14951** 10 mm<sup>2</sup> - cable 10 m



# Connecteurs Connettori Conectores



Flashez le QR code pour plus d'infos  
Scansiona il codice QR per maggiori informazioni  
Escanee el código QR para obtener más info

AMP 1.5-7P-M

Type connecteur - Nb pins - Mâle ou Femelle  
Tipo di connettore - Num pin - Maschio o Femmina  
Tipo de conector - Num pines - macho o hembra

# Connecteurs - Connettori - Conectores

## AMP 1.5



**D11868** AMP 1.5-7P-F

Connecteur AMP 1.5 simple  
Connettore AMP 1.5 singolo  
Conector AMP 1.5 simple

Pour / Per / Para  
LC5, LC7, LC8, LC9, LC12, LC11, LC10



## HDSCS

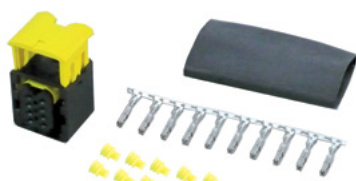

**D13878** HDSCS-8P-F

Connecteur HDSCS simple  
Connettore HDSCS singolo  
Conector HDSCS simple

Pour / Per / Para  
LC8



## JPT



**D13876** JPT-2P-F

Connecteur JPT 2 voies  
Connettore JPT 2 vie  
Conector JPT 2 vías

Pour / Per / Para  
EPP98, SMD98,  
FPL93, FE98



**D13877** JPT-3P-F

Connecteur JPT 3 voies  
Connettore JPT 3 vie  
Conector JPT 3 vías

Pour / Per / Para  
ICDL94



## POS



**D13879** POS-2P-F

Connecteur 2 voies position femelle  
Connettore 2 vie femmina  
Conector 2 vías hembra

Pour / Per / Para  
LC8T, DX



**D14214** POS-2P-M

Connecteur 2 voies position mâle  
Connettore 2 vie maschio  
Conector 2 vías macho

## SUPERSEAL



**D13880**

SS-2P-F

Connecteur SUPERSEAL 2 voies femelle  
Connettore SUPERSEAL 2 vie femmina  
Conector SUPERSEAL 2 vías hembra

Pour / Per / Para  
SMD98, FPL93, LC12, IC DL10,  
LPL18



**D14208**

SS-2P-M

Connecteur SUPERSEAL 2 voies mâle  
Connettore SUPERSEAL 2 vie maschio  
Conector SUPERSEAL 2 vías macho



**D14362**

SS-3P-F

Connecteur SUPERSEAL 3 voies femelle  
Connettore SUPERSEAL 3 vie femmina  
Conector SUPERSEAL 3 vías hembra

Pour / Per / Para  
SMCU

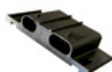

**D14331**

SS-3P-M

Connecteur SUPERSEAL 3 voies mâle  
Connettore SUPERSEAL 3 vie maschio  
Conector SUPERSEAL 3 vías macho

## DT



**D14170**

DT-2P-F

connecteur 2 voies DT  
connettore 2 vie DT  
conector 2 vías DT

Pour / Per / Para  
Feux de travail, Fari di lavoro,  
Faros de trabajo

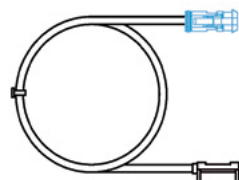

**R12486**

1500 mm

câble adaptateur DT 2V-CLICK-IN  
cavo adattatore DT 2V-CLICK-IN  
cable adaptador DT 2V-CLICK-IN

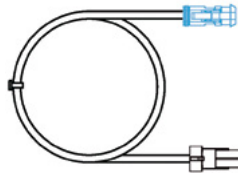

**R14413**

1500 mm

câble adaptateur DT-SUPERSEAL  
cavo adattatore DT-SUPERSEAL  
cable adaptador DT-SUPERSEAL



**D14436** DT06-4S-4P-F

connecteur 4 voies DT06-4S femelle  
connettore 4 vie DT06-4S femmina  
conector 4 vías DT06-4S hembra



Pour / Per / Para  
CTL15, BL15



**D14434** DT04-4P-M

connecteur 4 voies DT04-4P mâle  
connettore 4 vie DT04-4P maschio  
conector 4 vías DT04-4P macho



**D14437** DTM06-4S-4P-F

connecteur 4 voies DTM06-4S femelle  
connettore 4 vie DTM06-4S femmina  
conector 4 vías DTM06-4S hembra

Pour / Per / Para  
CTL15, BL15



**D14435** DTM04-4P-M

connecteur 4 voies DTM04-4P mâle  
connettore 4 vie DTM04-4P maschio  
conector 4 vías DTM04-4P macho



**D14352** DT-6P-M

connecteur 6 voies DT  
connettore 6 vie DT  
conector 6 vías DT

Pour / Per / Para  
CHL



# Faisceaux Cablaggi Cableados

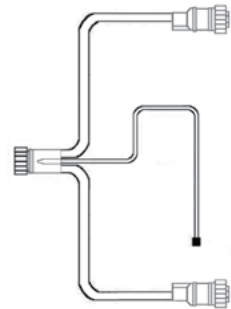
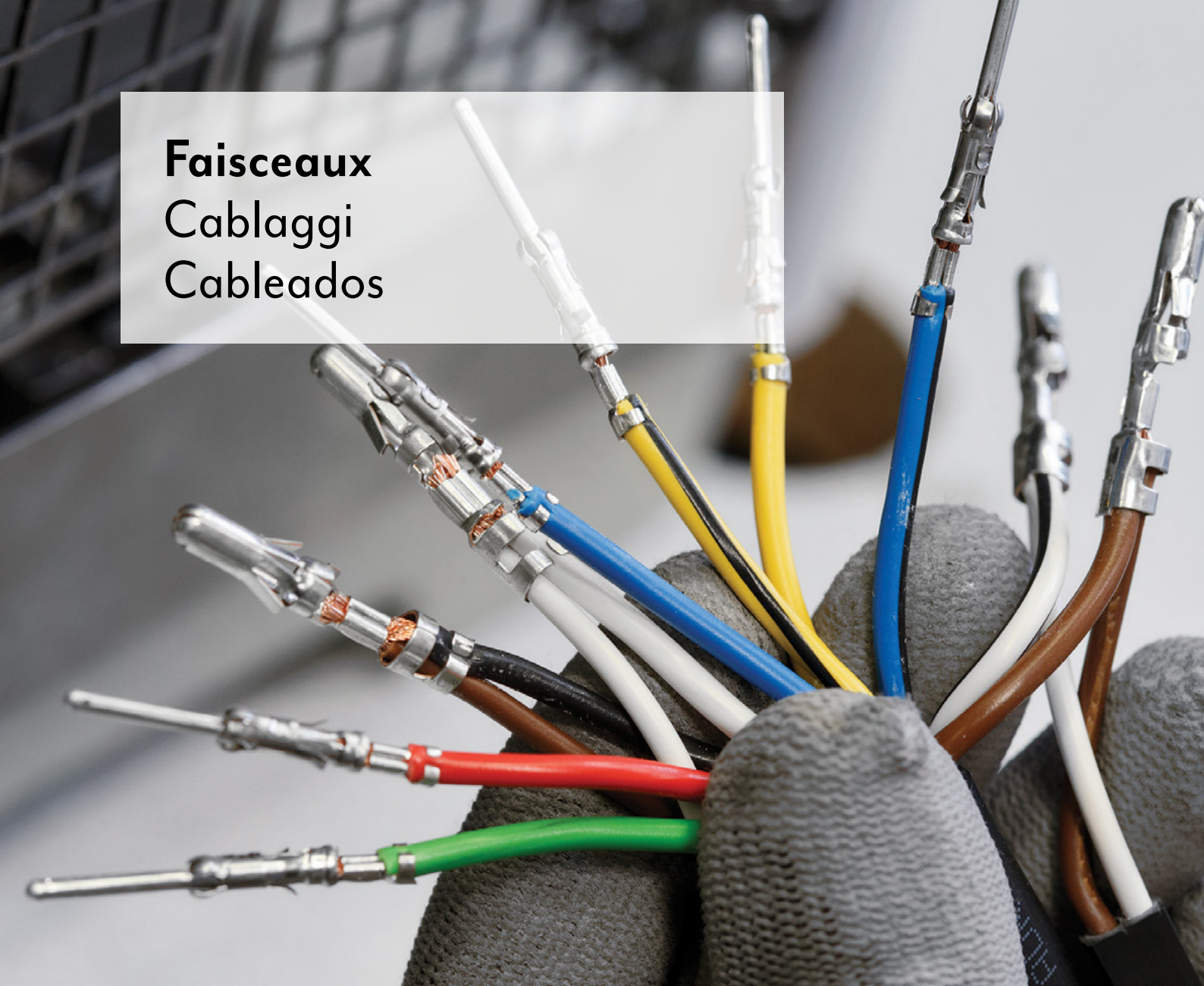

Flashez le QR code pour plus d'infos  
Scansiona il codice QR per maggiori informazioni  
Escanee el código QR para obtener más info

AMP 1.5-7P-M

Type connecteur - Nb pins - Mâle ou Femelle  
Tipo di connettore - Num pin - Maschio o Femmina  
Tipo de conector - Num pines - macho o hembra



## ADP RSC



ADR



24N 24S / 15P

### ADAPTATEURS AVANT - PRESE ANTERIORE - ENCHUFES DELANTEROS

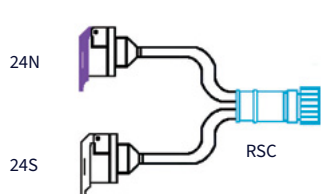

**D10504** 1000 mm 16V

**D13257** 1500 mm 15V

Faisceau prises 24N / 24S  
Cavo con connettore 24N / 24S  
Cable con enchufes 24N / 24S

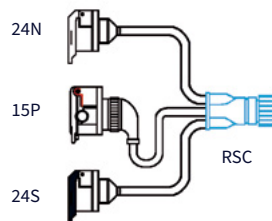

**D14780** 500 mm 16V

**D13256** 300 mm 15V

Faisceau prises 15P / 24N / 24S  
Cavo con connettore 15P / 24N / 24S  
Cable con enchufes 15P / 24N / 24S



**D13254** 1000 mm 16V

**D13255** 600 mm 15V

Faisceau prises 15P  
Cavo con connettore 15P  
Cable con enchufes 15P

#### Comment différencier rapidement les connecteurs RSC ? Come distinguere i connettori RSC? ¿Cómo distinguir los conectores RSC?

Un connecteur RSC 16 voies présente 4 pins centraux alors qu'un connecteur RSC 15 voies en présente 3 (voir schéma ci-contre).

Un connettore RSC 16 vie presente 4 pins nel centro, mentre un connettore RSC 15 vie ne presente solo 3 (vedere disegno allegato).

Un conector RSC 16 polos tiene 4 pins en el centro mientras que un conector RSC 15 polos tiene 3 pins (esquema).

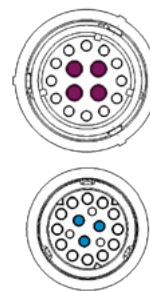

## PRL RSC



ADR

### CÂBLE D'ALIMENTATION PRINCIPALE - CAVO DI ALIMENTAZIONE PRINCIPALE - MANGUERA DE ALIMENTACIÓN PRINCIPAL



**D10505** 16 m 16V

**D13263** 15 m 15V

Prolongateur RSC simple  
Prolunga RSC semplice  
Manguera alargadora RSC simple

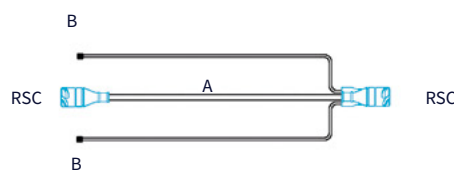

**D10510** A: 10 m / B: 10 m 16V

**D10508** A: 16 m / B: 16 m 16V

**D13260** A: 15 m / B: 0,27 m\* 15V

Prolongateur avec câbles plats  
Prolunga RSC con cavi piatti  
Manguera alargadora RSC con cables planos  
\* avec autoproforants / con click-in



**D13249** 16V

Connecteur RSC femelle presse étoupe + contacts  
Femmina RSC connettore pressacavo + contacts  
Hembra RSC conector con prensa estopa + contactos



**D13250** 16V

Connecteur RSC mâle presse étoupe + contacts  
Maschio RSC connettore pressacavo + contacts  
Macho RSC conector con prensa estopa + contactos



ADR

Exemple de montage p. 272  
Esempio di montaggio p. 272  
Ejemplo de montaje p. 272

### ADAPTATEURS ARRIÈRE - PRESE OSTERIORE - ENCHUFES TRASEROS

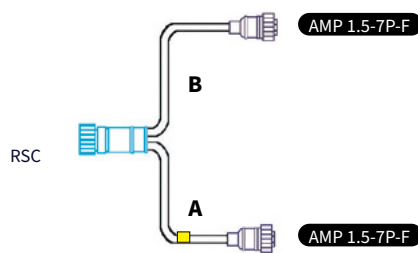

**D10513** A: 3,5 m / B: 3,5 m 16V

Faisceau pour feux arrière avec surmoulages droits  
Cavo per fanali posteriori con connettore pressofuso dritto  
Manguera para pilotos traseros con conector sobremoldeado rectos  
■ = gauche - sinistra - derecha

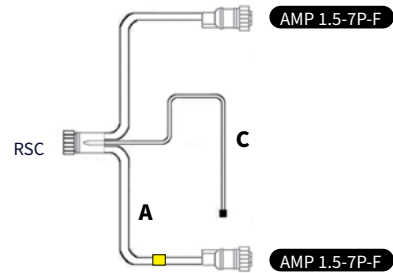

**D13262** A: 2,5 m / B: 1,5 m / C: 1,2 m 15V

Faisceau pour feux arrière avec câbles plats et surmoulages droits  
Cavo per fanali posteriori con cavi piatti e connettori pressofuso dritto  
Manguera para pilotos traseros con cables planos y conectores sobremoldeado rectos  
■ = gauche - sinistra - derecha

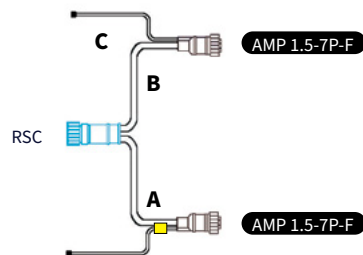

**D10514** A/B: 2 m / C: 0,5 m 16V

**D10515** A: 1,5 m / B: 2,5 m / C: 16 m 16V

**R12499** A: 2,5 m / B: 1,5 m / C: 0,5 m 15V

Faisceau pour feux arrière avec câbles plats et surmoulages droits  
Cavo per fanali posteriori con connettore pressofuso dritto  
Manguera para pilotos traseros con conector sobremoldeado rectos

■ = gauche - sinistra - derecha

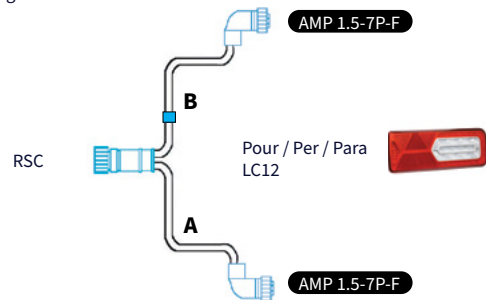

**R14407** A: 2 m / B: 2 m 16V

Faisceau pour feux arrière LC12T avec surmoulages coudés  
Cavo per fanali posteriori LC12T con connettore 90°  
Manguera para pilotos traseros LC12 con conector sobremoldeado 90°

■ = gauche - sinistra - derecha

## LED



24V

### BOITIER DE COMPATIBILITÉ LED VIGNAL - EQUIPAGGIAMENTO DI COMPATIBILITÀ VIGNAL LED - CAJA DE COMPATIBILIDAD VIGNAL LED



Fonctions testées : position droit, position gauche, stop

**D13237** fils nus - estremità cavo nuda - cable pelado

**D13502** pour module de jonction - per scatola di derivazione - para caja de derivación

**D13234** RSC Vignal 16 voies - vie - polos

**D13235** RSC Vignal 15 voies - vie - polos

## MDJ

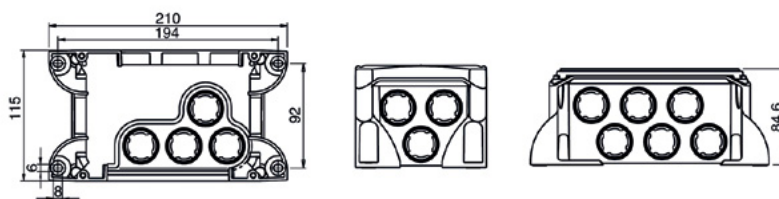

### SYSTÈME MDJ - SISTEMA SCATOLA DI DERIVAZIONE - SISTEMA CAJA



**175020**

**D11889**



**175086** cable Ø 5,9-6,9

**177136** cable Ø 8,3-10

**175096** cable Ø 11-12

## FCA

Pour feux arrière type LCR19 p.146

Per fanali posteriori LCR19 p.146

Para pilotos traseros LCR19 p.146



**NEW**

**D14984**

**AMP-MCP-4P-F**



**D14980**

**AMP-MCP-4P-F**

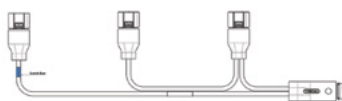

**AMP 1.5-7P-M**

**D14983**

**AMP-MCP-4P-F**

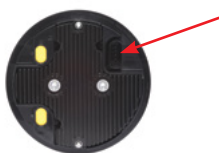

Affectations constructeurs  
Applicazione primo impianto  
Afectación primer equipo

SCHMITZ p.117

**AMP-MCP-4P-F**

**AMP-MCP-4P-F**

**AMP-MCP-4P-F**

**AMP-MCP-4P-F**



**D14846**

**HDSCS-6P-F**

gauche - sinistra - izquierda

**D14847**

**HDSCS-6P-F**

droit - destra - derecha

**D14884**

**HDSCS-6P-F**

gauche - sinistra - izquierda

**D14885**

**HDSCS-6P-F**

droit - destra - derecha



## CÂBLES FEUX ARRIÈRE - CAVI PER FANALI POSTERIORI - CABLES PARA PILOTOS TRASEROS



AMP 1.5

Pour feux arrière type LC5, LC6, LC7, LC8, LC9, LC12 p.138

Per fanali posteriori LC5, LC6, LC7, LC8, LC9, LC12 p.138

Para pilotos traseros LC5, LC6, LC7, LC8, LC9, LC12 p.138



AMP 1.5-7P-F

**D11626** 2500 mm

**D11627** 4300 mm

Pour module de jonction 175020  
Per scatola di derivazione 175020  
Para caja de derivación 175020



AMP 1.5-7P-F

**D11628** 2500 mm

Fils nus  
Estremità cavo nuda  
Cable pelado

AMP 1.5

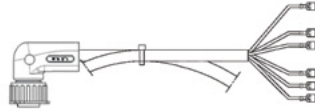

AMP 1.5-7P-F

**280049** 4000 mm

Fils nus  
Estremità cavo nuda  
Cable pelado

## RALLONGES - PROLUNGA - ALARGADORES



AMP 1.5-7P-M

AMP 1.5-7P-F

**D12449** 1000 mm

**D12450** 2000 mm

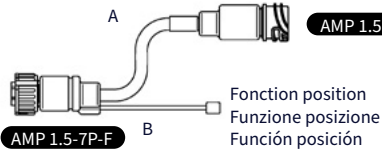

AMP 1.5-7P-M

AMP 1.5-7P-F

**R12575** A: 3 m / B: 3 m

**R12576\*** A: 0,5 m / B: 3 m

\* Pour / Per / Para LC9 p. 167



## DOUBLEUR DE FEUX - CAVO PER DOPPI FANALI POSTERIORI - MANGUERA PARA DOBLES PILOTOS TRASEROS



AMP 1.5-7P-F

AMP 1.5-7P-M

**D11689** 500 mm



## FCA



### CAPOT DE PROTECTION - PROTEZIONE - PROTECCIÓN

175 mm x 68 mm x 52 mm



#### D14721

Capot de protection pour connectique coudée feu arrière  
 Protezione per fanali posteriori con connettori 90°  
 Protección para piloto trasero con conector 90°

195 mm x 70 mm x 113 mm



#### D13725

Capot de protection pour connectique droite feu arrière  
 Protezione per fanali posteriori con connettori dritto  
 Protección para piloto trasero con conector recto

## KIT



### KITS DE RÉPARATION POUR FEUX ARRIÈRE - KIT DI REPARAZIONE PER FANALI POSTERIORI - KIT DE REPARACIÓN PARA PILOTOS TRASEROS



#### D11868

AMP 1.5-7P-F

Connecteur AMP 1.5 simple  
 Connettore AMP 1.5 singolo  
 Conector AMP 1.5 simple



#### D11865

500 mm

Connecteur AMP 1.5 avec câble plat  
 Connettore AMP 1.5 con cavo piatto  
 Conector AMP 1.5 con manguera plana



ADR



AMP JPT

Pour éclairateurs de plaque EPP98 p. 181 et feux de position SMD98, FE98 et FPL93 p. 197

Per luce targa EPP98 p. 181 e luce di posizione SMD98, FE98 e FPL93 p. 197

Para piloto iluminación de placa EPP98 p. 181 y piloto de posición SMD98, FE98 y FPL93 p. 197



### CÂBLES FEUX LATÉRAUX - CAVO LUCI DI POSIZIONE - CABLES PARA PILOTOS DE POSICIÓN AMP JPT



JPT-2P-F

**280009** A : 2 m

**280019** A : 4 m

**280029** A : 6 m

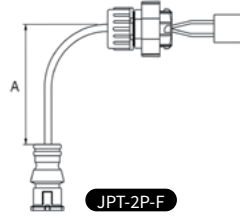

Pour / Per / Para  
MDJ 175020

JPT-2P-F

**280039** A : 4 m

Fils nus  
Estremità cavo nuda  
Cable pelado

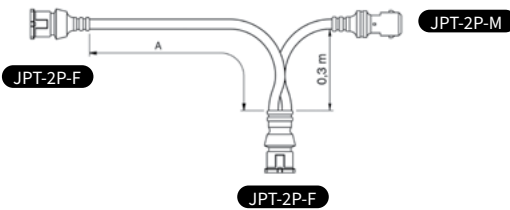

JPT-2P-F

JPT-2P-M

JPT-2P-F

**280059** A : 3,5 m

**280069** A : 5,5 m

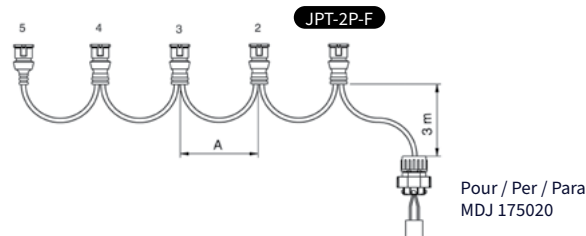

JPT-2P-F

Pour / Per / Para  
MDJ 175020

3 x JPT	<b>280089</b>	A : 3,5 m	<b>280129</b>	A : 5,5 m
4 x JPT	<b>280099</b>	A : 3,5 m	<b>280139</b>	A : 5,5 m
5 x JPT	<b>280109</b>	A : 3,5 m	<b>280149</b>	A : 5,5 m

## KIT

### KITS DE RÉPARATION POUR FEUX LATÉRAUX - KIT DI REPARAZIONE PER LUCI LATERALI - KIT DE REPARACIÓN PARA PILOTOS LATERALES

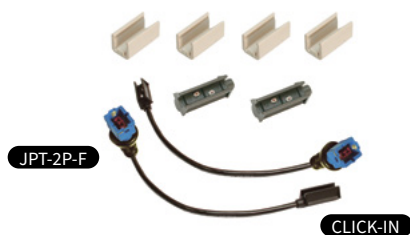

JPT-2P-F

CLICK-IN

**001796** 500 mm

**001806** 1500 mm



CLICK-IN

**001786** 500 mm



**D13876**

JPT-2P-F

Connecteur JPT 2 voies  
Connettore JPT 2 vie  
Conector JPT 2 vías



### CÂBLES FEUX LATÉRAUX - CAVO LUCI DI POSIZIONE - CABLES PARA PILOTOS DE POSICIÓN SUPERSEAL

ADR



SUPERSEAL

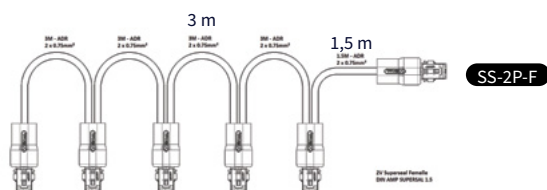

**R14173** 17,5 m

Pour éclairage de plaque LPL18, EPP96LED p. 179 et feux de position SMD98, DX p. 197

Per luce targa LPL18, EPP96LED p. 179 e luce di posizione SMD98, DX p. 197

Para piloto iluminación de placa LPL18, EPP96LED p. 179 y piloto de posición SMD98, DX p. 197

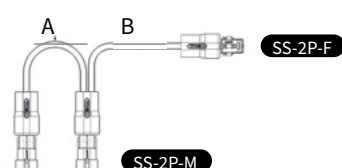

**R14418** A : 300 mm/ B:500 mm



**R14426** 1500 mm

Rallonge SUPERSEAL 2 voies  
Prolunga SUPERSEAL 2 vie  
Alargador SUPERSEAL 2 vías



## KIT



### KITS DE RÉPARATION POUR FEUX LATÉRAUX - KIT DI REPARAZIONE PER LUCI LATERALI - KIT DE REPARACIÓN PARA PILOTOS LATERALES



**D13880**

SS-2P-F

Connecteur SUPERSEAL 2 voies femelle  
Connettore SUPERSEAL 2 vie femmina  
Conector SUPERSEAL 2 vías hembra

Pour / Per / Para  
SMD98, FPL93, LC12, ICDL10,  
LPL18



**D14208**

SS-2P-M

Connecteur SUPERSEAL 2 voies mâle  
Connettore SUPERSEAL 2 vie maschio  
Conector SUPERSEAL 2 vías macho



Câble plat  
Cavo piatto  
Manguera plana



**D11268** 16 m

**A10779** 100 m

Câble plat - Cavo piatto - cable plano



POS-2P-F

**D11147** 500 mm

Pour / Per / Para  
LC8T



Câble plat optionnel avec connecteur 2 voies  
pour repiquage sur feu arrière LC8

Cavo piatto opzionale con connettore a 2 vie per  
collegamento su fanale posteriore LC8

Manguera plana opcional con conector 2 vías  
para acoplamiento con piloto trasero LC8

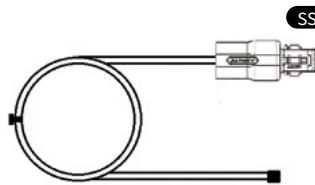

SS-2P-F

Pour / Per / Para  
LC12T



**R14412** 16 m

Câble plat optionnel avec connecteur 2 voies  
SUPERSEAL pour repiquage sur feu arrière LC12T

Cavo piatto opzionale con connettore a 2 vie SU-  
PERSEAL per collegamento su fanale posteriore  
LC12T

Manguera plana opcional con conector 2 vías  
SUPERSEAL para acoplamiento con piloto trasero  
LC12T

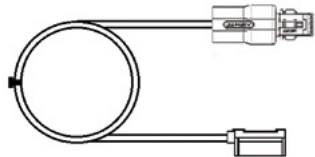

SS-2P-F

CLICK-IN

**R14416** 1500 mm

Pour / Per / Para  
CTL15



**R14339** 7,5 m

4V DT

Pour / Per / Para  
BL15



**R14338** 7,5 m

4V DT





CLICK-IN

**D10517** 500 mm

**D10518** 1500 mm

**D10519** 3500 mm



CLICK-IN

**D10132** 200 mm



**151236**

Verrou pour click-in à usage unique  
Morsetto click-in per uso unico  
Abrazadera para click-in con uso único



**001826**

Obtuteur seal-in  
Protezione per seal-in  
Protección para seal-in



**9115118**

Pince pour click-in  
Pinze per click-in  
Alicates para click-in



**4330012**

Bouchon pour câble plat  
Tappo per cavo piatto  
Tapón para cable plano



**D13251** 1 Kg

Graisse anti-corrosion  
Lubrificante anti-corrosione  
Lubrificante anti-corrosión

# Systemes câblage et feux

## Kit cablaggi e fanali

## Sistemas cableados y iluminación

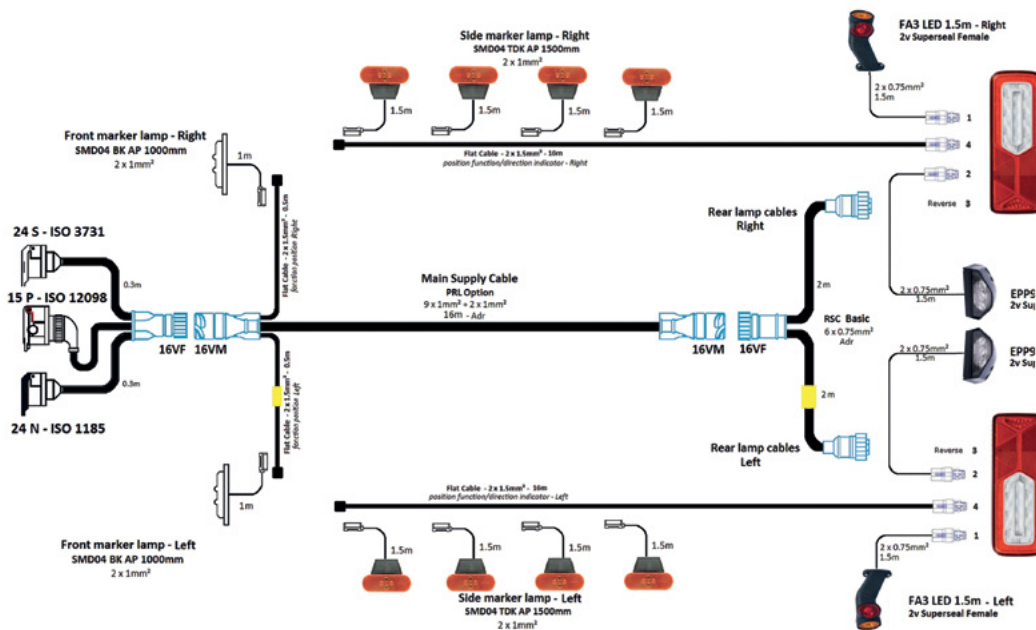

Flashez le QR code pour plus d'infos  
Scansiona il codice QR per maggiori informazioni  
Escanee el código QR para obtener más info

AMP 1.5-7P-M

Type connecteur - Nb pins - Mâle ou Femelle  
Tipo di connettore - Num pin - Maschio o Femmina  
Tipo de conector - Num pines - macho o hembra

## KITS COMPLETS LED - KIT COMPLETO LED - KITS COMPLETOS LED

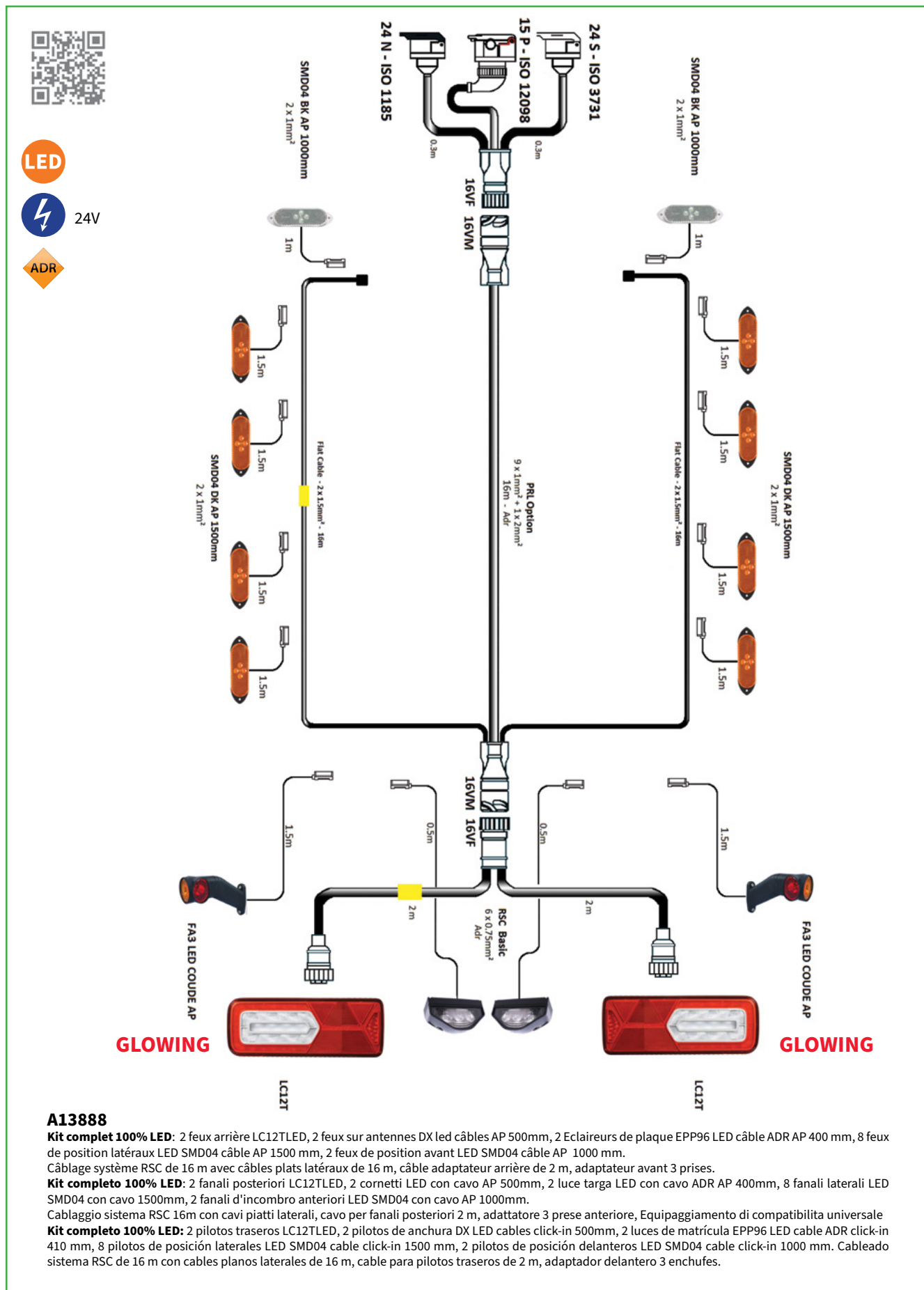

## KITS COMPLETS LED - KIT COMPLETO LED - KITS COMPLETOS LED



FEUX DE POSITION LATÉRAUX LED CLIGNOTANTS gestion selon supplément 6 - R48  
 LUCI LATERALI LED LAMPEGGIANTI gestione secondo supplemento 6 - R48  
 PILOTOS DE POSICION LED INTERMITENTES según suplemento 6 - R48

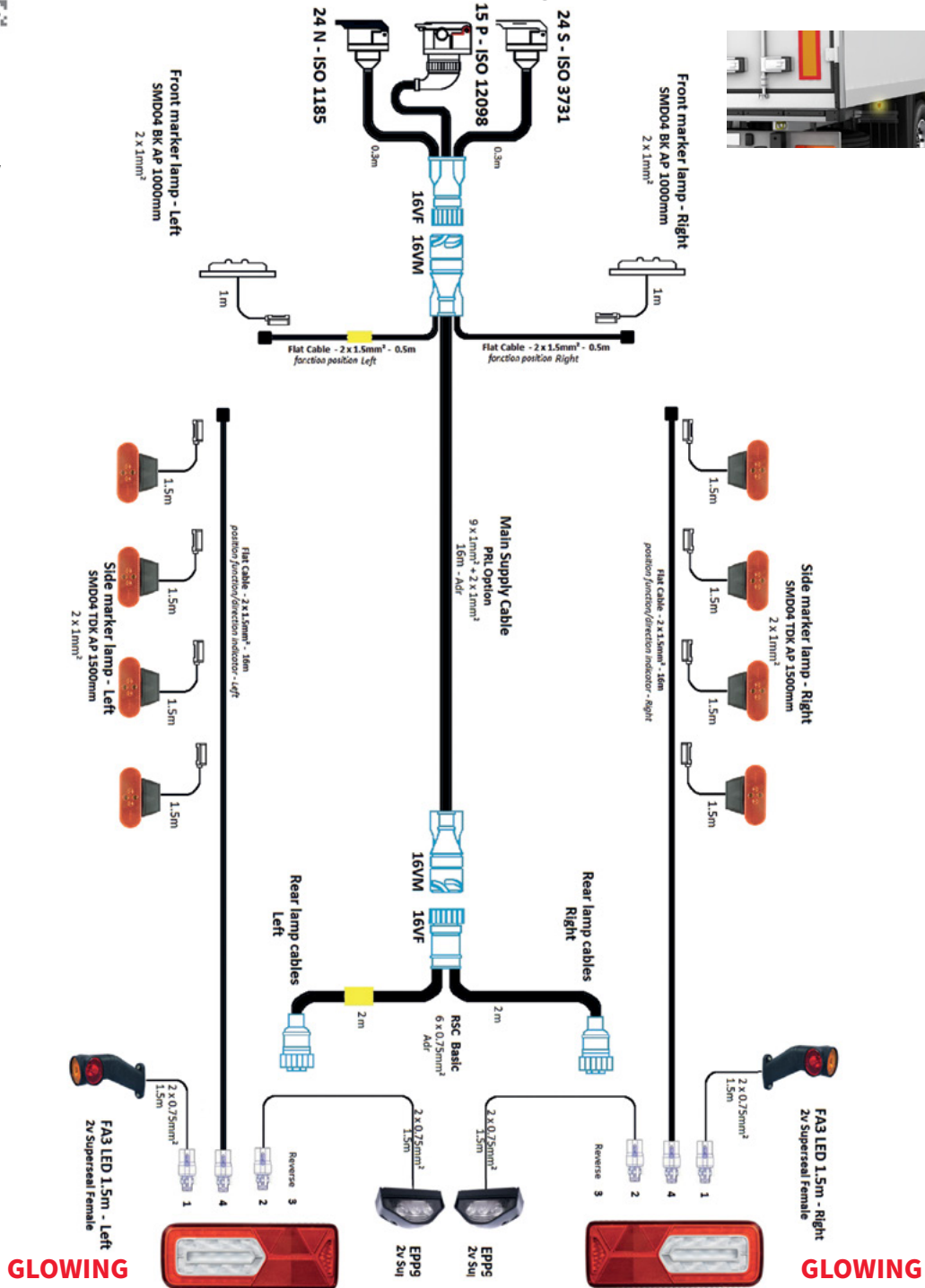
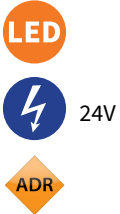

### A14366

**Kit complet 100% LED** : 2 feux arrière LC12TLED, 2 feux sur antennes DX led câbles SS 1,5 m, 2 Eclaireurs de plaque EPP96 LED câble ADR SS 1,5 m, 8 feux de position latéraux clignotants LED SMD04 câble AP 1500 mm, 2 feux de position avant LED SMD04 câble AP 1000 mm.  
 Cablage système RSC de 16 m avec câbles plats latéraux de 16 m connectique SS, câble adaptateur arrière de 2 m, adaptateur avant 3 prises.

**Kit completo 100% LED**: 2 fanali posteriori LC12TLED, 2 cornetti LED con cavo SS 1,5m, 2 luce targa LED con cavo ADR SS 1,5m, 8 fanali laterali lampeggianti LED SMD04 con cavo 1500mm, 2 fanali d'incombros anteriori LED SMD04 con cavo AP 1000mm.  
 Cablaggio sistema RSC 16m con cavi piatti laterali conettori SS, cavo per fanali posteriori 2 m, adattatore 3 prese anteriore, Equipaggiamento di compatibilità universale

**Kit completo 100% LED**: 2 pilotos traseros LC12TLED, 2 pilotos de anchura DX LED cables SS 1,5 m, 2 luces de matrícula EPP96 LED cable SS 1,5m, 8 pilotos de posición laterales intermitentes LED SMD04 cable click-in 1500 mm, 2 pilotos de posición delanteros LED SMD04 cable click-in 1000 mm. Cableado sistema RSC de 16 m con cables planos laterales de 16 m conector SS, cable para pilotos traseros de 2 m, adaptador delantero 3 enchufes.

KITS COMPLETS - KIT COMPLETO - KITS COMPLETOS



24V

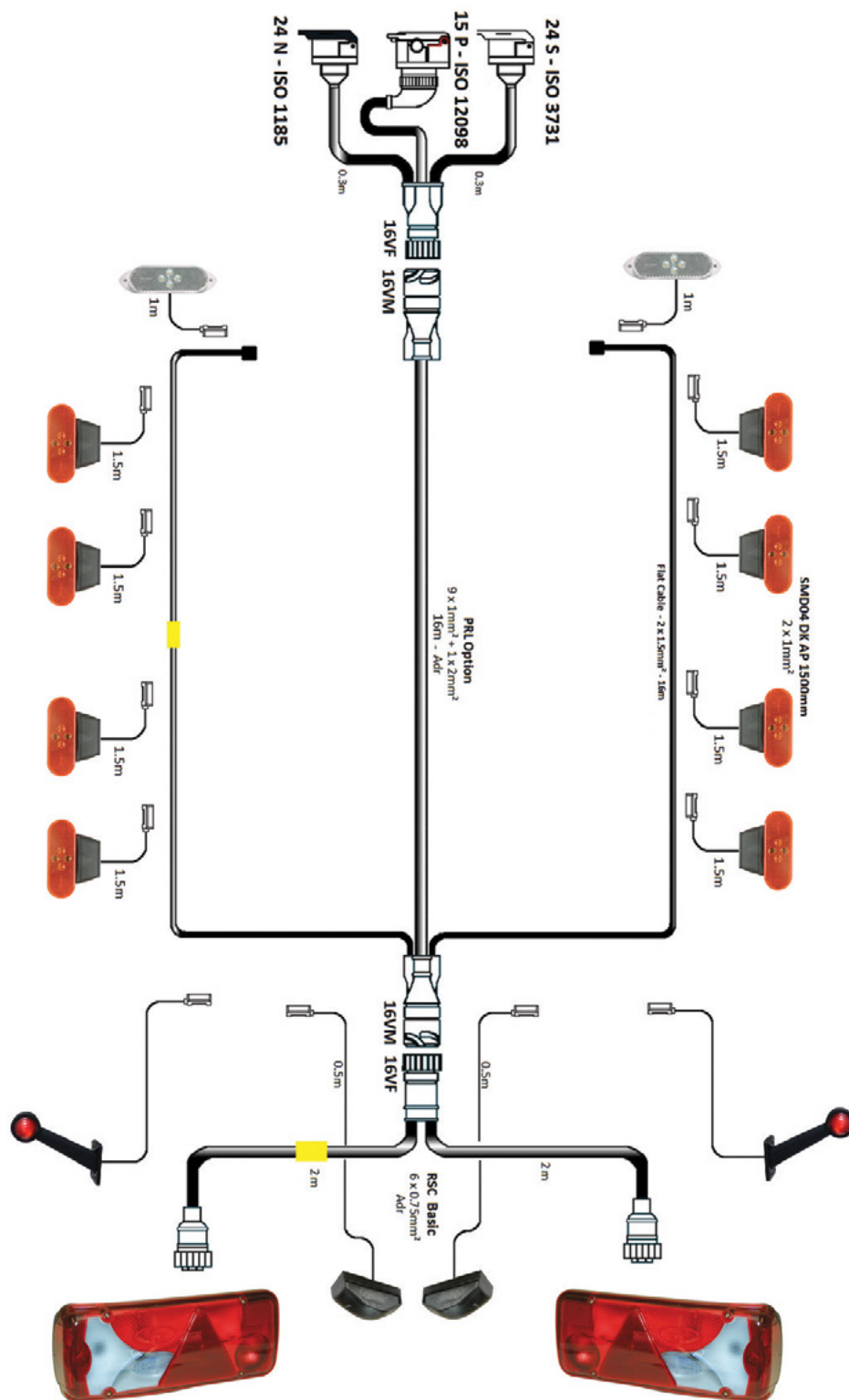

## A11212

**Kit complet :** 2 feux arrière LC8T, 2 feux sur antennes DX câbles AP 600mm, 2 Eclairage de plaque EPP96 câble ADR AP 410 mm, 8 feux de position latéraux LED SMD04 bride coudée câble AP 1500 mm, 2 feux de position avant LED SMD04 câble AP 1000 mm.

Câblage système RSC de 16 m avec câbles plats latéraux de 16 m, câble adaptateur arrière de 2 m, adaptateur avant 3 prises

**Kit completo :** 2 fanali posteriori LC8T, 2 cornetti con cavo AP 600mm, 2 luce targa con cavo ADR AP 410mm, 8 fanali laterali LED SMD04 con braccio 90° con cavo 1500mm, 2 fanali d'incombros anteriori LED SMD04 con cavo AP 1000mm.

Cablaggio sistema RSC 16m con cavi piatti laterale, cavo per fanali posteriori 2 m, adattatore 3 prese anteriore

**Kit completo :** 2 pilotos traseros LC8T, 2 pilotos de anchura DX cables click-in 600mm, 2 luces de matrícula EPP96 cable ADR click-in 410 mm, 8 pilotos de posición laterales LED SMD04 soporte 90° cable click-in 1500 mm, 2 pilotos de posición delanteros LED SMD04 cable click-in 1000 mm. Cableado sistema RSC de 16 m con cables planos laterales de 16 m, cable para pilotos traseros de 2 m, adaptador delantero 3 enchufes

## KITS COMPLETS LED 13P - KIT COMPLETO LED 13P - KITS COMPLETOS LED 13P



12V

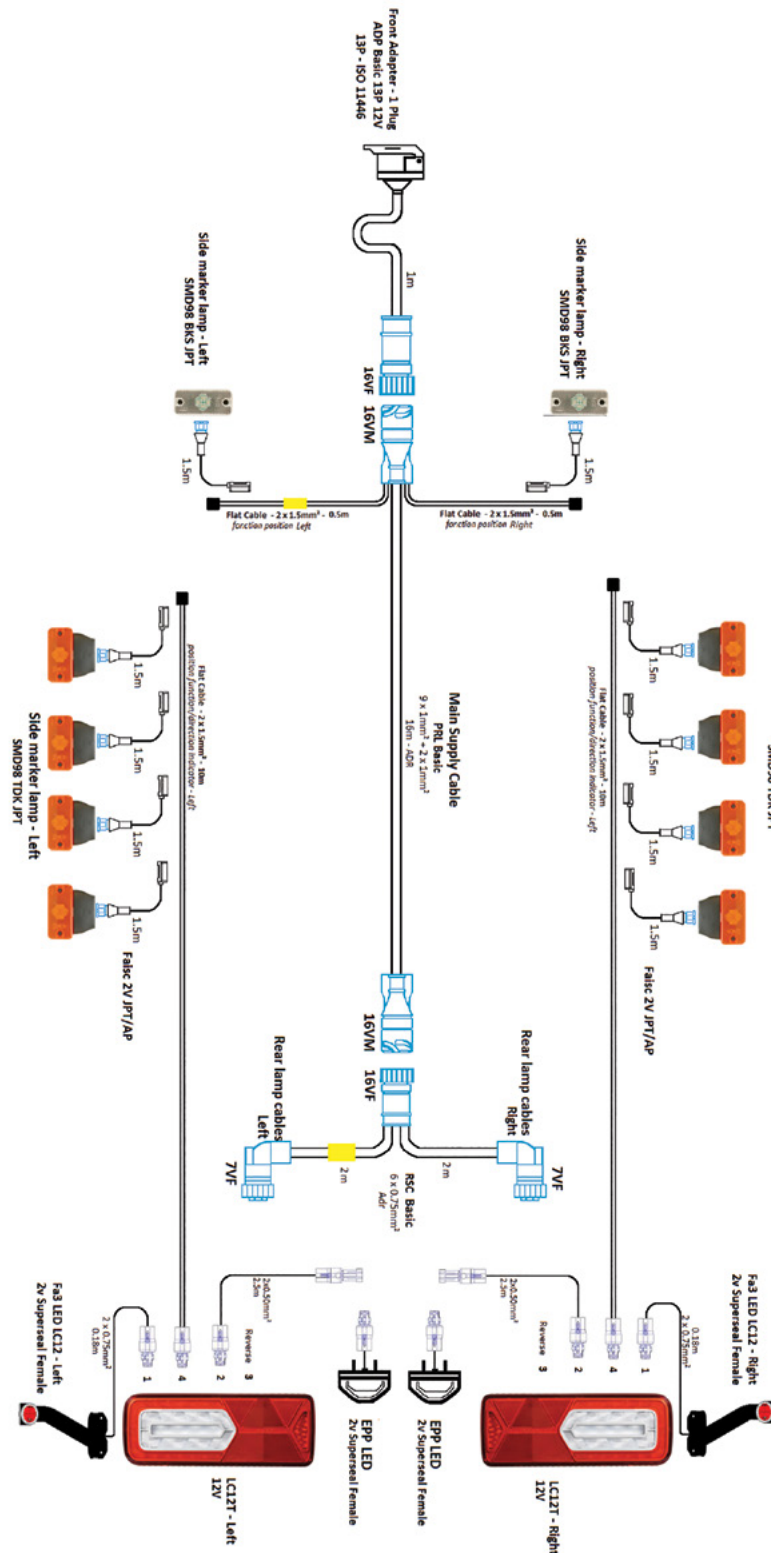

**NEW**

### A14838

**Kit complet 100% LED 12V** : 2 feux arrière LC12TLED, 2 feux sur antennes FA3 LC12 led câbles SS 1,8 m, 2 Eclairers de plaque BX868 LED câble ADR SS 2 m, 8 feux de position latéraux clignotants LED SMD98 + câble AP 1500 mm, 2 feux de position avant LED SMD98 + câble AP 1500 mm. Câblage système RSC de 16 m, câbles plats latéraux de 10 m connectique SS, câble adaptateur arrière de 2 m, adaptateur avant 13P ISO1724.

**Kit completo 100% LED**: 2 fanali posteriori LC12TLED, 2 cornetti FA3 LC12 led con cavo SS 1,8m, 2 luce targa BX868 LED con cavo ADR SS 2 m, 8 fanali laterali lampeggianti LED SMD98 + cavo 1500mm, 2 fanali d'incombro anteriori LED SMD98 + cavo AP 1500mm. Cablaggio sistema RSC 16m, cavi piatti laterali connettori SS 10m, cavo per fanali posteriori 2 m, adattatore anteriore 13P ISO1724.

**Kit completo 100% LED**: 2 pilotos traseros LC12TLED, 2 pilotos de anchura FA3 LC12 led cables SS 1,8 m, 2 luces de matrícula BX868 LED cable SS 2 m, 8 pilotos de posición laterales intermitentes LED SMD98 + cable click-in 1500 mm, 2 pilotos de posición delanteros LED SMD98 + cable click-in 1500 mm. Cableado sistema RSC de 16 m, cables planos laterales de 10 m conector SS, cable para pilotos traseros de 2 m, adaptador delantero 13P ISO1724.

## KITS COMPLETS LED 7P - KIT COMPLETO LED 7P - KITS COMPLETOS LED 7P



LED

12V

ADR

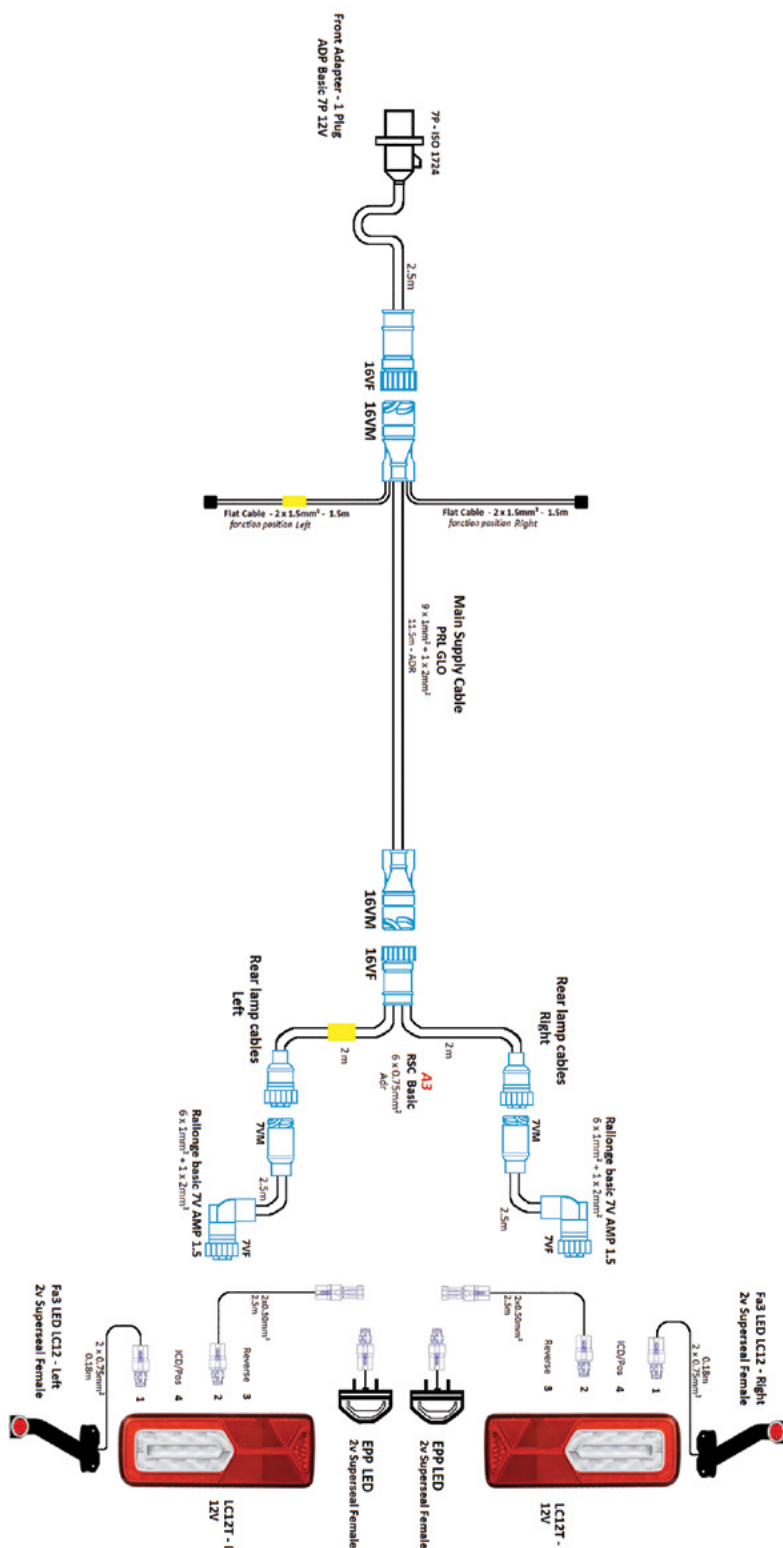

**NEW**

### A14715

**Kit complet 100% LED 12V :** 2 feux arrière LC12TLED, 2 feux sur antennes FA3 LC12 led câbles SS 1,8 m, 2 Eclairers de plaque BX868 LED câble ADR SS 2 m. Câblage système RSC de 11,5 m, câbles plats latéraux de 1,5 m connectique SS, câble adaptateur arrière de 2 m, adaptateur avant 7P ISO1724.

**Kit completo 100% LED:** 2 fanali posteriori LC12TLED, 2 cornetti FA3 LC12 led con cavo SS 1,8m, 2 luce targa BX868 LED con cavo ADR SS 2 m. Cablaggio sistema RSC 11,5 m, cavi piatti laterali connettori SS 1,5m, cavo per fanali posteriori 2 m, adattatore anteriore 7P ISO1724.

**Kit completo 100% LED:** 2 pilotos traseros LC12TLED, 2 pilotos de anchura FA3 LC12 led cables SS 1,8 m, 2 luces de matrícula BX868 LED cable SS 2m. Cableado sistema RSC de 11,5 m, cables planos laterales de 1,5 m conector SS, cable para pilotos traseros de 2 m, adaptador delantero 7P ISO1724.

# Index : Liste de correspondance - Codici costruttore - Referencias cruzadas

	OES	VIGNAL		OES	VIGNAL
BOBCAT	728786	R12931	HEULIEZ	2773801	167150
	7027476	052500		2870801	167150
	7028787	R12934		3156201	067000
	7164110	152150		0190408700	181000
	7164111	152150		0190552400	181050
	7175124	196010		190825600	193020
	7322387	161140		5010104837	185050
	7322388	161150		5010217022	185020
	7322390	D14488		5010271501	195030
	7348957	D14324		5010312524	195060
	7348958	D14325			
	7387145	D14854			
	CASE	5141966		198810	IVECO
47363002		199000	1608352	001726	
47826594		D14191	41200664	193170	
875884890		D14156	41221040	119930	
			41221041	119920	
CLAAS	27108471	212400	42535711	052500	
	7700027564	196020	42555041	110530	
DAF	0698603	040500	42555042	110520	
	0867930	196010	42555131	D12337	
	1272653	067500	42555132	D12336	
	1284211	167640	42566495	052500	
	1284212	167630	47363002	199000	
	1284213	168100	69500026	D12335	
	1284214	168390	69500032	D12334	
	1304788	168010	69500044	D12341	
	1304789	168020	69500047	D12340	
	1329718	193020	69500590	D12339	
	1401713	152170	69500591	D12338	
	1401731	152180	93161844	067500	
	1403887	195010	97163920	119550	
	1451482	052500	99463242	168600	
	1519368	D12953	99463243	168590	
	1608352	001726	99463244	168610	
	1625985	169160	500308514	193020	
	1625986	169170	500341613	198060	
	1626101	119550	500356782	D11481	
	1626102	001616	500356783	D11482	
	1626319	168100	504097923	193290	
	1626320	168390	580224029	160120	
	1653605	193200	5001834568	001616	
	1660967	168890	5801363428	169390	
	1660968	169380	5801363430	169400	
	1814096	109010	5801363431	169410	
	1815754	109010	5801363432	169420	
	1846491	117000	5801426889	153220	
	1846492	117010	5801426894	153210	
	1875576	155110	5801426912	153200	
	1875577	155100	5801426917	153230	
	1875578	155120	5801426975	153240	
	1875579	155140	5801426977	153250	
	1875580	155130	5801426979	153260	
	1875581	155150	5801572018	110560	
	1914690	055020	5801572024	110550	
	1914691	055030	5801631615	198760	
1973239	001830	5801637182	155480		
2922224	141500	5801637199	155450		
		5801637201	155460		
		5801637202	155470		
		5801757326	155500		
		5801757328	155490		
		5802000568	160080		
		5802000570	160110		
		5802000573	160100		
		5802000767	160090		
		5802000770	160130		
FIAT	1305797	193170			
	71749250	193360			
	1356794080	193360			
	1372698080	153280			
	1372699080	153270			



# Index : Liste de correspondance - Codici costruttore - Referencias cruzadas

	OES	VIGNAL		OES	VIGNAL	
IVECO	5802000772	160120	MANITOU	223767	152180	
	5802055272	155540		227330	D14517	
	5802055273	160140		564744	052500	
	5802062689	160150		661973	152180	
	5802240291	160150		959694	D14380	
	5802240292	160080		959695	D14381	
	5802240293	160110		52562043	D14380	
	5802240294	160140		52562044	D14381	
	5802240295	160100				
	5802240296	160090		MANITOWOC	03137250	156860
	5802240297	160130			03137251	156870
	A610067-002	052500			03137254	001830
	R504083205	168480			03138527	198660
					03320937	198520
					03320938	152180
	IVECO BUS	504217797		198650		03320939
5000461058		181000		03329492	198640	
5000461059		181050		03329572	D10493	
5001020257		119550				
5001834505		195030	MERCEDES	A 000 826 20 56	056540	
5001834564		001606	DAIMLER	A 000 826 21 56	056550	
5001834568		001616		A 906 820 04 64	156340	
5001834576		195060		A 906 820 17 64	156350	
5001837993		001626		A 910 206 29 00	212010	
5001847589		001726		A 910 820 64 00	160400	
5010104837		185050		A 910 820 65 00	160410	
5010179915		167150		A 910 826 10 00	060000	
5010197259		191170		A 910 826 11 00	060010	
5010197260		191110		A 910 906 36 00	212010	
5010197261		191140		A 910 906 69 00	212420	
5010197262		191120		A 949 540 01 04	196170	
5010217022		185020		A 956 544 00 11	198780	
5010286898		195000		A 956 820 00 59	116200	
5010306792		193020		A 959 544 01 03	155590	
50101972564		191150		A 959 544 02 03	155600	
			A 959 544 03 03	155610		
			A 960 820 02 58	212700		
KUBOTA	W20TS00777	D14513	MERLO	115855	D14479	
	W20TS01401	D14749		115856	D14513	
	W20TS01684	D14725		116119	D14508	
LECAPITAINE	661012	D11689				
	661058	164050				
MAN	7CE945095	155550	NEW HOLLAND	5141966	198810	
	7CE945096	155560		47363002	199000	
	81.25207-6074	212020		47826594	D14191	
	81.25207-6075	212030		51431987	D14654	
	8125225-6033	168090	NISSAN	26164-9X402	119550	
	8125225-6034	168100		26244-9X400	001616	
	8125225-6464	168090		26554-9X126	052500	
	8125225-6469	166700		26555-9X125	152180	
	8125225-6470	166700		26555-9X126	152170	
	8125225-6523	169170		26555-9X128	153120	
	8125225-6524	169160	OPEL	4421269	196010	
	8125225-6526	169180		4421265/6	152180	
	8125225-6528	168490	PEUGEOT CITROËN	9815126980	153280	
	8125225-6530	169190		9815127080	153270	
	8125225-6544	156200		63501FS	153280	
	8125225-6545	156210		6350FS	153270	
	8125225-6547	156220	RENAULT TRUCKS	23811106	212740	
	8125229-6051	067500		23811107	212750	
	8125229-6059	056500		5000296591	166000	
	8125229-6060	056510		5000296591	166100	
MANITOU	163782	500930				
	163783	500940				

# Index : Liste de correspondance - Codici costruttore - Referencias cruzadas

	OES	VIGNAL		OES	VIGNAL
RENAULT TRUCKS	5000296592	167000	RENAULT TRUCKS	7421430181	104570
	5000296592	167100		7422800385	158030
	5000296593	066000		7422800386	158040
	5000296594	067000		7422800391	058000
	5000296718	088010		7423080010	158050
	5000461058	181000		7423292490	059500
	5000461059	181050		7423374865	D10596
	5000623050	188310		7423467438	159520
	5000807304	040000		7423530438	159520
	5000808166	040500		7423530440	159500
	5000808171	141000		7423530441	159510
	5000808172	141500		7423530442	159530
	5001831194	168220		7425982261	158030
	5001832999	168260		7482252291	115040
	5001834561	195010		7482252506	115000
	5001834565	119450		7482255014	115030
	5001834568	001616		7482266219	113020
	5001835853	168140		7482285707	113030
	5001846843	152000		7482346591	115020
	5001846844	152010		7482367030	115010
	5001846845	152040		7482392733	198620
	5001846846	152050		7482522006	104570
	5001846847	152020		7482586940	198740
	5001846848	152030		7484185589	D14161
	5001846849	152060		7484538758	193020
	5001846850	152070		7484585204	158040
	5001847153	052500		7484585206	158050
	5001847582	169060		7484585208	158030
	5001847583	169070		7485118470	152170
	5001847584	169000		7700353021	196020
	5001847585	169010		7700377130	D14590
	5001847586	169020		7700377208	198510
	5001847587	169030		8200602314	D14593
	5001847588	067500		265100848R	196010
	5001847589	001726		265500292R	152180
	5001847597	119470		265504514R	152180
	5001857964	152510		265550674R	152180
	5001857965	152520		265551402R	152180
	5001858092	152500			
	5001858093	152600	SCANIA	1350343	067500
	5001862030	102200		1365963	168350
	5001862030	193200		1365964	168360
	5001864535	169310		1756751	156780
	5001864536	169320		1756754	156770
	5001870556	152180		1784669	056540
	5010217022	185020		1784670	056550
	5010217023	185040		1791369	156790
	5010271807	185160		2020496	D10596
	5010293829	196010		2021575	156780
	5010306792	193020		2021576	156790
	5010392231	052000		2021578	155020
	5010595381	152170		2021579	156770
	5010595382	152180		2129985	156770
	7420802348	159010		2129986	155020
	7420802350	159020		2129987	156780
	7420802353	159030		2129988	156790
	7420802418	059000		2129991	056550
	7420862032	152880		2129992	056540
	7420862035	152880		2160127	155090
	7420862038	152190		2160128	155080
	7420862041	152200		2340796	155520
	7420894265	193280		2862201	D14852
	7421106206	198650			
	7421137718	104450	SCHMITZ	1302341	161000
	7421268609	191170		1302342	161010
	7421396991	D13019		1348566	D14488

# Index : Liste de correspondance - Codici costruttore - Referencias cruzadas

	OES	VIGNAL		OES	VIGNAL
SCHMITZ	1364736	161000	VOLVO	21735301	159520
	1364737	161010		23354972	158030
	1370066	161280		23354973	158040
	1370067	161290		23354974	158050
	1415545	213010		23522304	159520
	1415546	213090		23522305	159530
STEYR	48159167	D14156	23522307	159500	
	51431987	D14654	23522308	159510	
			23690764	159520	
UD TRUCKS	84655961	120000	23690765	159530	
	261319Z01B	153860	23690769	159500	
	261319Z01C	153870	23742314	212730	
	261319Z01D	153880	82114500	107010	
	265109Z00A	196010	82114502	107050	
	265509Z00A	052500	82114504	107040	
VF VENIERI	101 1 102	D14548	82114506	107000	
	101 2 421	D14478	82116545	207000	
	101 4 211	D14509	82150539	114010	
	101 4 681	D14508	82151157	111000	
	101 4 734	D14324	82151205	111010	
	101 4 735	D14325	82202076	113000	
VOLKSWAGEN	2E0 945 095 A	156340	82278930	112010	
	2E0 945 096 A	156350	82278938	112000	
	2E0 945 111 A	056540	82348508	116040	
	2E0 945 112 A	056550	82349220	116010	
	7CA 945 091	152180	82349221	116000	
	7CA 945 092	152180	82355678	107000	
	7CA945095	155570	82355684	107010	
	7CA945096	155580	82467736	107500	
			82467737	107510	
VOLVO	20537280	052000	82483073	159510	
	20717520	102200	82483074	159500	
	20721495	196010	82849894	158030	
	20734485	193020	82849905	058000	
	20745060	052500	82849923	158050	
	20745066	001726	82849925	158040	
	20745225	195010	84044658	198740	
	20745227	001616	84122332	059500	
	20769775	159010	84139927	107000	
	20769776	159020	84139939	107010	
	20769777	159030	84185589	D14161	
	20769781	152880	84195505	158030	
	20769782	152880	84195519	158040	
	20769783	152190	84195521	158050	
	20769784	152200	84441759	159500	
	20789440	198620	84441760	159510	
	20802418	059000	84441766	158030	
	20872890	D12111	84441767	158040	
	21087346	207010	84441768	158050	
	21087347	207020	84441936	159520	
	21214524	114020	84441937	159530	
	21214534	114000	84538758	193020	
	21341202	119550	85105029	001766	
	21346521	111020	VOLVO BUS	20480486	198650
	21346522	111030	70364301		198640
	21368779	116050	VOLVO CONSTRUCTION	11170068	198520
	21368781	116060	23374865		D10596
	21368782	116030			
	21368783	116020			
	21396991	D13019			
	21448885	107040			
	21478751	107050			
	21735299	159530			

# Index références - Indice riferimenti - Índice referencias

000046	171	094026	199	115030	88	153870	124
000086	188, 212	094036	192	115040	88	153880	124
000176	181, 192, 199, 204, 211,	094046	192	116000	129	153890	124
001586	52, 192, 199, 204	094056	204	116010	129	155020	115, 155
001596	192, 199, 204	094066	204	116020	129	155080	115, 155
001606	58	102200	193, 250	116030	129	155090	115, 155
001616	184, 187	104090	139, 196	116040	129	155100	23, 150
001619	183, 186	104100	139, 196	116050	129	155110	23, 150
001626	40, 54, 55, 56, 59	104130	191	116060	129	155120	23, 150
001696	191, 197, 199, 200, 203	104140	191	116200	78	155130	23, 150
001706	170	104170	202	117000	25, 186	155140	23, 150
001716	191, 197, 199, 200, 203	104180	202	117010	25, 186	155150	23, 150
001726	193, 200, 250	104210	196	119450	187	155450	44, 152
001766	130, 198	104220	196	119470	187	155460	44, 152
001786	309	104250	196	119550	187	155470	44, 152
001796	309	104260	196	119920	47, 183	155480	44, 152
001806	309	104290	190	119930	47, 183	155490	44, 152
001826	312	104300	190	120000	124, 186	155500	44, 152
001830	274	104310	190	141000	171	155520	115, 155
001846	158	104330	202	141500	171	155540	44, 152
001872	153, 274	104340	202	151236	312	155550	70, 153
001916	200	104360	202	152000	100, 104	155560	70, 153
014580	184	104450	190	152010	100	155570	126, 151
040000	171	104510	190	152020	95, 101, 105	155580	126, 151
040500	171	104520	191	152030	101	155590	76
052000	161	104570	190	152040	100	155600	76
052500	162, 163	104640	196	152050	100	155610	76
053700	164, 165	104650	196	152060	101	156040	157
053710	164, 165	104670	196	152070	101	156050	157
055020	150, 151	104680	202	152130	161	156060	157
055030	150, 151	104690	191	152140	161	156070	157
055040	152	104700	196	152150	161	156130	157
055050	152	104710	202	152160	161	156200	70, 153
056000	154	104720	191	152170	161	156210	70, 153
056010	154	107000	128, 131, 185	152180	161	156220	70, 153
056020	156	107010	128, 131, 185	152190	161	156250	32, 66, 159
056030	156	107040	128, 131, 185	152200	161	156260	32, 66, 159
056500	153, 154	107050	128, 131, 185	152500	95, 105	156290	154
056510	153, 154	107500	131, 185	152510	95, 105	156300	62, 154
056540	155, 156	107510	131, 185	152520	95, 105	156310	62, 154
056550	155, 156	109010	24, 186	152600	104	156340	77, 126, 156
056700	158	110520	183	152880	100, 104, 133	156350	77, 126, 156
056710	158	110530	183	153000	164	156380	66, 159
056720	159	110550	183	153010	164	156390	66, 159
056730	159	110560	183	153020	164	156540	20, 154
058000	142	111000	127, ,185	153030	164	156550	20, 154
059000	160	111010	127, ,185	153040	164	156590	156
059500	143	111020	127, ,185	153050	164	156600	156
060000	140, 141	111030	127, ,185	153060	164	156630	157
060010	140, 141	112000	128	153070	164	156640	157
066000	170	112010	128	153120	81, 161	156770	115, 155
066500	170	112110	211	153130	66, 164	156780	115, 155
067000	166, 167, 168	112120	211	153200	45, 163	156790	115, 155
067500	166, 167, 168	112130	211	153210	45, 163	156860	75
067600	169	112140	211	153220	45, 163	156870	75
067610	169	112710	211	153230	45, 163	158030	86, 127, 142
080026	195	112720	211	153240	45, 163	158040	86, 127, 142
080046	195	113000	129	153250	45, 163	158050	86, 127, 142
087020	194	113020	88	153260	45, 163	159010	87, 132, 160
087030	205	113030	88	153270	34, 85, 162	159020	87, 132, 160
087040	188, 201	114000	128	153280	34, 85, 162	159030	87, 132, 160
088010	211	114010	128	153660	165	159500	87, 99, 131, 143
094016	199	114020	128	153670	165	159510	87, 99, 131, 143
		115000	88	153700	165	159520	87, 99, 131, 143
		115010	88	153710	165	159530	87, 99, 131, 143
		115020	88	153860	124	160080	43, 140

# Index références - Indice riferimenti - Índice referencias

160090	43, 140	168390	27	193360	200	213070	146
160100	43, 140	168480	47, 167	194010	199	213090	117, 146
160110	43, 140	168490	71	194020	199	213150	146
160120	43, 140	168590	48, 51, 53, 167	194030	199	213160	146
160130	43, 140	168600	47, 51, 53, 167	194070	199	213200	146
160140	43, 140	168610	47, 48, 49, 167	194080	199	240346	216
160150	43, 140	168770	169	194090	199	240356	216
160400	77, 141	168780	169	194130	192	240366	216
160410	77, 141	168790	169	194140	192	241346	216
161000	138	168800	169	194150	192	241356	216
161010	138	168830	169	194190	192	241366	216
161120	138	168890	24	194250	204	280009	309
161130	138	169000	90, 94, 100	194260	204	280019	309
161140	14	169010	90, 94, 100	194270	204	280029	309
161150	14	169020	90, 94	194310	204	280039	309
161180	138	169030	90, 94	195000	58	280049	307
161190	138	169060	91, 96	195010	193	280059	309
161200	138	169070	91, 96	195030	193	280069	309
161210	138	169160	24, 71, 167	195060	205	280089	309
161260	61, 138	169170	24, 71, 167	196010	181	280099	309
161270	61, 138	169180	71, 167	196020	181	280109	309
161280	82, 117, 138	169190	71, 167	196170	181	280129	309
161290	82, 117, 138	169310	90, 94	198010	198	280139	309
161420	138	169320	90, 94	198020	198	280149	309
161430	138	169380	24	198030	198	300000	64, 250
161460	138	169390	46, 168	198040	192	300010	64, 250
161470	138	169400	46, 168	198050	192	500930	73, 175
161500	138	169410	46, 168	198060	203	500940	73, 175
161510	138	169420	46, 168	198510	197	521010	195
161560	138	175020	306	198520	197	521050	195
161570	138	175086	306	198530	197	610080	210
163010	148	175096	306	198540	197	611010	210
164000	19, 144	177136	306	198580	107	611020	210
164010	19, 65, 144	180010	195	198620	88, 130, 198	611070	295
164020	123, 144	180040	195	198640	203	611080	295
164030	123, 144	181000	212	198650	197	611110	295
164050	65	181050	188	198660	191	611140	295
165020	19, 65, 144, 229	181070	188	198690	191	611150	295
165030	19, 65, 144, 229	185010	194	198740	88, 130, 198	611410	296
165040	35, 123, 144, 229	185020	194	198760	78, 197	611500	294
165050	35, 123, 144, 229	185030	205	198810	197	611510	294
166000	170	185040	187	199000	16, 80, 179	611520	294
166100	170	185050	205	199020	179	611530	294
166500	39, 55	185160	187	199030	179	611540	294
166600	170	187120	194	199040	62, 179	611550	294
166700	72	187130	205	207000	129, 132	611560	297
167000	166	187140	188, 201	207010	129, 132	611570	297
167100	166	187720	194	207020	129, 132	611580	294
167150	39, 56	187730	205	212010	77, 253	611590	294
167500	166	187760	188, 201	212020	70, 252	624016	216
167530	169	188010	211	212030	70, 252	624026	216
167550	169	188110	211	212120	252	624036	216
167600	166	188210	211	212160	252	630100	274
167630	24	188310	211	212170	253	630110	274
167640	24	188610	211	212400	22, 252	630120	274
168010	24, 168	188710	211	212420	29, 77, 114, 252	672410	201
168020	24, 168	191110	59	212460	42, 252	725002	173, 174
168090	71, 166	191120	59	212470	252	725010	173
168100	27, 71, 166	191140	59	212520	74, 253	725012	173, 174
168140	95	191150	59	212560	253	725020	173
168220	91, 95, 112	191170	59, 102	212570	253	725022	173, 174
168260	91, 95, 112	193020	200	212710	76, 253	725032	173, 174
168270	166	193170	200	212730	130, 253	725040	173
168340	166	193200	193	212740	86, 253	726290	174
168350	116	193280	200	212750	86, 253	726300	174
168360	116	193290	200	213010	117, 146	726310	173

# Index références - Indice riferimenti - Índice referencias

726320	173	D11578	296	D13710	191	D14328	276
726350	174	D11626	307	D13713	197	D14331	301
726450	174	D11627	307	D13725	308	D14345	149
726460	174	D11628	307	D13807	274	D14347	277, 279
4330012	312	D11689	307	D13808	274	D14348	149
9115118	312	D11865	308	D13810	274	D14352	302
60760541	175	D11868	300, 308	D13816	149	D14353	272
60760551	175	D11888	181	D13817	148	D14354	272
67513361	175	D11889	306	D13860	272	D14357	239
67513371	175	D11899	210	D13862	272	D14358	239
67513380	175	D12111	130, 237	D13863	272	D14362	196, 301
67513390	175	D12334	50, 172	D13874	180	D14380	73
A10060	296	D12335	50, 172	D13875	207	D14381	73
A10061	296	D12336	50, 172	D13876	300, 309	D14387	228
A10062	297	D12337	50, 172	D13877	300	D14421	207
A10064	296	D12338	50	D13878	300	D14422	207
A10065	297	D12339	50	D13879	300	D14423	207
A10066	297	D12340	50	D13880	301, 310	D14424	207
A10779	311	D12341	50	D13881	282	D14425	139, 207
A11212	316	D12390	220	D13889	296	D14426	139, 207
A13888	314	D12428	209	D14030	207	D14427	207
A14366	315	D12429	209	D14031	207	D14428	207
A14420	123, 145	D12430	165, 209	D14034	207	D14429	207
A14715	318	D12449	307	D14035	207	D14430	207
A14838	317	D12450	307	D14037	158, 208	D14431	207
D10132	312	D12471	165, 209	D14038	158, 208	D14432	207
D10227	181	D12472	165, 209	D14039	158, 208	D14434	302
D10493	197	D12473	165, 209	D14040	158, 208	D14435	302
D10494	197	D12488	236	D14063	277	D14436	302
D10495	197	D12699	196	D14091	281	D14437	302
D10496	197	D12711	158, 209	D14116	180	D14447	227
D10497	197	D12712	158, 209	D14148	282	D14451	259
D10498	197	D12713	215	D14156	236	D14452	259
D10499	203	D12714	215	D14159	236	D14453	259
D10500	191	D12715	215	D14160	227	D14454	262
D10502	181	D12867	197	D14161	227	D14455	262
D10503	210	D12953	160, 168, 274	D14165	247	D14456	262
D10504	304	D13019	237	D14166	247	D14457	262
D10505	304	D13034	158, 209	D14167	246	D14462	260
D10508	304	D13035	158, 209	D14170	301	D14463	260
D10510	304	D13205	215	D14188	149	D14464	260
D10513	305	D13206	215	D14189	149	D14465	260
D10514	305	D13207	215	D14190	272	D14466	260
D10515	305	D13234	305	D14191	234	D14467	261
D10517	312	D13235	305	D14192	234	D14468	261
D10518	312	D13237	305	D14195	277, 279	D14469	261
D10519	312	D13249	304	D14208	301, 210	D14470	261
D10596	217	D13250	304	D14214	300	D14471	261
D10597	297	D13251	312	D14216	277	D14472	267
D10642	210	D13254	304	D14236	277	D14473	267
D10643	210	D13255	304	D14249	239	D14474	267
D10800	210	D13256	304	D14250	239	D14475	262
D10839	176	D13257	304	D14311	297	D14476	262
D10840	176	D13260	304	D14312	295	D14477	261
D10841	176	D13262	305	D14313	295	D14478	261
D10873	294	D13263	304	D14314	295	D14479	261
D10874	294	D13277	210	D14315	296	D14480	261
D11147	210, 311	D13288	161	D14316	295	D14481	262
D11268	190, 311	D13502	305	D14320	243	D14482	257
D11399	191	D13609	180	D14321	243	D14483	257
D11400	203	D13610	180	D14322	243	D14484	257
D11479	50, 172	D13617	282	D14323	243	D14485	257
D11480	50, 172	D13620	283, 285	D14324	242	D14486	257
D11481	50, 172	D13621	283, 285, 288	D14325	242	D14487	255
D11482	50, 172	D13622	283, 285, 288	D14326	277, 279	D14488	255
D11487	296	D13624	210	D14327	282	D14489	255

# Index références - Indice riferimenti - Índice referencias

D14490	255	D14578	296	D14749	260	D14935	270
D14491	255	D14587	216	D14750	260	D14942	298
D14492	255	D14588	216	D14751	260	D14943	298
D14493	255	D14589	216	D14752	255	D14944	298
D14494	255	D14590	216	D14753	255	D14945	298
D14495	255	D14591	216	D14754	255	D14947	298
D14496	255	D14592	216	D14755	255	D14948	298
D14500	254	D14593	216	D14756	254	D14949	298
D14501	254	D14594	216	D14757	254	D14950	298
D14502	254	D14595	216	D14758	254	D14951	298
D14503	254	D14596	216	D14759	220	D14955	290
D14504	267	D14598	249	D14760	269	D14956	290
D14505	267	D14649	244	D14762	269	D14963	241
D14506	267	D14653	239	D14769	239	D14964	241
D14507	256	D14654	236	D14770	239	D14965	226
D14508	256	D14655	207	D14771	239	D14966	226
D14509	256	D14673	246	D14778	260	D14967	226
D14510	256	D14677	286	D14779	255	D14968	224
D14511	263	D14678	288	D14780	304	D14970	222
D14512	263	D14679	288	D14781	208	D14971	223
D14513	263	D14680	286	D14782	208	D14980	147
D14514	233, 263	D14681	288	D14802	296	D14983	147
D14515	263	D14682	288	D14803	279	D14984	147
D14517	181	D14683	288	D14804	279	D14985	179
D14518	177	D14684	288	D14805	278	D14989	270
D14523	177	D14685	285, 288	D14806	280	D14990	216
D14524	177	D14689	296	D14807	283	D14991	216
D14525	177	D14690	246	D14808	283	D14993	246
D14526	177	D14706	214	D14811	220	D14995	290
D14527	177	D14707	214	D14824	296	D23300	266
D14532	214	D14708	214	D14846	147	D23301	266
D14533	214	D14709	214	D14848	118	D23400	266
D14534	214	D14710	214	D14849	118	D23401	266
D14535	214	D14711	214	D14850	222	D23500	266
D14536	214	D14712	214	D14851	223	D23501	266
D14537	292	D14713	214	D14852	223	D23600	266
D14538	292	D14714	215	D14853	225	D23601	266
D14539	292	D14715	215	D14854	225	R12486	301
D14540	230	D14716	215	D14855	225	R12499	305
D14541	230	D14721	308	D14856	223	R12575	307
D14542	231	D14722	196	D14857	139, 147, 219	R12576	307
D14543	231	D14724	254	D14858	219	R12931	15
D14544	231	D14725	254	D14879	196	R12934	15
D14545	231	D14726	254	D14880	219	R14173	310
D14546	231	D14727	256	D14882	277	R14338	311
D14547	232	D14728	256	D14884	147	R14339	311
D14548	232	D14729	256	D14885	147	R14364	139, 180
D14549	233	D14730	256	D14900	285	R14407	305
D14550	233	D14731	256	D14901	285	R14412	311
D14551	233	D14732	257	D14902	285	R14413	301
D14552	232	D14733	257	D14903	284	R14416	311
D14553	232	D14734	257	D14904	284	R14418	310
D14554	232	D14735	257	D14905	279	R14426	310
D14555	220	D14736	257	D14906	277	SHD 8000 LED	228
D14556	220	D14737	258	D14915	281		
D14557	234	D14738	258	D14916	282		
D14558	234	D14739	258	D14922	270		
D14565	263	D14740	258	D14925	269		
D14566	263	D14741	258	D14926	269		
D14567	249	D14742	258	D14928	270		
D14568	249	D14743	235	D14929	270		
D14569	249	D14744	235	D14930	270		
D14574	295	D14745	235	D14931	270		
D14575	295	D14746	259	D14932	270		
D14576	297	D14747	254	D14933	270		
D14577	296	D14748	260	D14934	270		

# N° d'homologation - Numero di omologazione - Número de homologación



E2	253	MILI	175	E2	86710	FE87	194
E13	697	FRR	176	E2	86711	FE87	205
E13	698	FRR	176	E2	88017	LC7	166
E2	781	FE80	195	E2	88033	LC6	170
E9	1084	672	201	E2	88034	LC6	170
E2	1295	SMD00	198	E2	88035	LC7	167
E1	1559	BBS516	175	E2	88714	FE88	211
E2	2040	LC8	152	E2	88731	MILI	175
E13	2060	725	172	E2	90711	FE81	188
E2	2065	SMD98	203	E2	91098	LC4	171
E3	2617	2751	181	E2	91099	LC4	171
E4	4052	FRR	149	E2	91715	FE80	195
E2	4054	FPL93	200	E2	92057	FM91	59
E2	4088	FE98	192	E2	92058	FM91	59
E2	4089	FE98	192	E2	92059	FM91	59
E2	4090	FE94	203	E2	92060	FM91	59
E2	4091	FE94	203	E2	92061	FM91	59
E2	4092	FE94	198	E2	92062	FM91	59
E2	4093	FE98	198	E13	0001	R104	215
E2	4701	FE87	201	E13	0002	R104	215
E2	4703	FE87	188	E2	0050	C199	183
E2	5047	ICDL94	187	E11	010002	R70	214
E2	5052	FE95	193	E24	020078	FE12	211
E2	5126	FE95	205	E20	020889	DX	210
E9	6653	FRR	149	E2	04010	SMD98	191
E2	7001	EPP96	181	E2	04075	LC9	160
E2	7001	EPP98	181	E2	05010	FE04	190
E2	7102	FE02	193	E2	05011	FE04	202
E2	7139	ICDL94	187	E2	05021	SMD04	196
E11	7573	2963	220	E2	05022	SMD04	191
E2	8005	LC5	161	E2	05023	SMD04	202
E2	8040	SMD98	197	E2	06018	C105	183
E13	8434	725	172	E2	06024	LC5T	164
E2	9033	FE85	187	E2	07089	SH3	220
E2	9036	FE85	205	E2	07092	DXLC8	209
E2	9037	FE85	194	E2	08028	SRD07	185
E2	9056	LC7T	169	E2	09025	ICDL07	186
E2	10035	DX	210				
E2	10073	SRD08	185				
E2	10113	LC9 LED	142				
E13	10989	BX868	180				
E2	11017	EPP96LED	180				
E2	11128	ICDL10	186				
E9	11734	SLIM	148				
E2	12007	LC8	150				
E2	12056	C105	183				
E2	12164	LC10 LED	143				
E4	13992	FRR	149				
E2	14010	DX	207				
E2	14085	LC11	140				
E2	14086	LC11	140				
E2	16005	CTL15	144				
E2	16007	BL15	144				
E2	16027	LC12 LED	138				
E2	16059	ICDL15	186				
E2	16111	CTL14	148				
E2	18042	LC12G LED	138				
E2	19014	LPL18	179				
E2	19106	LCR19	146				
E2	19140	SL1000	219				
E2	20078	RL1500	219				
E4	23271	FRR	149				
E3	38553	2711	177				
E2	5108	MILI	175				
E13	51788	725	173				
E1	53329	BBS516	175				



## Index images - immagini - imágenes

### Feux arriere - Fanali posteriore - Pilotos traseros

p. 137-177

---



### Eclaireurs de plaque - Luci targa - Iluminación de placa

p. 178-181

---



### Feux clignotants - Luci intermittenti - Pilotos intermitentes

p. 182-188

---



### Feux de position - Luci di posizione - Pilotos de posición

p. 189-205

---



Feux de gabarits - Luci d'ingombro - Luces de anchura

p. 206-212



Signalisation passive - Segnaletica passiva - Señalización

p. 213-217

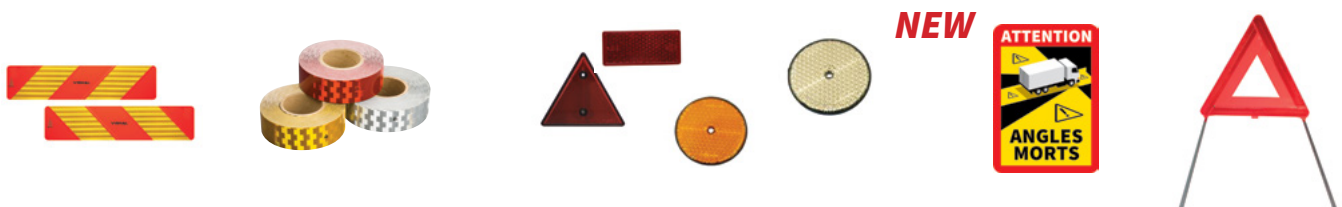

Phares de recul - Fari retromarcia - Faros marcha atrás

p. 218-220



Phares de travail - Fari da lavoro - Faros de trabajo

p. 221-237



## Index images - immagini - imágenes

Éclairage de sécurité - Luci di segnalazione - Faros de advertancia

p. 238-239

---



Phares de conduite - Proiettori - Faros delanteros

p. 240-244

---

**NEW**



Feux auxiliaires - Fari ausiliari - Iluminación auxiliar

p. 245-247

---



Éclairage intérieur - Illuminazione interna - Iluminación interior

p. 248-250

---



**NEW**



## Gyrophares - Girofari - Luces rotativas

p. 251-263

---



## Rampes lumineuses - Barre di segnalazione - Puentes luminosos

p. 264-267

---

**NEW**

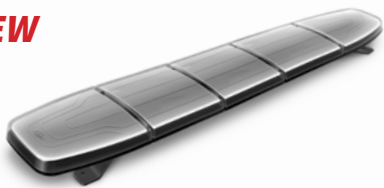

## Triflash

p. 268-270

---



## Feux de pénétration - Luci direzionali - Luces direccionales

p. 271-272

---



## Index images - immagini - imágenes

Alarmes sonores de recul - Cicalini retromarcia - Alarmas sonoras de marcha atrás  
p. 273-274

Standard



Multi-Frequency



Systemes caméras - Telecamere - Sistemas de cámara

p. 275-290



Coffres porte extincteur - Cassonetti porta estintore - Porta extintores  
p. 291-292



Produits électriques-électroniques - Prodotti elettrico-elettronici - Productos eléctrico-electrónicos  
p. 293-318



---

**MISE EN GARDE SUR LES RISQUES JURIDIQUES DE LA CONTREFAÇON**  
**AVVERTIMENTO SUI RISCHI LEGALI DELLA CONTRAFFAZIONE**  
**ADVERTENCIA SOBRE LOS RIESGOS JURIDICOS DE LA FALSIFICACION**

---

**MISE EN GARDE SUR LES RISQUES JURIDIQUES DE LA CONTREFAÇON DES PIÈCES D'ORIGINE**

Les **remplacements** ou **modifications** de composants autres que ceux montés et recommandés par le constructeur peuvent remettre en cause la sécurité des usagers de la route (diminution des performances photométriques).

Ex : **Le montage d'un cabochon adaptable sur un feu d'origine Vignal est interdit.**

Toute opération de ce type sur le matériel sera **à la charge entière de celui qui sera intervenu** et pourra **remettre en cause** l'homologation du véhicule délivrée par les autorités compétentes.

Le fabricant dégage sa responsabilité réglementaire.

**La contrefaçon et la concurrence déloyale de pièces sont condamnées par la loi civile et pénale :**

- La contrefaçon engage la responsabilité civile et pénale du fabricant, du revendeur, voire dans certains cas de l'utilisateur des pièces de contrefaçon.
- La concurrence déloyale engage la responsabilité civile du fabricant et du revendeur de copies serviles; en tirant de cette opération un avantage injustifié, **il fausse les règles normales de la concurrence** et réalise de ce fait **un acte de parasitisme** en détournant le travail de recherche et de conception, ainsi que le savoir-faire des constructeurs.

---

**AVVERTIMENTO SUI RISCHI LEGALI DELLA CONTRAFFAZIONE DEI PRODOTTI ORIGINALI**

La **sostituzione** o **modifica** di Ricambi con parti diverse da quelle assemblate e raccomandate dal costruttore può ridurre la sicurezza degli utenti della strada (riduzione delle performances fotometriche)

Es: **Il montaggio di una lente adattabile su un fanale originale Vignal è proibito.**

Qualunque operazione di questo tipo sul materiale **sarà giudicata come responsabilità di chi l'ha effettuata** e **comprometterà l'omologazione del veicolo** rilasciata dalle autorità competenti.

Il costruttore declina ogni responsabilità.

**La contraffazione e la concorrenza sleale di parti originali sono soggette legalmente a condanne civili e penali:**

- La contraffazione sottomette a responsabilità civile e penale il fabbricante, il rivenditore ed, in certi casi, l'utilizzatore di prodotti copiati.
- La concorrenza sleale sottomette a responsabilità civile il fabbricante e rivenditore di prodotti copiati; creando un vantaggio ingiustificato, **falsa le regole normali della concorrenza** e realizza un **atto di parasitismo** approfittando del lavoro di design, ricerca e sviluppo, così come del know-how dei fabbricanti di prodotti originali.

---

**ADVERTENCIA SOBRE LOS RIESGOS JURIDICOS DE LA FALSIFICACION DE LOS PRODUCTOS ORIGINALES**

Las **substituciones** o las **modificaciones** de Repuestos diferente que los montados y recomendados por el constructor pueden ser causa de una seguridad reducida de los usuarios de la carretera (disminución de los resultados fotométricos)

Ej: **El montaje de una tulipa adaptable sobre un piloto original Vignal está prohibido.**

Todas las operaciones de este tipo sobre el material **serán juzgadas como responsabilidad** del que habrá intervenido y **comprometerá la homologación del vehículo** emitida por las autoridades competentes.

El constructor declina todas las responsabilidades.

**La falsificación y la competencia desleal de piezas son condenadas por la ley civil y penal:**

- La falsificación está sujeta a responsabilidad civil y penal del fabricante, del revendedor, incluso, en ciertos casos, del utilizador de los productos copiados.
- La competencia desleal está sujeta a responsabilidad civil del fabricante y del revendedor de copias; trayendo una ventaja injustificada de esta operación, **falsea las reglas normales de la competencia** y realiza **un acto de parasitismo** aprovechándose del trabajo de I+D, así como del know-how de los constructores de productos originales.

---

## NORMES ET RÈGLEMENTATION

### NORME E RIGOLAMENTO

### NORMA Y REGLAMENTO

---

Les extraits de réglementation sont disponibles sur notre site web.

Les éléments sont extraits du règlement ECE R48 concernant la majorité des véhicules.  
Se référer au règlement pour des configurations particulières.

Les produits doivent être homologués selon le dernier amendement en vigueur.  
L'utilisateur est responsable de la conformité de l'équipement de son véhicule.

VIGNAL s'engage sur la conformité de ses produits.



Le sigle ADR signifie que le produit est homologué pour le montage sur des véhicules qui satisfont aux dispositions ADR (accord européen relatif au transport international des marchandises dangereuses par route).

Les produits ADR ont un indice de protection d'au moins IP54.

L'indice de protection IP détermine le degré de protection du matériel contre la pénétration des corps solides (1er chiffre) et des liquides (2ème chiffre).



Exemple : IP54

1er chiffre : 5 => Protégé contre les infiltrations de poussière

2ème chiffre : 4 => Protégé contre les projections d'eau (haute pression) de toutes les directions

---

I estratti di regolamento sono disponibili sul nostro sito web.

I elementi sono estratti del regolamento ECE R48 per la maggior parte dei veicoli.  
Riferirsi al regolamento per configurazione speciale.

I prodotti devono essere omologati secondo l'ultima revisione in vigore.  
L'utilizzatore è responsabile della conformità dell'attrezzatura del suo veicolo.

VIGNAL si impegna sulla conformità dei suoi prodotti.



Il siglo ADR significa che il prodotto è omologato per il montaggio sui veicoli omologati ADR (accordo europeo sul trasporto internazionale delle merci pericolose).

I prodotti ADR hanno un indice di protezione minimo IP54.

L'indice di protezione IP determina il grado di protezione contro l'ingresso di materie solide (primo numero) e liquide (secondo numero).



Esempio : IP54

Primo numero: 5 = proteggeto contra la polvere

Secondo numero: 4 = proteggeto contra l'acqua (alta pressione) da qualche direzione.

---

Los extractos de reglamento están disponibles en nuestro sitio web.

Los elementos son extractos del reglamento ECE R48 que concierne la mayoría de los vehículos.  
Referirse al reglamento para configuraciones particulares.

Los productos tienen que ser homologados según la última enmienda en vigor.  
El usuario es responsable de la conformidad del equipo de su vehículo.

VIGNAL se compromete sobre la conformidad de sus productos.



El sigla ADR significa que el producto es homologado para el montaje sobre vehículos homologados ADR (Acuerdo Europeo sobre el transporte internacional de cargas peligrosas por vía terrestre).

Los productos ADR tienen un grado de protección de al menos IP54.

El IP determina el grado de protección del material contra el ingreso de objetos sólidos (primer dígito) e agua (segundo dígito).



Ejemplo : IP54

1er dígito : 5 => Protección contra polvo

2do : 4 => Protección contra chorros de agua

**NORMES ET RÈGLEMENTATION**  
**NORME E RIGOLAMENTO**  
**NORMA Y REGLAMENTO**

**Indice de protection**

Indice	1 <sup>er</sup> chiffre (dizaine) = Protection contre la poussière	2 <sup>ème</sup> chiffre (unité) = Protection contre l'eau
0	Aucune protection.	Aucune protection.
1	Protégé contre les corps solides supérieurs à 50 mm.	Protégé contre les chutes verticales de gouttes d'eau.
2	Protégé contre les corps solides supérieurs à 12,5 mm.	Protégé contre les chutes de gouttes d'eau jusqu'à 15° de la verticale.
3	Protégé contre les corps solides supérieurs à 2,5 mm.	Protégé contre l'eau en pluie jusqu'à 60° de la verticale.
4	Protégé contre les corps solides supérieurs à 1 mm.	Protégé contre les projections d'eau de toutes directions.
5	Protégé contre les poussières.	Protégé contre les jets d'eau de toutes directions à la lance.
6	Totalement protégé contre les poussières.	Protégé contre les forts jets d'eau de toutes directions à la lance.
7	-	Protégé contre les effets de l'immersion (jusqu'à 1m).
8	-	Matériel submersible dans des conditions spécifiées (immersion prolongée) au delà de 1 m et pendant 30 minutes.
9K	-	Protection contre le nettoyage à haute pression.

**International Protection**

Livello	1 <sup>a</sup> cifra = Protezione contro l'accesso di corpi solidi	2 <sup>nd</sup> digit = Protezione contro l'accesso di liquidi
0	Nessuna protezione.	Non protetto.
1	Protetto contro corpi solidi di dimensioni superiori a 50mm.	Protetto da caduta verticale di gocce d'acqua.
2	Protetto contro corpi solidi di dimensioni superiori a 12mm.	Protetto da caduta di gocce d'acqua con inclinazione massima 15°.
3	Protetto contro corpi solidi di dimensioni superiori a 2.5mm.	Protetto dalla pioggia.
4	Protetto contro corpi solidi di dimensioni superiori a 1mm.	Protetto da spruzzi.
5	Protetto contro la polvere.	Protetto da getti d'acqua.
6	Totalmente protetto contro la polvere.	Protetto da ondate.
7	-	Protetto da immersione temporanea.
8	-	Protetto da immersione continua.
9K	-	Protetto da alta pressione

**Grado de protección IP**

Nivel	Primer dígito = Protección contra el ingreso de objetos sólidos	Segundo dígito = Protección contra el ingreso de agua
0	Sin protección.	Sin protección.
1	Protección contra los objetos sólidos mayores de 50 mm.	Protección contra goteos de agua.
2	Protección contra los objetos sólidos mayores de 12,5 mm.	Protección contra goteos de agua (inclinado 15°).
3	Protección contra los objetos sólidos mayores de 2,5 mm.	Protección contra agua nebulizada (spray).
4	Protección contra los objetos sólidos mayores de 1,0 mm.	Protección contra proyecciones de agua de toda dirección.
5	Protección contra polvo.	Protección contra chorros de agua.
6	Protección fuerte contra polvo.	Protección contra fuertes chorros de agua.
7	-	Inmersión completa en agua.
8	-	Inmersión completa y continua en agua.
9K	-	Protección contra la limpieza de alta presión.







# VIGNAL

## 2021



**NBB**

**ABL**

**VIGNAL**

**CEA**

**SACEX**

### VIGNAL GROUP

19, avenue du 24 Août 1944  
69960 Corbas  
FRANCE

E-mail : [contact@vignal-group.com](mailto:contact@vignal-group.com)  
Site web : [www.vignal-group.com](http://www.vignal-group.com)

**VIGNAL SYSTEMS**  
19, avenue du 24 Août 1944  
69960 Corbas  
FRANCE

**VIGNAL ABL**  
3, rue de la Cotonnière  
Z.I. du Chemin Vert  
14000 Caen  
FRANCE

**VIGNAL C.E.A.**  
11, Via Alla Rossa  
6862 Rancate  
SWITZERLAND

**VIGNAL CHANGZHOU**  
Building B2, N° 585  
Huanghe West Road  
Xinbei District  
Changzhou City, Jiangsu Province  
CHINA

**VIGNAL ABL USA**  
660 Golf Club Blvd  
Mosinee, WI 54455  
USA



Ref: 99999CA



[www.vignal-group.com](http://www.vignal-group.com)